



**COUNCIL OF  
THE EUROPEAN UNION**

**Brussels, 6 August 2012**

**13092/12**

**ENT 196  
ENV 665  
MI 525**

**COVER NOTE**

---

from:	European Commission
date of receipt:	25 July 2012
to:	General Secretariat of the Council of the European Union
No Cion doc.:	D016964/03
Subject:	<b>COMMISSION REGULATION (EU) No .../..of XXX</b> implementing Regulation (EC) No 661/2009 of the European Parliament and of the Council with regard to type-approval requirements for masses and dimensions of motor vehicles and their trailers and amending Directive 2007/46/EC of the European Parliament and of the Council

---

Delegations will find attached Commission document D016964/03.

Encl.: D016964/03



EUROPEAN COMMISSION

Brussels, **XXX**  
D016964/03  
[...] (2012) **XXX** draft

**COMMISSION REGULATION (EU) No .../..**

**of **XXX****

**implementing Regulation (EC) No 661/2009 of the European Parliament and of the Council with regard to type-approval requirements for masses and dimensions of motor vehicles and their trailers and amending Directive 2007/46/EC of the European Parliament and of the Council**

COMMISSION REGULATION (EU) No .../..

of **XXX**

**implementing Regulation (EC) No 661/2009 of the European Parliament and of the Council with regard to type-approval requirements for masses and dimensions of motor vehicles and their trailers and amending Directive 2007/46/EC of the European Parliament and of the Council**

THE EUROPEAN COMMISSION,

Having regard to the Treaty on the Functioning of the European Union,

Having regard to Regulation (EC) No 661/2009 of the European Parliament and of the Council concerning type-approval requirements for the general safety of motor vehicles, their trailers and systems, components and separate technical units intended therefor<sup>1</sup>, and in particular Article 14(1)(a) thereof,

Having regard to Directive 2007/46/EC of the European Parliament and of the Council establishing a framework for the approval of motor vehicles and their trailers, and of systems, components and separate technical units intended for such vehicles (Framework Directive)<sup>2</sup>, and in particular Article 39(2), (3) and (5) thereof,

Whereas:

- (1) Regulation (EC) No 661/2009 is a separate Regulation for the purposes of type-approval provided for in Directive 2007/46/EC.
- (2) Regulation (EC) No 661/2009 repeals Council Directive 92/21/EEC of 31 March 1992 on the masses and dimensions of motor vehicles of category M<sub>1</sub><sup>3</sup> as well as Directive 97/27/EC of the European Parliament and of the Council of 22 July 1997 relating to the masses and dimensions of certain categories of motor vehicles and their trailers and amending Directive 70/156/EEC<sup>4</sup>. The requirements relating to the masses and dimensions of motor vehicles and their trailers set out in those Directives should be carried over to this Regulation and where necessary, amended in order to adapt them to the development of technical and scientific knowledge.
- (3) Regulation (EC) No 661/2009 lays down fundamental provisions on requirements for the type-approval of motor vehicles and their trailers with regard to their masses and dimensions. Therefore, it is necessary to also set out the specific procedures, tests and requirements for such type-approval.

---

<sup>1</sup> OJ L 200, 31.07.2009, p. 1.

<sup>2</sup> OJ L 263, 9.10.2007, p. 1.

<sup>3</sup> OJ L 129, 14.5.1992, p. 1.

<sup>4</sup> OJ L 233, 25.8.1997, p. 1.

- (4) Council Directive 96/53/EC of 25 July 1996 laying down for certain road vehicles circulating within the Community the maximum authorised dimensions in national and international traffic and the maximum authorised weights in international traffic<sup>5</sup> lays down certain maximum authorised dimensions for both national and international traffic in the Member States. It is therefore important to take into account, for the purposes of the construction of vehicles, the dimensions which have already been harmonised in the Union in order to foster and ensure the free circulation of goods.
- (5) Directive 97/27/EC allowed Member States to grant EC type-approval for vehicles the outermost dimensions of which did not match the maximum authorised dimensions provided for in that Directive. It also allowed Member States to refuse registration of vehicles that had been granted EC type-approval when their outermost dimensions did not meet the requirements of their national law. It is important to maintain the possibility to allow under certain conditions the type-approval of vehicles which exceed the authorised limits where this proves to be advantageous for road traffic and for the environment in the Member States where the road infrastructure is adapted to that situation. Therefore, the possibility to approve such vehicles under small series type-approval or individual approval schemes should be ensured, provided that the quantity of vehicles that may benefit from a derogation pursuant to Article 23 of Directive 2007/46/EC as regards the maximum authorised dimensions is limited to what is necessary for the purposes of this Regulation. Annex XII to Directive 2007/46/EC should therefore be amended to include such quantitative limits.
- (6) Directive 96/53/EC lays down maximum authorised masses that are applicable only to international traffic. However, that Directive allows the Member States to continue to apply their national legislation for national traffic. As a consequence, the harmonisation of the technically permissible maximum laden mass and the technically permissible maximum mass on the axles or on a group of axles for the purposes of circulation in the Member States does not appear to be feasible in the short term. Nevertheless, due to the existence of non-harmonised rules on the construction of the road infrastructure, it is appropriate to require Member States to determine the registration/in service maximum permissible masses of vehicles that are permitted for national traffic or for international traffic under Directive 96/53/EC and to establish a procedure for such determination.
- (7) Given the experience gained in the application of Union legislation concerning masses and dimensions of vehicles, it is necessary to provide for clearly defined concepts. Some of those concepts have already been defined in Directives 97/27/EC and 92/21/EEC. For reasons of consistency, it is appropriate to take over those definitions and, where necessary, to adapt them in the light of technical and scientific knowledge.
- (8) Given that the definition of the actual mass of an individual vehicle has been included in this Regulation, it is necessary, in order to avoid confusion in filling in the certificate of conformity, to amend Annex IX to Directive 2007/46/EC accordingly.
- (9) Since the White Paper “Roadmap to a Single European Transport Area – Towards a competitive and resource efficient transport system<sup>6</sup>” has underlined the need to

---

<sup>5</sup> OJ L 235, 17.9.1996, p. 59

<sup>6</sup> (COM(2011)144)

improve the aerodynamic performance of road vehicles and research has shown that fuel consumption of motor vehicles and therefore CO<sub>2</sub> emissions could be significantly reduced by fitting aerodynamic devices to vehicles, it is important to allow the fitting of such aerodynamic devices to vehicles. Given that aerodynamic devices consist in adds-on that, due to their design, protrude beyond the outermost part of the vehicles at the back or laterally, they should be included in the list of devices or equipment that are not taken into account for the determination of the outermost dimensions. However, it is essential to limit their protrusion at the back and laterally so that road safety is not impaired and inter-modality transport remains possible. The necessary technical requirements should therefore be set out in this Regulation.

- (10) Available software makes possible the use of virtual testing methods based on computer-aided techniques. Given that those techniques allow for more cost-efficient and less burdensome testing, it is appropriate to provide for the possibility to use them for checking whether a vehicle is able to manoeuvre in a complete trajectory of 360° and for measuring the maximum rear swing-out when the vehicle is manoeuvring inside the trajectory. It is therefore also necessary to add this Regulation to the list of regulatory acts included in Annex XVI to Directive 2007/46/EC.
- (11) With a view to ensuring the proper operation of the type-approval system, it is appropriate to update the Annexes to Directive 2007/46/EC.
- (12) Annexes I, III, IX, XII and XVI to Directive 2007/46/EC should therefore be amended accordingly. Since the provisions of Annex XII are sufficiently detailed and need no further transposition by Member States, it is therefore appropriate to replace it by means of a Regulation in accordance with Article 39(8) of Directive 2007/46/EC.
- (13) The measures provided for in this Regulation are in accordance with the opinion of the Technical Committee - Motor Vehicles,

HAS ADOPTED THIS REGULATION:

#### *Article 1*

##### ***Subject matter and scope***

1. This Regulation lays down the requirements for the EC type-approval of motor vehicles and their trailers with regard to their masses and dimensions.
2. This Regulation applies to incomplete, complete and completed vehicles of categories M, N and O.

#### *Article 2*

##### ***Definitions***

For the purposes of this Regulation, the following definitions shall apply in addition to the definitions set out in Directive 2007/46/EC and Regulation (EC) No 661/2009:

- (1) 'vehicle type' means a set of vehicles as defined in Part B of Annex II to Directive 2007/46/EC;
- (2) 'standard equipment' means the basic configuration of a vehicle which is equipped with all the features that are required under the regulatory acts referred to in Annex IV and Annex XI to Directive 2007/46/EC, including all features that are fitted without giving rise to any further specifications on configuration or equipment level;
- (3) 'optional equipment' means all the features not included in the standard equipment which are fitted to a vehicle under the responsibility of the manufacturer that can be ordered by the customer;
- (4) 'mass in running order' means
  - (a) in the case of a motor vehicle:

the mass of the vehicle, with its fuel tank(s) filled to at least 90 % of its or their capacity/ies, including the mass of the driver, of the fuel and liquids, fitted with the standard equipment in accordance with the manufacturer's specifications and, when they are fitted, the mass of the bodywork, the cabin, the coupling and the spare wheel(s) as well as the tools;
  - (b) in the case of a trailer:

the mass of the vehicle including the fuel and liquids, fitted with the standard equipment in accordance with the manufacturer's specifications, and, when they are fitted, the mass of the bodywork, additional coupling(s), the spare wheel(s) and the tools;
- (5) 'mass of the optional equipment' means the mass of the equipment which may be fitted to the vehicle in addition to the standard equipment, in accordance with the manufacturer's specifications;
- (6) 'actual mass of the vehicle' means the mass in running order plus the mass of the optional equipment fitted to an individual vehicle;
- (7) 'technically permissible maximum laden mass' (M) means the maximum mass allocated to a vehicle on the basis of its construction features and its design performances; the technically permissible laden mass of a trailer or of a semi-trailer includes the static mass transferred to the towing vehicle when coupled;
- (8) 'technically permissible maximum laden mass of the combination' (MC) means the maximum mass allocated to the combination of a motor vehicle and one or more trailers on the basis of its construction features and its design performances or the maximum mass allocated to the combination of a tractor unit and a semi-trailer;
- (9) 'technically permissible maximum towable mass' (TM) means the maximum mass of one or more trailers that may be towed by a towing vehicle which corresponds to the total load transmitted to the ground by the wheels of an axle or a group of axles on any trailer coupled to the towing vehicle;

- (10) *'axle'* means the common axis of rotation of two or more wheels whether power-driven or freely rotating, and whether in one or more segments located in the same plane perpendicular to the longitudinal centre-line of the vehicle;
- (11) *'group of axles'* means a number of axles having an axle spacing that is restricted to one of the axle spacings referred to as distance 'd' in Annex I to Directive 96/53/EC and which interact due to the specific design of the suspension;
- (12) *'solo axle'* means an axle that cannot be considered as part of a group of axles;
- (13) *'technically permissible maximum mass on the axle' (m)* means the mass corresponding to the maximum permissible static vertical load transmitted to the ground by the wheels of the axle, on the basis of the construction features of the axle and of the vehicle and their design performances;
- (14) *'technically permissible maximum mass on a group of axles' ( $\mu$ )* means the mass corresponding to the maximum permissible static vertical load transmitted to the ground by the wheels of the group of axles, on the basis of the construction features of the group of axles and of the vehicle and their design performances;
- (15) *'coupling'* means a mechanical device including component items as defined in points 2.1 to 2.6 of Regulation No 55 of the United Nations Economic Commission for Europe (UNECE) — Uniform provisions concerning the approval of mechanical coupling components of combinations of vehicles <sup>7</sup> and a close-coupling device as defined in point 2.1.1 of UNECE Regulation No 102 — Uniform provisions concerning the approval of I.A close-coupling device (CCD) II. Vehicles with regard to the fitting of an approved type of CCD <sup>8</sup>;
- (16) *'coupling point'* means the centre of engagement of the coupling fitted to a towed vehicle within the coupling fitted to a towing vehicle;
- (17) *'mass of the coupling'* means the mass of the coupling itself and of the parts necessary for the attachment of the coupling to the vehicle;
- (18) *'technically permissible maximum mass at the coupling point'* means:
- (a) in the case of a towing vehicle, the mass, corresponding to the maximum permissible static vertical load on the coupling point ('S' or 'U' value) of a towing vehicle, on the basis of the construction features of the coupling and of the towing vehicle;
  - (b) in the case of a semi-trailer, a centre-axle trailer or a rigid drawbar trailer, the mass corresponding to the maximum permissible static vertical load ('S' or 'U' value) to be transferred by the trailer to the towing vehicle at the coupling point, on the basis of the construction features of the coupling and of the trailer;

---

<sup>7</sup> OJ L 227, 28.8.2010, p. 1.

<sup>8</sup> OJ L 351, 20.12.2008, p.44.

- (19) *'mass of the passengers'* means a rated mass depending on the vehicle category multiplied by the number of seating positions including, if any, the seating positions for crew members and the number of standees, but not including the driver;
- (20) *'mass of the driver'* means a mass rated at 75 kg located at the driver's seating reference point;
- (21) *'pay-mass'* means the difference between the technically permissible maximum laden mass and the mass in running order increased by the mass of the passengers and the mass of the optional equipment;
- (22) *'length'* means the dimension defined in points 6.1.1, 6.1.2 and 6.1.3 of Standard ISO 612:1978; this definition also applies also to articulated vehicles made up of two or more sections;
- (23) *'width'* means the dimension defined in point 6.2 of Standard ISO 612:1978;
- (24) *'height'* means the dimension defined in point 6.3 of Standard ISO 612:1978;
- (25) *'wheelbase'* means the following:
- (a) the dimension referred to in point 6.4.1 of Standard ISO 612:1978;
  - (b) for a centre-axle trailer with one axle, the horizontal distance between the vertical axis of the coupling and the centre of the axle;
  - (c) for a centre-axle trailer with more than one axle, the horizontal distance between the vertical axis of the coupling and the centre of the first axle;
- (26) *'axle spacing'* means the distance between two consecutive axles referred to in point 6.4 of Standard ISO 612:1978 in the case of vehicles with more than two axles; where the vehicle is fitted with two axles only, or in the case of a semi-trailer, a drawbar trailer or a rigid drawbar trailer, the axle spacing referred to in point 6.4.2 of Standard ISO 612:1978 has the meaning of 'wheelbase' as defined in point (25);
- (27) *'track'* means the distance referred to in point 6.5 of Standard ISO 612:1978;
- (28) *'fifth wheel lead'* means the distance referred to in point 6.19.2 of Standard ISO 612: 1978, taking into account the note referred to in point 6.19 of the same standard;
- (29) *'front fitting radius of semi-trailer'* means the horizontal distance from the axis of the kingpin to any point at the front of the semi-trailer;
- (30) *'front overhang'* means the horizontal distance between the vertical plane passing through the first axle or the kingpin axle in the case of a semi-trailer and the foremost point of the vehicle;
- (31) *'rear overhang'* means the horizontal distance between the vertical plane passing through the last rear axle and the rearmost point of the vehicle; where the vehicle is fitted with a coupling that is not removable, the rearmost point of the vehicle is the coupling point;



- (32) *'length of the loading area'* means the distance from the foremost internal point to the rearmost internal point of the cargo area, measured horizontally in the longitudinal plane of the vehicle;
- (33) *'rear swing-out'* means the distance between the actual extreme point reached by the rear end of a vehicle when manoeuvring in the conditions specified in Section 7 of Part B or in Section 6 of Part C of Annex I to this Regulation;
- (34) *'axle-lift device'* means a mechanism fitted to a vehicle for the purpose of raising the axle clear off the ground and lowering it to the ground;
- (35) *'lift axle or retractable axle'* means an axle which can be raised from its normal position and re-lowered by an axle-lift device;
- (36) *'loadable axle'* means an axle the load on which can be varied without the axle being raised by the use of an axle-lift device;
- (37) *'air suspension'* means a suspension system on which at least 75 % of the spring effect is caused by the air spring;
- (38) *'class of a bus or of a coach'* means a set of vehicles as defined in points 2.1.1 and 2.1.2 of UNECE Regulation No 107 – Uniform provisions concerning the approval of category M<sub>2</sub> or M<sub>3</sub> vehicles with regard to their general construction<sup>9</sup>;
- (39) *'articulated vehicle'* means a vehicle of category M<sub>2</sub> or M<sub>3</sub> as defined in point 2.1.3. of UNECE Regulation No 107;
- (40) *'indivisible load'* means a load that cannot, for the purposes of carriage by road, be divided into two or more loads without undue expense or risk of damage and which, owing to its mass or dimension, cannot be carried by a vehicle the masses and dimensions of which comply with the maximum authorised masses and dimensions applicable in a Member State.

### *Article 3*

#### ***Obligations of manufacturers***

1. The manufacturer shall determine, for each version within a vehicle type, irrespective of the state of completion of the vehicle, the following masses:
  - (a) the technically permissible maximum laden mass;
  - (b) the technically permissible maximum laden mass of the combination;
  - (c) the technically permissible maximum towable mass;
  - (d) the technically permissible maximum mass on the axles or the technically permissible maximum mass on a group of axles;

---

<sup>9</sup> OJ L 53, 29.09.2010, p. 1.

- (e) the technically permissible maximum masses at the coupling point(s) taking into account the technical features of the couplings that are fitted or can be fitted to the vehicle as the case may be.
2. When determining the masses referred to in paragraph 1, the manufacturer shall take into account the best practices of good engineering and the best available technical knowledge in order to minimise the risks of mechanical failure, in particular those due to fatigue of materials, and to avoid damage to the road infrastructure.
  3. When determining the masses referred to in paragraph 1, the manufacturer shall take into account the maximum speed by construction of the vehicle.

Where the vehicle is equipped by the manufacturer with a speed limitation device, the maximum speed by construction shall be the true speed permitted by the speed limitation device.

4. When determining the masses referred to in paragraph 1, the manufacturer shall not impose restrictions on the use of the vehicle except those concerning the tyre capacities that can be adjusted to the speed by construction as is allowed under UNECE Regulation No 54 — Uniform provisions concerning the approval of pneumatic tyres for commercial vehicles and their trailers<sup>10</sup> and in Section 5 of Annex II to Commission Regulation (EU) 458/2011<sup>11</sup>.
5. For incomplete vehicles, including chassis-cabin vehicles, that require a further stage of completion, the manufacturer shall provide all relevant information to the next stage manufacturers so that the requirements of this Regulation continues to be fulfilled.

For the purposes of the first subparagraph, the manufacturer shall specify the position of the centre of gravity of the mass corresponding to the sum of the load.

6. Incomplete vehicles of categories M<sub>2</sub>, M<sub>3</sub>, N<sub>2</sub> and N<sub>3</sub> not fitted with a bodywork shall be designed so as to allow the subsequent stage manufacturers to be able to fulfil the requirements of Sections 7 and 8 of Part B and Section 6 and 7 of Part C of Annex I.

#### *Article 4*

##### ***Provisions for EC type-approval of a type of vehicle with regard to its masses and dimensions***

1. The manufacturer or his representative shall submit to the type-approval authority the application for EC type-approval of a type of vehicle as regard its masses and dimensions.
2. The application shall be drawn up in accordance with the model information document set out in Part A of Annex V.

---

<sup>10</sup> OJ L 183, 11.7.2008, p.41.

<sup>11</sup> OJ L 124, 13.5.2011, p.11.

3. For the purposes of mass distribution calculations, the manufacturer shall provide the type-approval authority, for each technical configuration within the vehicle type as determined by the set of values of the relevant points in Annex V, with the information necessary to identify the following masses:
  - (a) the technically permissible maximum laden mass;
  - (b) the technically permissible maximum mass on the axles or group of axles;
  - (c) the technically permissible maximum towable mass;
  - (d) the technically permissible maximum mass at the coupling point(s);
  - (e) the technically permissible maximum laden mass of the combination.

The information shall be provided in tabular or any other appropriate format, in agreement with the type-approval authority.

4. Where the optional equipment significantly affects the masses and dimensions of the vehicle, the manufacturer shall provide the technical service with the location, mass and geometrical position of the gravity centre with respect to the axles of the optional equipment that can be fitted to the vehicle.
5. By way of derogation from paragraph 4, where the optional equipment is made up of several parts located in various spaces in the vehicle, the manufacturer may provide the technical service with the distribution of the mass of the optional equipment on the axles only.
6. For groups of axles, the manufacturer shall indicate the load distribution among the axles of the total mass applied to the group.

Where necessary, the manufacturer shall state the distribution formulae or produce the relevant distribution graphs.
7. Where the approval authority or the technical service deems it necessary, they may request the manufacturer to make available a vehicle representative of the type to be approved for the purposes of inspection.
8. The vehicle manufacturer may submit an application for recognition of the equivalence of a suspension to air suspension to the type-approval authority.

The type-approval authority shall recognise the equivalence of a suspension to air suspension where the requirements of Annex III are fulfilled.

Where the technical service has recognised the equivalence, it shall issue a test report. The type-approval authority shall attach the test report and a technical description of the suspension to the EC type-approval certificate.

9. Where the requirements set out in Annexes I to IV, of this Regulation are met, the approval authority shall grant a type-approval in accordance with the numbering system set out in Annex VII to Directive 2007/46/EC.

A Member State shall not assign the same number to another vehicle type.

10. For the purposes of paragraph 9, the type-approval authority shall deliver an EC type-approval certificate established in accordance with the model set out in Part B of Annex V.
11. The permissible deviations referred to in Appendix 2 to Annex I shall apply for the purposes of Article 12(2) of Directive 2007/46/EC

#### *Article 5*

##### ***Registration/in-service maximum permissible masses***

1. For the purposes of registration and entry into service of vehicles type-approved under this Regulation, national authorities shall determine, for each variant and version within the type of vehicle, all of the following masses that are permitted for national traffic or for international traffic under Directive 96/53/EC:
  - (a) the registration/in-service maximum permissible laden mass;
  - (b) the registration/in-service maximum permissible mass on the axle(s);
  - (c) the registration/in-service maximum permissible mass on the group of axles;
  - (d) the registration/in-service maximum permissible towable mass;
  - (e) the registration/in-service maximum permissible laden mass of the combination.

National authorities shall establish the procedure for the determination of the registration/in service maximum permissible masses referred to in the first subparagraph. They shall designate the competent authority entrusted with the determination of those masses, and shall specify the information that must be provided to that competent authority.

2. The registration/in-service maximum permissible masses determined in accordance with the procedure referred to in paragraph 1 may not exceed the maximum masses referred to in Article 3(1).
3. The manufacturer shall be consulted by the competent authority as regards the mass distribution on the axles or group of axles in order to ensure the proper functioning of the systems of the vehicle, in particular the brake- and steering system.
4. When determining the registration/in-service maximum permissible masses, national authorities shall ensure that the requirements of the regulatory acts listed in Annex IV and Annex XI to Directive 2007/46/EC continue to be fulfilled.
5. Where national authorities concludes that the requirements of one of the regulatory acts listed in Annex IV and Annex XI to Directive 2007/46/EC, with the exception of this Regulation, are no longer fulfilled, they shall require that fresh tests are conducted and a new type-approval or an extension as the case may be, be granted by

the type-approval authority that has granted the initial type-approval under the regulatory act in question.

#### *Article 6*

##### ***Derogations***

1. Without prejudice to Article 4(3) of Directive 96/53/EC, an EC type-approval may be granted for vehicles the dimensions of which exceed the requirements of this Regulation that are intended for the transport of indivisible loads. In such a case, the type-approval certificate and the certificate of conformity shall clearly indicate that the vehicle is intended for the transport of indivisible loads only.
2. Member States may grant approvals under Articles 23 and 24 of Directive 2007/46/EC for vehicles exceeding the maximum authorised dimensions set out in point 1.1. of Parts B, C and D of Annex I to this Regulation.

Type-approvals under Article 23 of Directive 2007/46/EC shall be subject to the quantitative limits set out in Section 3 of Part A of Annex XII to that Directive.

#### *Article 7*

##### ***Transitional provisions***

1. National authorities shall permit the sale and entry into service of vehicles type-approved before the date referred to in Article 13(2) of Regulation (EC) No 661/2009 and shall continue to grant extensions to approvals granted under the terms of Directive 92/21/EEC and Directive 97/27/EC.
2. By way of derogation from paragraph 1, EC type-approvals granted pursuant to Article 7 of Directive 97/27/EC shall cease to be valid on the date referred to in Article 19(1) of Regulation (EC) No 661/2009.

However, Member States may register and permit the sale or entry into service of end-of-series vehicles whose EC type-approval is no longer valid where the manufacturer so requests, in accordance with Article 27 of Directive 2007/46/EC.

3. As from [*.....12 months from the date of entry into force of this Regulation - to be filled in by OPOCE*] manufacturers shall deliver certificates of conformity which are in accordance with this Regulation.

Until [*.....12 months minus one day from the date of entry into force of this Regulation - to be filled in by OPOCE*] they shall indicate the actual mass of the vehicle in entry 52 of the certificate of conformity, unless it is indicated in one of the other entries of the certificate of conformity.

*Article 8*

***Amendments to Directive 2007/46/EC***

Annexes I, III, IX, and XVI to Directive 2007/46/EC are amended in accordance with Annex VI to this Regulation.

Annex XII to Directive 2007/46/EC is replaced by Annex VII to this Regulation.

*Article 9*

***Entry into force***

This Regulation shall enter into force on the twentieth day following that of its publication in the *Official Journal of the European Union*.

It shall apply to new vehicle types for which type-approval is granted from 1 November 2012.

This Regulation shall be binding in its entirety and directly applicable in all Member States.

Done at Brussels,

*For the Commission*  
*The President*  
*José Manuel Barroso*

## LIST OF ANNEXES

- Annex I     PART A: Technical requirements for vehicles of category M<sub>1</sub> and N<sub>1</sub>.  
PART B: Technical requirements for vehicles of category M<sub>2</sub> and M<sub>3</sub>.  
PART C: Technical requirements for vehicles of category N<sub>2</sub> and N<sub>3</sub>.  
PART D: Technical requirements for vehicles of category O.
- Appendix 1     List of devices and equipment that are not required to be taken into account for the determination of the outermost dimensions.
- Appendix 2     Permissible deviations for type-approval and conformity of production.
- Appendix 3     Figures regarding manoeuvrability.
- Annex II     Gradeability of off-road vehicles.
- Annex III     Conditions of equivalence of a suspension to air-suspension.
- Annex IV     Technical requirements for the installation of lift- or loadable axles on vehicles.
- Annex V     PART A: Information document.  
PART B: EC type-approval certificate.
- Annex VI     Amendments to Annexes I, III, IX, and XVI to Directive 2007/46/EC.
- Annex VII     Annex XII to Directive 2007/46/EC.

## ANNEX I

### Technical requirements

#### PART A

##### **Vehicles of category M<sub>1</sub> and N<sub>1</sub>**

#### **1. Maximum authorised dimensions**

1.1. The dimensions shall not exceed the following values:

1.1.1. Length: 12.00 m.

1.1.2. Width:

(a) M<sub>1</sub>: 2.55 m;

(b) N<sub>1</sub>: 2.55 m;

(c) N<sub>1</sub>: 2.60 m for vehicles fitted with a bodywork with insulated walls of at least 45 mm thick, as referred to in Appendix 2 of Part C of Annex II to Directive 2007/46/EC;

1.1.3. Height: 4.00 m.

1.2. For the purposes of measurement of the length, width and height, the vehicle shall be at its mass in running order, placed on a horizontal and flat surface with tyres inflated at the pressure recommended by the manufacturer.

1.3. Only the devices and equipment referred to in Appendix 1 of this Annex shall not be taken into account for the determination of the length, width and height.

#### **2. Mass distribution**

2.1. The sum of the technically permissible maximum mass on the axles shall not be less than the technically permissible maximum laden mass of the vehicle.

2.2. The technically permissible maximum laden mass of the vehicle shall not be less than the mass of the vehicle in running order plus the mass of the passengers plus the mass of the optional equipment plus the mass of the coupling if not included in the mass in running order.

2.3. Where the vehicle is laden to the technically permissible maximum laden mass, the mass on each axle shall not exceed the technically permissible maximum mass on that axle.

2.4. Where the vehicle is laden to the technically permissible maximum laden mass, the mass on the front axle shall in no event be less than 30 % of the technically permissible maximum laden mass of the vehicle.



- 2.4.1. Where the vehicle is laden to the technically permissible maximum laden mass plus the technically permissible maximum mass at the coupling point, the mass on the front axle shall in no event be less than 20 % of the technically permissible maximum laden mass of the vehicle.
- 2.5. Where a vehicle is equipped with removable seats, the verification procedure shall be limited to the condition with the maximum number of seating positions.
- 2.6. For the purposes of verifying the requirements laid down in points 2.2, 2.3 and 2.4:
  - (a) The seats shall be adjusted as prescribed in point 2.6.1
  - (b) the masses of the passengers, the pay-mass and the mass of the optional equipment shall be distributed as prescribed in points 2.6.2. to 2.6.4.2.3.
- 2.6.1. Seat adjustment
  - 2.6.1.1. The seats where adjustable shall be moved to their rearmost position.
  - 2.6.1.2. Where there are other possibilities for adjusting the seat (vertical, angled, seat back, etc.) the adjusted positions shall be as specified by the vehicle manufacturer.
  - 2.6.1.3. In the case of suspension seats, the seat shall be locked in the position specified by the manufacturer.
- 2.6.2. Distribution of the mass of passengers
  - 2.6.2.1. The mass representing each passenger shall be 75 kg.
  - 2.6.2.2. The mass for each passenger shall be located at the seating reference point (i.e. the 'R point' of the seat)
  - 2.6.2.3. In the case of special purpose vehicle, the requirement of point 2.6.2.2 shall apply mutatis mutandis (for example, mass of an injured person lying on the stretcher in the case of an ambulance).
- 2.6.3. Distribution of the mass of the optional equipment
  - 2.6.3.1. The mass of the optional equipment shall be distributed in accordance with the manufacturer's specifications.
- 2.6.4. Distribution of the pay-mass
  - 2.6.4.1. M<sub>1</sub> vehicles
    - 2.6.4.1.1. As regards M<sub>1</sub> vehicles, the pay-mass shall be distributed in accordance with the manufacturer's specifications in agreement with the technical service.
    - 2.6.4.1.2. As regards motor caravans the minimum pay-mass (PM) shall meet the following requirement:

PM in kg  $\geq 10 (n + L)$

Where

‘*n*’ is the maximum number of passengers plus the driver and

‘*L*’ is the overall length of the vehicle in metre

2.6.4.2.  $N_1$  vehicles

2.6.4.2.1. As regards vehicles with bodywork, the pay-mass shall be distributed uniformly on the cargo bed;

2.6.4.2.2. As regards vehicles without bodywork (e.g. chassis-cab), the manufacturer shall state the extreme permissible positions of the centre of gravity of the pay-mass increased by the mass of the equipment intended to accommodate goods (e.g. bodywork, tank, etc.) (for instance: from 0.50 m to 1.30 m in front of the first rear axle);

2.6.4.2.3. As regards vehicles intended to be fitted with a fifth wheel coupling, the manufacturer shall state the minimum and maximum fifth wheel lead.

2.7. Additional requirements where the vehicle is capable of towing a trailer

2.7.1. The requirements referred to in points 2.2, 2.3 and 2.4 shall apply taking into account the mass of the coupling and the technically permissible maximum mass at the coupling point.

2.7.2. Without prejudice to the requirements of point 2.4, the technically permissible maximum mass on the rear axle(s) may be exceeded by not more than 15 %.

2.7.2.1. Where the technically permissible maximum mass on the rear axle(s) is exceeded by not more than 15 %, the requirements of point 5.2 of Annex II to Commission Regulation (EU) No 458/2011<sup>12</sup> shall apply.

2.7.2.2. In the Member States where the road traffic legislation allows it, the manufacturer may indicate in an appropriate supporting document, such as the owner’s manual or the maintenance book that the technically permissible maximum laden mass of the vehicle may be exceeded by not more than 10 % or 100 kg, whichever value is lower.

This allowance shall apply only when towing a trailer in the conditions specified in point 2.7.2.1 provided that the operating speed is restricted to 100 km/h or less.

### **3. Towable mass and mass at the coupling**

3.1. As regards the technically permissible maximum towable mass, the following

---

<sup>12</sup> OJ L 124, 13.5.2011, p.11.

requirements shall apply:

- 3.1.1. Trailer fitted with a service braking system
  - 3.1.1.1. The technically permissible maximum towable mass of the vehicle shall be the lowest of the following values:
    - (a) the technically permissible maximum towable mass based on the construction features of the vehicle and the strength of the coupling;
    - (b) the technically permissible maximum laden mass of the towing vehicle;
    - (c) 1.5 times the technically permissible maximum laden mass of the towing vehicle in the case of an off-road vehicle as defined in Annex II to Directive 2007/46/EC.
  - 3.1.1.2. However, the technically permissible maximum towable mass shall in no case exceed 3 500 kg.
- 3.1.2. Trailer without a service braking system
  - 3.1.2.1. The permissible towable mass shall be the lowest of the following values:
    - (a) the technically permissible maximum towable mass based on the construction features of the vehicle and the strength of the coupling;
    - (b) half of the mass in running order of the towing vehicle.
  - 3.1.2.2. The technically permissible maximum towable mass shall in no case exceed 750 kg.
- 3.2. The technically permissible maximum mass at the coupling point shall not be less than 4 % of the maximum permissible towable mass and not be less than 25 kg.
- 3.3. The manufacturer shall specify in the owner's manual the technically permissible maximum mass at the coupling point, the mounting points of the coupling on the towing vehicle and the maximum permissible rear overhang for the coupling point.
- 3.4. The technically permissible maximum towable mass shall not be defined by reference to the number of passengers.

#### **4. Mass of the combination**

The technically permissible maximum laden mass of the combination shall not exceed the sum of the technically permissible maximum laden mass plus the technically permissible maximum towable mass.

$$MC \leq M + TM$$

**5. Hill starting ability**

- 5.1. The towing vehicle shall be able to start the vehicle combination five times on an uphill gradient of at least 12 % within five minutes.
- 5.2. In order to conduct the test described in point 5.1., the towing vehicle and the trailer shall be laden as to equal the technically permissible laden mass of the combination.

## **PART B**

### **Vehicles of category M<sub>2</sub> and M<sub>3</sub>**

#### **1. Maximum authorised dimensions**

1.1. The dimensions shall not exceed the following values:

1.1.1. Length

(a) Vehicle with two axles and one section: 13.50 m

(b) Vehicle with three or more axles and one section: 15.00 m

(c) Articulated vehicle: 18.75 m

1.1.2. Width: 2.55 m;

1.1.3. Height: 4.00 m

1.2. For the purposes of measurement of the length, width and height, the vehicle shall be at its mass in running order, placed on a horizontal and flat surface with tyres inflated at the pressure recommended by the manufacturer.

1.3. Only the devices and equipment referred to in Appendix 1 of this Annex shall not be taken into account for the determination of the length, width and height.

#### **2. Mass distribution for vehicles fitted with bodywork**

2.1. Calculation procedure

Notations

' $M$ ' technically permissible maximum laden mass;

' $TM$ ' technically permissible maximum towable mass;

' $MC$ ' technically permissible maximum laden mass of the combination;

' $m_i$ ' technically permissible maximum laden mass on the solo axle designated 'i', where 'i' varies from 1 to the total number of axles of the vehicle;

' $m_c$ ' technically permissible maximum mass at the coupling point;

' $\mu_j$ ' the technically permissible maximum mass on the group of axles designated 'j', where j varies from 1 to the total number of groups of axles.

2.1.1. Suitable calculations shall be carried out in order to make sure that the following requirements are fulfilled for each technical configuration within the type.

2.1.2. In the case of vehicles fitted with loadable axles, the following calculations shall be carried out with the suspension of the axles loaded in the normal operating configuration.

2.2. General requirements

2.2.1. The sum of the technically permissible maximum mass on the solo axles plus the sum of the technically permissible maximum mass on the groups of axles shall not be less than the technically permissible laden mass of the vehicle.

$$M \leq \Sigma [m_i + \mu_j].$$

2.2.2. The mass of the vehicle in running order, plus the mass of the optional equipment, the mass of the passengers, the masses 'WP' and 'B' referred to in point 2.2.3, plus the mass of the coupling if not included in the mass in running order, plus the technical permissible maximum mass at the coupling point shall not exceed the technically permissible maximum laden mass.

2.2.3. Load distribution

2.2.3.1. Notations

'P' number of seating positions, not including the driver and crew member(s);

'Q' mass of one passenger in kg;

'Q<sub>c</sub>' mass of one crew member in kg;

'S<sub>l</sub>' area in m<sup>2</sup> for standing passengers;

'SP' number of standing passengers stated by the manufacturer;

'S<sub>sp</sub>' rated space for one standing passenger in m<sup>2</sup>;

'WP' number of wheelchair spaces multiplied by 250 kg representing the mass of a wheelchair and user;

'V' total volume of baggage compartments in m<sup>3</sup> including luggage compartments, racks and ski-box;

'B' maximum permissible mass of the luggage in kg stated by the manufacturer, including the maximum permissible mass (B') that may be transported in the ski-box if any.

2.2.3.2. the mass Q and Q<sub>c</sub> of the seated passengers shall be located at the seating reference points (i.e. the 'R point' of the seat).

2.2.3.3. The mass corresponding to the number SP of standing passengers of mass Q shall

be uniformly distributed over the surface available for standing passenger  $S_1$ .

- 2.2.3.4. Where appropriate, the mass WP shall be uniformly distributed over each wheelchair space.
- 2.2.3.5. A mass equal to B (kg) shall be uniformly distributed in the luggage compartments.
- 2.2.3.6. A mass equal to B' (kg) shall be located at the centre of gravity of the ski-box.
- 2.2.3.7. The technically permissible maximum mass at the coupling point shall be located at the coupling point the rear overhang of which is stated by the vehicle manufacturer.

2.2.3.8. Values of Q and Ssp values

Vehicle class	Q (kg)	Ssp (m <sup>2</sup> )
Class I and A	68	0.125 m <sup>2</sup>
Class II	71	0.15 m <sup>2</sup>
Class III and B	71	Not applicable

The mass of each crew member shall be 75 kg.

- 2.2.3.9 The number of standing passengers shall not exceed the value  $S_1/S_{sp}$ , where  $S_{sp}$  is the rated space provided for one standing passenger as specified in the table in point 2.2.3.8.
- 2.2.3.10. The value of the maximum permissible mass of the luggage shall be not less than:  
 $B = 100 \times V$

2.2.4. Calculations

- 2.2.4.1 The requirements of point 2.2.2 shall be verified in all interior arrangement configurations.
- 2.2.4.2. In the conditions specified in point 2.2.3 the mass on each solo axle and on each group of axles shall not exceed the technically permissible maximum mass on that axle or group of axles.
- 2.2.4.3. In the case of a vehicle equipped with a variable seating capacity, with an area available for standing passengers ( $S_1$ ) and equipped for the carriage of wheelchairs, compliance with the requirements of points 2.2.2. and 2.2.4.2 shall be verified for each of the following conditions as applicable:
  - (a) with all possible seats occupied followed by the remaining area for standing passengers (up to the standing capacity limit declared by the manufacturer, if reached) and, if space remains, any wheelchair spaces occupied;
  - (b) with all possible standing areas occupied (up to the standing capacity limit stated by the manufacturer) followed by the remaining seats available for

seated passengers and, if space remains, any wheelchair spaces occupied;

- (c) with all possible wheelchair spaces occupied followed by the remaining area for standing passengers (up to the standing capacity limit stated by the manufacturer, if reached) and then the remaining seats available for use occupied.

2.2.5. Where the vehicle is laden as specified in point 2.2.2. the mass corresponding to the load on the front steering axle(s) shall in no case be less than 20 % of the technically permissible maximum laden mass “M”.

2.2.6. Where a vehicle is to be type-approved to more than one class, the requirements of Section 2 shall apply to each class.

### **3. Towing capacity**

3.1. The technically permissible maximum laden mass of the combination shall not exceed the sum of the technically permissible maximum laden mass plus the technically permissible maximum towable mass.

$$MC \leq M + TM$$

3.2. The technically permissible maximum towable mass shall not exceed 3 500 kg.

### **4. Technically permissible maximum mass at the coupling point**

4.1. The technically permissible maximum mass at the coupling point shall be at least equal to 4 % of its technically permissible maximum towable mass, or 25 kg, whichever is the greater.

4.2. The manufacturer shall specify in the owner's manual the conditions for the attachment of the coupling to the motor vehicle.

4.2.1. Where appropriate the conditions referred to in point 4.2. shall include the technically permissible maximum mass at the coupling point of the towing vehicle, the maximum permissible mass of the coupling device, the mounting points of the coupling and the maximum permissible rear overhang of the coupling.

### **5. Hill-starting ability**

5.1. Vehicles designed to tow a trailer shall be capable of starting five times within five minutes at an up-hill gradient of at least 12 %.

5.2. For performing the test described in point 5.1, the towing vehicle and the trailer shall be laden so as to equal the technically permissible maximum laden mass of



the combination.

## **6. Engine power**

- 6.1. The engine shall provide a power output of at least 5 kW per tonne of the technically permissible maximum laden mass of the combination or of the technically permissible maximum laden mass of the solo vehicle where the vehicle is not designed to tow a trailer.
- 6.2. The engine power shall be measured in accordance with Council Directive 80/1269/EEC<sup>13</sup> or UNECE Regulation No 85<sup>14</sup>.

## **7. Manoeuvrability**

- 7.1. The vehicle shall be capable of manoeuvring on either side of a complete trajectory of 360° as shown in figure 1 in Appendix 3 to this Annex without any of the vehicle's outermost points protruding beyond the outer circle or intruding inside the inner circle as the case may be.
  - 7.1.1. The test shall be conducted with the vehicle in both the unladen conditions (i.e. at its mass in running order) and loaded to its technically maximum permissible laden mass.
  - 7.1.2. For the purposes of point 7.1, the parts permitted to protrude beyond the vehicle width referred to in Appendix 1 to this Annex shall not be taken into account.
- 7.2. For vehicles fitted with a loadable axle, the requirement of point 7.1 shall also apply where the loadable axle(s) is in service.
- 7.3. The requirements of section 7.1 shall be verified as follows:
  - 7.3.1. The vehicle shall manoeuvre inside a circular area defined by two concentric circles, the outer circle having a radius of 12.50 m and the inner circle having a radius of 5.30 m
  - 7.3.2. The outermost front point of the motor vehicle shall be guided along the contour of the outer circle (see figure 1 in Appendix 3 to this Annex).

## **8. Rear swing-out**

- 8.1. Vehicle with one section

---

<sup>13</sup> OJ L 375, 31.12.1980, p.46.

<sup>14</sup> OJ L 326, 24.11.2006, p.55.

8.1.1. The vehicle shall be tested in accordance with the drive-in test method described in point 8.1.2.

8.1.2. Drive-in test method

The vehicle shall be stationary, a vertical plane tangential to the side of the vehicle and facing outwards from the circle shall be established by marking a line on the ground.

The vehicle shall be moved from a straight line approach into the circular area described in Figure 1 with its front wheels turned such as the front outermost point follows the contour of the outer circle (see Figure 2a of Appendix 3 to this Annex).

8.1.3. The vehicle shall be set to its mass in running order.

8.1.4. The maximum rear swing-out shall not exceed 0,60 m.

8.2. Vehicles with two or more sections

8.2.1. The requirements of point 8.1. shall apply *mutatis mutandis* as regards vehicles with two or more sections.

In such a case, the two or more rigid sections shall be aligned with the plane as shown in figure 2 b of Appendix 3 to this Annex.

## PART C

### Vehicles of category N<sub>2</sub> and N<sub>3</sub>

#### 1. Maximum authorised dimensions

1.1. The dimensions shall not exceed the following values:

1.1.1. Length: 12.00 m.

1.1.2. Width:

(a) 2.55 m for any vehicle;

(b) 2.60 m for vehicles fitted with a bodywork with insulated walls of at least 45 mm thick, as referred to in Appendix 2 to Annex II to Directive 2007/46/EC;

1.1.3. (c) Height: 4.00 m

1.2. For the purposes of measurement of the length, width and height, the vehicle shall be at its mass in running order, placed on a horizontal and flat surface with tyres inflated at the pressure recommended by the manufacturer.

1.3. Only the devices and equipment referred to in Appendix 1 of this Annex shall not be taken into account for the determination of the length, width and height.

#### 2. Mass distribution for vehicles fitted with bodywork

2.1. Calculation procedure

Notations

' $M$ ' technically permissible maximum laden mass;

' $TM$ ' technically permissible maximum towable mass;

' $MC$ ' technically permissible maximum laden mass of the combination

' $m_i$ ' the technically permissible maximum mass on the solo axle designated 'i', where i varies from 1 to the total number of axles of the vehicle;

' $m_c$ ' technically permissible maximum mass at the coupling point;

' $\mu_j$ ' the technically permissible maximum mass on the group of axles designated 'j', where j varies from 1 to the total number of groups of axles.

2.1.1. Suitable calculations shall be carried out in order to make sure that the requirements set out in points 2.2. and 2.3. are fulfilled for each technical

configuration within the type.

2.1.2. In the case of vehicles fitted with loadable axles, the calculations required under points 2.2. and 2.3. shall be carried out with the suspension of loadable axles in the normal running configuration.

2.1.3. In the case of vehicles fitted with lift axles, the calculations required under points 2.2. and 2.3. shall be carried out with the axles lowered.

## 2.2. General requirements

2.2.1. The sum of the technically permissible maximum mass on the solo axles plus the sum of the technically permissible maximum mass on the groups of axles shall not be less than the technically permissible maximum laden mass of the vehicle.

$$M \leq \Sigma [m_i + \mu_j]$$

2.2.2. For each group of axles designated 'j', the sum of the technically permissible maximum mass on its axles shall not be less than the technically permissible maximum mass on the group of axles.

In addition, each of the masses  $m_i$  shall not be less than the part of  $\mu_j$  applying on the axle 'i' as determined by the mass distribution for that group of axles.

## 2.3. Specific requirements

2.3.1. The mass of the vehicle in running order, plus the mass of the optional equipment plus the mass of the passengers, plus the mass of the coupling if not included in the mass in running order plus the technically permissible maximum mass at the coupling point shall not exceed the technically permissible maximum laden mass of the vehicle.

2.3.2. Where the vehicle is laden to its technically permissible maximum laden mass, the mass distributed on an axle 'i' shall not exceed the mass  $m_i$  on that axle, and the mass on the group of axles 'j' shall not exceed the mass  $\mu_j$ .

2.3.3. The requirements of point 2.3.2. shall be complied with in the following load configurations:

2.3.3.1. uniform distribution of the pay-mass:

the vehicle shall be at its mass in running order plus the mass of the optional equipment plus the mass of the passengers located at the seating reference points, plus the mass of the coupling (if not included in the mass in running order, plus the maximum permissible mass at the coupling point, plus the pay-mass being distributed uniformly on the cargo area.

2.3.3.2. non-uniform distribution of pay-mass:

the vehicle shall be at its mass in running order plus the mass of the optional equipment plus the mass of the passengers located at the seating reference points, plus the mass of the coupling (if not included in the mass in running order, plus

the maximum permissible mass at the coupling point, plus the pay-mass located in accordance with the manufacturers specifications.

For such purposes the manufacturer shall state the extreme permissible possible positions of the centre of gravity of the pay-mass and/or body and/or equipment or interior fittings (for instance: from 0.50 m to 1.30 m in front of the first rear axle).

2.3.3.3. combination of uniform and non-uniform distribution:

The requirements of points 2.3.3.1. and 2.3.3.2 shall be fulfilled simultaneously.

Example, a tipper lorry (distributed load) equipped with an additional crane (localised load).

2.3.3.4. mass transferred by the fifth wheel coupling (tractor unit for semi-trailer):

the vehicle shall be at its mass in running order plus the mass of the optional equipment plus the mass of the passengers located at the seating reference points, plus the mass of the coupling if not included in the mass in running order, plus the maximum permissible mass at the fifth wheel coupling point located in accordance with the manufacturers' specifications (minimum and maximum fifth-wheel lead).

2.3.3.5. The requirements of points 2.3.3.1. shall always be fulfilled where the vehicle is fitted with a flat cargo area.

2.3.4. Where the vehicle is laden to its technically permissible maximum laden mass, plus the mass of the coupling if not included in the mass in running order, plus the maximum permissible mass at the coupling point in such a way that the maximum permissible maximum mass on the rear group of axle ( $\mu$ ) or the maximum permissible maximum on the rear axle (m) is reached, the mass on the front steering axle(s) shall not be less than 20 % of the technically permissible maximum laden mass of the vehicle.

2.3.5. As regards special purposes vehicles of category N<sub>2</sub> and N<sub>3</sub>, the technical service shall check compliance with the requirements of Section 2 in agreement with the manufacturer, taking into account the specific design of the vehicle (for example, mobile cranes).

### 3. Towing capacity

3.1. The technically permissible maximum laden mass of the combination shall not exceed the sum of the technically permissible maximum laden mass plus the technically permissible maximum towable mass.

$$MC \leq M + TM$$

### 4. Hill-starting ability and gradeability

- 4.1. Vehicles designed to tow a trailer and laden to their technically permissible maximum laden mass of the combination shall be capable of starting five times within five minutes at an up-hill gradient of at least 12 %.
- 4.2. As regard gradeability, off road vehicles shall be tested against the technical requirements of Annex II.
- 4.2.1. The requirements of Section 5 of Appendix 1 to Annex II of Directive 2007/46/EC shall also apply.

## **5. Engine power**

- 5.1. Vehicles shall provide an engine power output of at least 5 kW per tonne of the technically permissible maximum laden mass of the combination.
- 5.1.1. In the case of a road tractor or a tractor unit for semi-trailer intended for the transport of indivisible loads, the engine power shall be at least 2 kW per tonne of the technically permissible maximum laden mass of the combination.
- 5.2. The engine power shall be measured of in accordance with Council Directive 80/1269/EEC or UNECE Regulation No 85.

## **6. Manoeuvrability**

- 6.1. The vehicle shall be capable of manoeuvring on either side of a complete trajectory of 360° as shown in figure 1 of Appendix 3 to this Annex without any of the vehicle's outermost points protruding beyond the outer circle or intruding inside the inner circle as the case may be.
- 6.1.1. The test shall be conducted with the vehicle in both the unladen conditions (i.e. at its mass in running order) and loaded to its technically maximum permissible laden mass.
- 6.1.2. For the purposes of point 6.1, the parts permitted to protrude beyond the vehicle width referred to in Appendix 1 to this Annex shall not be taken into account.
- 6.2. For vehicles fitted with axle-lift devices, the requirement of point 6.1. shall also apply with the lift axle(s) in the lifted position and where the loadable axle(s) is in service.
- 6.3. The requirements of point 6.1. shall be verified as follows
- 6.3.1. The vehicle shall manoeuvre inside an area defined by two concentric circles, the outer circle having a radius of 12.50 m and the inner circle having a radius of 5.30 m
- 6.3.2. The outermost front point of the motor vehicle shall be guided along the contour

of the outer circle (see figure 1 of Appendix 3 to this Annex)

**7. Maximum rear swing-out**

7.1. The vehicle shall be tested in accordance with the steady-state test method described in point 7.1.1.

7.1.1. Steady-state test method

7.1.1.2. The vehicle shall be stationary and shall have its front steered wheels so directed that if the vehicle moves, its outermost point would describe a circle of 12.50 m radius.

A vertical plane tangential to the side of the vehicle and facing outwards from the circle shall be established by marking a line on the ground.

The vehicle shall move forward such as the front outermost point follows the contour of the outer circle of 12.50 m radius.

7.2. The maximum rear swing-out shall not exceed: (see figure 3 of Appendix 3 to this Annex)

- (a) 0.80 m;
- (b) 1.00 m where the vehicle is fitted with an axle-lift device and the axle is cleared off the ground;
- (c) 1.00 m where the rearmost axle is a steered axle.

## **PART D**

### **Vehicles of category O**

#### **1. Maximum authorised dimensions**

1.1. The dimensions shall not exceed the following values:

1.1.1. Length

- (a) Trailer: 12.00 m including drawbar;
- (b) Semi-trailer: 12.00 m plus the front overhang.

1.1.2. Width

- (a) 2.55 m for any vehicle;
- (b) 2.60 m for vehicles fitted with a bodywork with insulated walls of at least 45 mm thick, as referred to in Appendix 2 to Annex II to Directive 2007/46/EC.

1.1.3. Height: 4.00 m.

1.1.4. Front fitting radius of semi-trailer: 2.04 m.

1.2. For the purposes of measurement of the length, width and height, the vehicle shall be at its mass in running order, placed on a horizontal and flat surface with tyres inflated at the pressure recommended by the manufacturer.

1.3. The measurement of the length, height and front fitting radius shall be conducted where the loading surface or the reference surface referred to in point 1.2.1. second sub-paragraph of Annex 7 to UNECE Regulation No 55 is horizontal.

Adjustable drawbars shall be horizontal and aligned with the centre-line of the vehicle. They shall be set at their horizontal most elongated position.

1.4. Only the devices and equipment referred to in Appendix 1 to this Annex shall not be taken into account for the determination of the dimensions referred to in point 1.1.

#### **2. Mass distribution for vehicles fitted with bodywork**

2.1. Calculation procedure

Notations

' $M$ ' technically permissible maximum laden mass;



- ' $m_0$ ' technically permissible maximum mass at the front coupling point;
- ' $m_i$ ' the technically permissible maximum mass on the axle designated 'i', where i varies from 1 to the total number of axles of the vehicle;
- ' $m_c$ ' technically permissible maximum mass at the rear coupling point;
- ' $\mu_j$ ' the technically permissible maximum mass on the group of axles designated 'j', where j varies from 1 to the total number of groups of axles.

2.1.1. Suitable calculations shall be carried out in order to make sure that the requirements set out in points 2.2. and 2.3. are fulfilled for each technical configuration within the type.

2.1.2. In the case of vehicles fitted with loadable axles, the calculations required under points 2.2. and 2.3. shall be carried out with the suspension of loadable axles in the normal running configuration.

2.1.3. In the case of vehicles fitted with lift axles, the calculations required under points 2.2. and 2.3. shall be carried out with the axles lowered.

## 2.2. General requirements

2.2.1. The sum of the technically permissible maximum mass at the front coupling point plus the technically permissible maximum mass on the solo axles or group of axles plus the technically permissible maximum mass at the rear coupling point shall be not less than the technically permissible maximum laden mass of the vehicle.

$$M \leq \Sigma [m_0 + m_i + \mu_j + m_c]$$

2.2.2. For each group of axles designated 'j', the sum of the masses  $m_i$  on its axles shall not be less than the mass  $\mu_j$ .

In addition, each of the masses  $m_i$  shall not be less than the part of  $\mu_j$  applying on the axle 'i' as determined by the mass distribution for that group of axles.

## 2.3. Specific requirements

2.3.1. The mass of the vehicle in running order, plus the mass of the optional equipment plus the technically permissible maximum mass at the coupling point(s) shall not exceed the technically permissible maximum laden mass of the vehicle.

2.3.2. Where the vehicle is laden to its technically permissible maximum laden mass, the mass distributed on a solo axle 'i' shall neither exceed the mass  $m_i$  on that axle, nor the mass  $\mu_j$  on the group of axles, nor the technically permissible maximum mass at the coupling point  $m_0$ .

2.3.3. The requirements of point 2.3.2. shall be complied with in the following load configurations:

2.3.3.1. uniform distribution of the pay-mass

The vehicle shall be at its mass in running order plus the mass of the optional equipment plus the pay-mass being distributed uniformly on the cargo area;

2.3.3.2. non-uniform distribution of the pay-mass

The vehicle shall be at its mass in running order plus the mass of the optional equipment plus the pay-mass located in accordance with the manufacturer's specifications.

For such purposes the manufacturer shall state the extreme permissible possible positions of the centre of gravity of the pay-mass and/or body and/or equipment or interior fittings (for instance: from 0.50 m to 1.30 m in front of the first rear axle);

2.3.3.3 combination of uniform and non-uniform distribution:

The requirements of points 2.3.3.1. and 2.3.3.2 shall be fulfilled simultaneously.

2.3.3.4. The requirements of points 2.3.3.1. shall always be fulfilled where the vehicle is fitted with a flat cargo area.

2.3.4. Specific requirements for trailer caravans

2.3.4.1 The minimum pay-mass (PM) shall meet the following requirement:

$$PM \text{ in kg} \geq 10 (n + L)$$

Where

'*n*' is the maximum number of berths and

'*L*' is the overall length of the body length as defined in point 6.1.2. of Standard ISO 7237:1981.

### 3. Manoeuvrability requirements

3.1. Trailers and semi-trailers shall be so designed that, when coupled to a towing vehicle, the combination is capable of manoeuvring on either side of a complete trajectory of 360° made up of two concentric circles, the outer circle having a radius of 12.50 m and the inner circle having a radius of 5.30 m without any of the vehicle's outermost points of the towing vehicle protruding beyond the outer circle or any of the outermost points of the trailer or semi-trailer intruding inside the inner circle.

3.2. A semi-trailer shall be deemed to comply with the requirement of point 3.1. if its reference wheelbase 'RWB' meets the following requirement:

$$RWB \leq [(12.50 - 2.04)^2 - (5.30 + \frac{1}{2} W)^2]^{1/2}$$

where:

'*RWB*' is the distance between the king-pin axis and the centre line of the non-steering axles.

'*W*' is the semi-trailer's width

- 3.3. Where one or more of the non-steering axles has an axle lift device the reference wheelbase with the axle lowered or the axle lifted - whichever is the longest - shall be taken into account.

## Appendix 1

### List of devices and equipment that are not required to be taken into account for the determination of the outermost dimensions

1. Subject to the additional restrictions provided in the following tables, the devices and equipment listed in Tables I, II and III are not required to be taken into account for the determination of the outermost dimensions where the following requirements are fulfilled:
  - (a) Where several devices are fitted at the front, the total protrusion of those devices shall not exceed 250 mm;
  - (b) The total protrusion of devices and equipment added to the length of the vehicle shall not exceed 750 mm;
  - (c) With the exception of rear-view mirrors, the total protrusion of devices and equipment added to the width of the vehicle shall not exceed 100 mm.
2. The requirements set out in points (a) and (b) of paragraph 1 shall not apply to devices for indirect vision.

TABLE I: Vehicle length											
Item		Vehicles categories									
		M <sub>1</sub>	M <sub>2</sub>	M <sub>3</sub>	N <sub>1</sub>	N <sub>2</sub>	N <sub>3</sub>	O <sub>1</sub>	O <sub>2</sub>	O <sub>3</sub>	O <sub>4</sub>
1.	Devices for indirect vision as defined in point 2.1. of UNECE Regulation No 46 <sup>15</sup>	x	x	x	x	x	x	x	x	x	x
2.	Wiper and washer devices	x	x	x	x	x	x				
3.	External sun visors	-	-	-	-	x	x	-	-	-	-
4.	Frontal protection system type-approved in accordance with Regulation (EC) No 78/2009 of the European Parliament and of the Council <sup>16</sup>	x			x						
5.	Access steps and hand-holds	-	x	x	x	x	x	x	x	x	x

<sup>15</sup> OJ L 177, 10.7.2010, p. 211.

<sup>16</sup> OJ L 35, 4.2.2009, p. 1.

6.	Coupling (when removable)	X	X	X	X	X	X	-	-	-	-
7.	Additional coupling at the rear of a trailer (when removable)	-	-	-	-	-	-	X	X	X	X
8.	Bike carrier (when removable or retractable)	X			X	-	-	-	-	-	-
9.	Lift platforms, access ramps or similar equipment (when they are in undeployed position and do not protrude by more than 300 mm) provided that the loading capacity of the vehicle is not increased.	X	X	X	X	X	X	X	X	X	X
10.	Warning and detection aids including radars	-	X	X	-	X	X	X	X	X	X
11.	Resilient buffers and similar equipment	-	-	-	-	X	X	X	X	X	X
12.	Custom sealing devices and their protections	-	-	-	X	X	X	X	X	X	X
13.	Devices for securing the tarpaulin and their protection	-	-	-	X	X	X	X	X	X	X
14.	Length stops for demountable bodies	-	-	-	-	X	X	X	X	X	X
15.	Trolley booms of electrically-propelled vehicles	-	-	X	-	-	-	-	-	-	-
16.	Front or rear marking plates	-	X	X	-	X	X	X	X	X	X
17.	Optional lamps as defined in Section 2 of UNECE Regulation No 48 <sup>17</sup> .	X	X	X	X	X	X	X	X	X	X
18.	Foldable devices and equipment designed to reduce aerodynamic drag provided that they do not protrude at the back by more than 500 mm from the outermost length of the vehicle and they do not increase the length of the loading area.	-	X	X	-	X	X	-	-	X	X

<sup>17</sup> OJ L 135, 23.5.2008, p.1.

	Such devices must be designed so as to be retractable when the vehicle is at stand-still in such a way that the maximum authorised length is not exceeded and they do not impair the capability of the vehicle to be used for intermodal transport.										
--	---	--	--	--	--	--	--	--	--	--	--

TABLE II: Vehicle width											
Item		Vehicles categories									
		M <sub>1</sub>	M <sub>2</sub>	M <sub>3</sub>	N <sub>1</sub>	N <sub>2</sub>	N <sub>3</sub>	O <sub>1</sub>	O <sub>2</sub>	O <sub>3</sub>	O <sub>4</sub>
1.	Devices for indirect vision as defined in point 2.1. of UNECE Regulation No 46	X	X	X	X	X	X	X	X	X	X
2.	The deflected part of the tyre walls at the point of contact with the road surface	X	X	X	X	X	X	X	X	X	X
3.	Tyre failure tell-tale devices	-	-	X	X	X	X	X	X	X	X
4.	Tyre-pressure indicators	-	-	X	X	X	X	X	X	X	X
5.	Side-marker lamps	X	X	X	X	X	X	X	X	X	X
6.	Lighting equipment										
	6.1. End-outline marker lamps	X	X	X	X	X	X	X	X	X	X
	6.2. Side-retro-reflectors	X	X	X	X	X	X	X	X	X	X
	6.3. Direction-indicator lamps	X	X	X	X	X	X	X	X	X	X
	6.4. Rear position lamps	-	-	-	-	X	X	X	X	X	X
	6.5. Service-door lighting systems	-	X	X	-	-	-	-	-	-	-
7.	access ramps , lift platforms and similar equipment (when undeployed and provided that they do not exceed 10 mm from the side	-	X	X	-	X	X	X	X	X	X

	of the vehicle and the corners of the ramps facing forwards or rearwards are rounded to a radius of not less than 5 mm; the edges must be rounded to a radius of not less than 2,5 mm										
8.	retractable lateral guidance devices intended for use on guided bus system, if not retracted.	-	-	X	-	-	-	-	-	-	-
9.	Retractable steps when deployed and the vehicle is in stand-still position;	X	X	X	X	X	X	X	X	X	X
10.	Watching and detection aids including radars	-	X	X		X	X	X	X	X	X
11.	<p>Devices and equipment especially designed to reduce aerodynamic drag provided that they do not protrude by more than 50 mm on each side from the outermost width of the vehicle and they do not increase the loading capacity.</p> <p>Such devices must be designed so as to be retractable when the vehicle is at stand-still in such a way that the maximum authorised width is not exceeded and they do not impair the capability of the vehicle to be used for intermodal transport.</p> <p>Where the devices and equipment are in service, the vehicle width shall not exceed 2 650 mm.</p>	-	-	-	X	X	X	X	X	X	X
12.	Customs sealing devices and their protection	-	-	-	X	X	X	X	X	X	X
13.	Devices for securing the tarpaulin and their protection not projecting by more than 20 mm where they are no more than 2.0 m from the ground level and no more than 50 mm where they are more than 2.0 m from the ground level. The edges shall be rounded to a	-	-	-	X	X	X	X	X	X	X

	radius of not less than 2,5 mm.										
14.	Protruding flexible parts of a spray-suppression system referred to in Commission Regulation (EU) No 109/2011 <sup>18</sup> .	-	-	-	-	X	X	-	-	X	X
15	Flexible mudguards not covered under entry 14.	-	X	X	X	X	X	X	X	X	X
16.	Snow chains	X	X	X	X	X	X	X	X	X	X
17.	Safety railings on vehicle transporters.  Only for vehicles designed and constructed to transport at least two other vehicles and for which the safety railings are more than 2.0 m but not more than 3.70 m from the ground and do not project by more than 50 mm from the outermost side of the vehicle.  The vehicle width shall not exceed 2 650 mm.	-	-	-	-	X	X	-	-	X	X

TABLE III: Vehicle height											
		<b>M<sub>1</sub></b>	<b>M<sub>2</sub></b>	<b>M<sub>3</sub></b>	<b>N<sub>1</sub></b>	<b>N<sub>2</sub></b>	<b>N<sub>3</sub></b>	<b>O<sub>1</sub></b>	<b>O<sub>2</sub></b>	<b>O<sub>3</sub></b>	<b>O<sub>4</sub></b>
1.	Radio or radio-navigation antenna	X	X	X	X	X	X	X	X	X	X
2.	Pantographs or trolley booms in their elevated position	-	-	X	-	-	-	-	-	-	-

<sup>18</sup> OJ L 34, 9.2.2011, p. 2.



## Appendix 2

### Permissible deviations for type-approval and conformity of production

#### **1. Dimensions**

- 1.1. Measurement of the overall length, width and height shall be carried out in accordance with point 1.2. of Parts A to D of this Annex.
- 1.2. Under the condition that the limits specified in point 1.1 of Part A to D of this Annex are not exceeded, the actual dimensions may differ from those stated by the manufacturer by not more than 3 %.

#### **2. Mass in running order and actual mass of the vehicle**

- 2.1. The mass in running order shall be checked from the actual mass by weighing the vehicle and deducting the mass of the optional equipment fitted. For such purposes the weighing instrument shall comply with the requirements of Directive 2009/23/EC of the European Parliament and of the Council<sup>19</sup>.
- 2.2. The mass in running order determined in accordance with the requirements of point 2.1. may deviate from the nominal value stated in point 2.6(b) of Annex I or in Part I, section A or B of Annex III to Directive 2007/46/EC or in the relevant entry of the certificate of conformity by not more than:
  - (a) 3 % as regards the permissible lower and upper deviations (= the negative and positive deviation around the declared value) as regards M, N and O vehicles with the exception of special purpose vehicles;
  - (b) 5 % as regards the permissible lower and upper deviations (= the negative and positive deviation around the declared value) as regards special purpose vehicles;
  - (c) 5 % as regards the permissible lower and upper deviations (= the negative and positive deviation around the declared value) for the purposes of Article 12(2) of Directive 2007/46/EC.

---

<sup>19</sup> OJ L 122, 16.5.2009, p.6.

### Appendix 3

#### Figures regarding manoeuvrability requirements

Figure 1 : Manoeuvrability circle  $r = 5.3 \text{ m}$   $R = 12.5 \text{ m}$

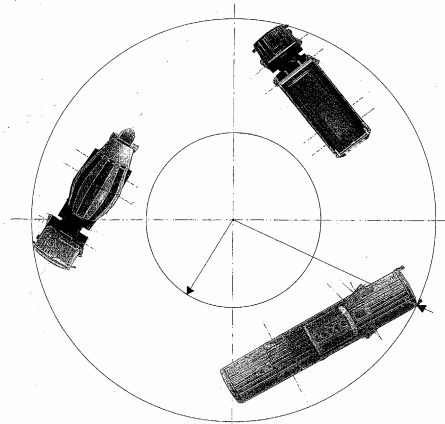

Figure 2: Drive-in method for  $M_2$  and  $M_3$  vehicles

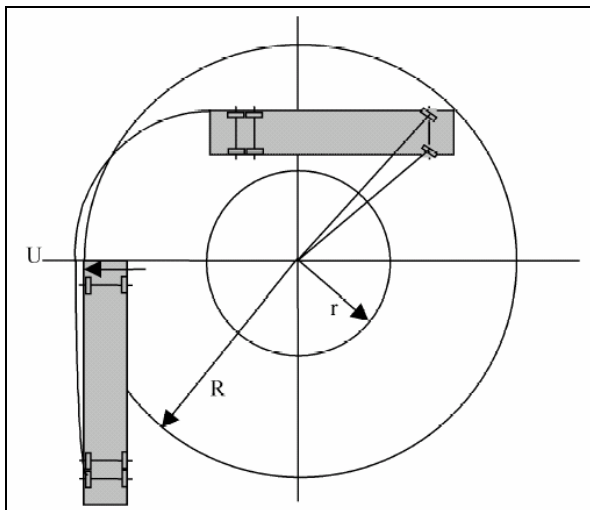

Figure 2a : rear swing-out (non-articulated vehicles)

$R = 12.5 \text{ m}$   
 $r = 5.3 \text{ m}$   
 $U_{\max} \leq 60 \text{ cm}$

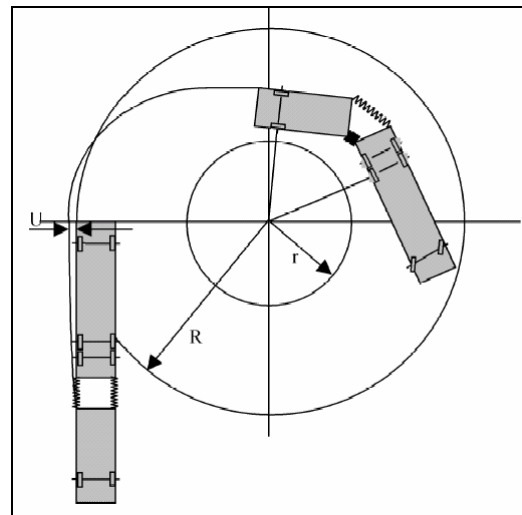
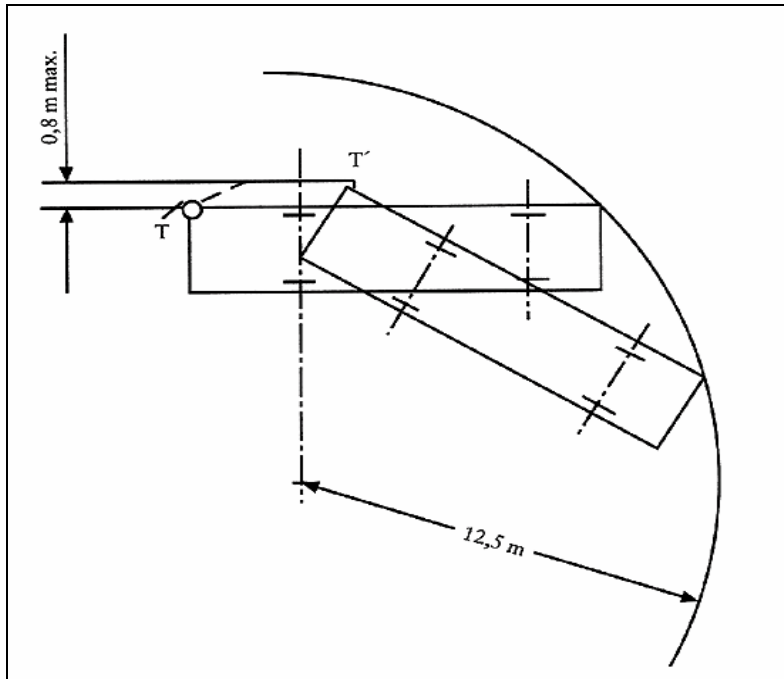

Figure 2b : rear swing-out (articulated vehicles)

$R = 12.5 \text{ m}$   
 $r = 5.3 \text{ m}$   
 $U_{\max} \leq 60 \text{ cm}$

Figure 3: steady-state method for  $N_2$  and  $N_3$  vehicles



## **ANNEX II**

### **Gradeability of off-road vehicles**

#### **1. General**

- 1.1. This Annex lays down the technical requirements for the purposes of verifying the gradeability of a vehicle in order to be categorised as off-road vehicle in accordance with Section 4 of Part A of Annex II to Directive 2007/46/EC.
- 1.2. The technical service shall verify if the complete or completed vehicle, or tractor unit for semi-trailer is to be considered as an off-road vehicle in accordance with the requirements laid down in Annex II to 2007/46/EC.
- 1.3. For incomplete vehicles, this verification shall be carried out only at the request of the manufacturer.

#### **2. Test conditions**

##### 2.1. Vehicle conditions

- 2.1.1. The vehicle shall be set in the conditions recommended by the manufacturer and fitted with the equipment referred to in Annex I to Directive 2007/46/EC.
- 2.1.2. The adjustment of the brakes, clutch (or equivalent), engine and gear box shall be set in accordance with the manufacturer's recommendations for the purposes of use off the normal roads.
- 2.1.3. The tyres shall be those recommended for off-roads use. They shall have a tread depth of not less than 90 % of the tread depth of a new tyre. The tyre pressure shall be adjusted to the value recommended by the tyre manufacturer.
- 2.1.4. The vehicle shall be loaded at its technically permissible maximum laden mass with a load distribution proportional to the distribution of the maximum mass on the axles as stated by the manufacturer.

For example a vehicle of 7.5 tonnes with a maximum mass on the front axle of 4 tonnes and a maximum mass on the rear axle of 6 tonnes shall be tested with a mass of 3 tonnes (40 %) on the front axle and 4.5 tonnes (60 %) on the rear axle.

##### 2.2. Test track conditions

- 2.2.1. The surface of the test track shall be dry, made of asphalt or concrete
- 2.2.2. The gradient shall show a continuous percentage of 25 % with a tolerance of + 3% ( $\theta = 14$  degrees).
- 2.2.3. In agreement with the manufacturer, the test may be performed on a gradient that shows a percentage greater than 25 %. The test shall be conducted with maximum

masses reduced in relation to the test conditions.

These conditions shall be reported.

- 2.2.4. The surface of the track shall show a good coefficient of adhesion.

The Skid Resistance Index ('SRI') of the surface shall be measured in accordance with Standard CEN/TS 13036-2 : 2010 Road and airfield surface characteristics – Test methods – Part 2: Assessment of the skid resistance of a road pavement surface by use of dynamic measuring systems.

The mean value of the SRI shall be reported.

### **3. Test procedure**

- 3.1. The vehicle shall be first placed on a horizontal surface.
- 3.2. The mode of traction shall be set as for off-roads use. The gear(s) engaged shall allow a steady speed.
- 3.3. Sections 4 and 5 of Appendix 1 to Annex II to Directive 2007/46/EC shall apply.

## ANNEX III

### Conditions of equivalence of a suspension to air-suspension

1. This Annex lays down the technical conditions relating to the equivalence of a suspension to air-suspension for vehicle driving axle(s).
2. In order to be recognised as equivalent to air suspension, a suspension shall comply with the following requirements:
  - 2.1. During free transient low-frequency vertical oscillation of the sprung mass above a driving axle or group of axles, the measured frequency and damping with the suspension carrying its maximum load shall fall within the limits defined in points 2.3. to 2.6.
  - 2.2. Each axle shall be fitted with hydraulic dampers. On groups of axles, the dampers shall be positioned to minimise the oscillation of the groups of axles.
  - 2.3. The mean damping ratio  $D_m$  shall be more than 20 % of critical damping for the suspension in its normal condition with hydraulic dampers in place and operating.
  - 2.4. The damping ratio  $D_r$  of the suspension with all hydraulic dampers removed or incapacitated shall be not more than 50 % of  $D_m$ .
  - 2.5. The frequency of the sprung mass above the driving axle or group of axles in a free transient vertical oscillation shall not be higher than 2.0 Hz.
  - 2.6. The test procedures for measuring the frequency and damping shall be laid down in point 3.
3. Test procedure
  - 3.1. Frequency and damping
    - 3.1.1. The free oscillation of the sprung mass shall be given by the following equation:

$$M \frac{d^2Z}{dt^2} + C \frac{dZ}{dt} + KZ = 0$$

Where

‘M’ is the sprung mass (kg),

‘Z’ is the vertical displacement of the sprung mass (m),

‘C’ is the total damping coefficient (N.s/m) and

‘K’ Is the total vertical stiffness between the road surface and the sprung mass (N/m).

- 3.1.2. The frequency of oscillation ('F' in Hz) of the sprung mass shall be given by the following equation:

$$F = \frac{1}{2\pi} \sqrt{\frac{K}{M} - \frac{C^2}{4M^2}}$$

- 3.1.3. The damping is critical when  $C = C_0$   
where

$$C_0 = 2\sqrt{KM}$$

The damping ratio as a fraction of critical is  $C/C_0$

- 3.1.4. During free transient oscillation of the sprung mass the vertical motion of the mass will follow a damped sinusoidal path (figure 2). The frequency can be estimated by measuring the time for as many cycles of oscillation as can be observed. The damping can be estimated by measuring the heights of successive peaks of the oscillation in the same direction.
- 3.1.5. If the peak amplitudes of the first and second cycles of the oscillation are  $A_1$  and  $A_2$ , then the damping ratio  $D$  is given by the following equation:

$$D = \frac{C}{C_0} = \frac{1}{2\pi} \ln \frac{A_1}{A_2}$$

"ln" being the natural logarithm of the amplitude ratio.

### 3.2. Test procedure

To establish by test the damping ratio  $D_m$ , the damping ratio  $D_r$ , with hydraulic dampers removed, and the frequency  $F$  of the suspension, the loaded vehicle shall be either:

- (a) driven at low speed ( $5 \text{ km/h} \pm 1 \text{ km/h}$ ) over an 80 mm step with the profile shown in figure 1. The transient oscillation to be analysed for frequency and damping occurs after the wheels of the driving axle have left the step;
- (b) pulled down by its chassis so that the driving axle load is 1,5 times its maximum static value. The vehicle held down is suddenly released and the subsequent oscillation analysed;
- (c) pulled up by its chassis so that the sprung mass is lifted by 80 mm above the driving axle. The vehicle held up is suddenly dropped and the subsequent

oscillation analysed;

- (d) subjected to other procedures insofar as it has been proved by the manufacturer, to the satisfaction of the technical service, that they are equivalent.

### 3.3. Test equipment of the vehicle and loading conditions

3.3.1 The vehicle shall be fitted with a vertical displacement transducer between driving axle and chassis, directly above the driving axle. From the trace, the time interval between the first and second compression peaks shall be measured to obtain the damping.

For twin driving groups of axles, vertical displacement transducers shall be fitted between each driving axle and the chassis directly above it.

3.3.2. The tyres shall be inflated to the appropriate pressure recommended by the manufacturer.

3.3.3 The test for verifying the equivalence of the suspensions shall be made at the technically permissible maximum mass on the axle or group of axles, and the equivalence assumed to cover all the lower masses.

Figure 1  
Step for suspension tests

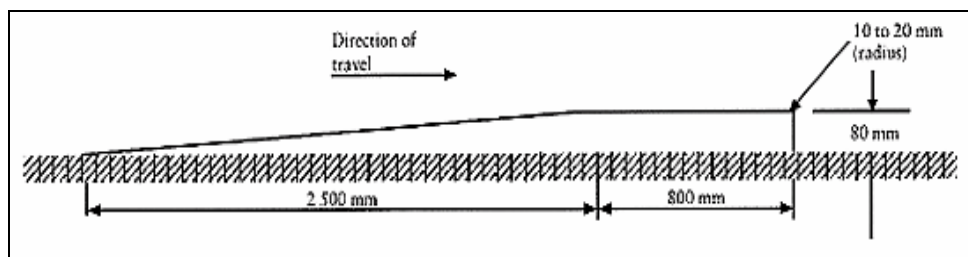
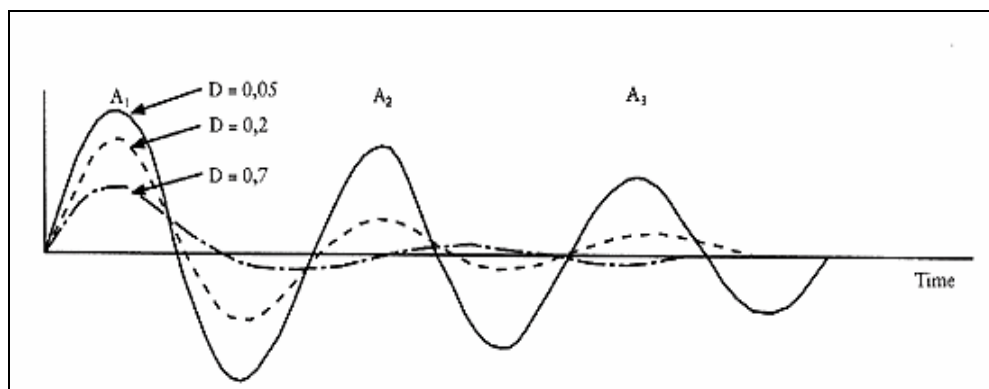

Figure 2  
A damped transient response





## ANNEX IV

### Technical requirements for the installation of lift- or loadable axle(s) on vehicles

1. If a vehicle is fitted with one or more lift- or loadable axles it shall be ensured that under normal driving conditions the registration/in-service maximum permissible masses on solo axles or groups of axles are not exceeded. To that end the lift- or loadable axle(s) shall be lowered to the ground or be loaded automatically if the nearest axle(s) of the group or the front axle(s) of the motor vehicle is/are laden to its/their registration/in- service maximum permissible mass(es).

Where a lift axle is in elevated position, it shall be ensured that the mass on the steering axle(s) continues to be sufficient to ensure the safe driving of the vehicle in all circumstances. For such purposes, the vehicle manufacturer shall specify, in the case of incomplete vehicles, the minimum mass on the steering axle(s).

2. Every axle-lift device fitted to a vehicle, as well as the systems for its operation, shall be designed and installed in such a manner as to protect them against any improper use or tampering.
3. Requirements for moving off vehicles on slippery surfaces and to improve their manoeuvrability
  - 3.1. By way of derogation from the requirements of point 1 and to help motor vehicles or vehicle combinations to move off on slippery ground and to increase the traction of the tyres on these surfaces as well to improve their manoeuvrability, the axle lift device may actuate the lift- or loadable axle(s) of a motor vehicle or semi-trailer to increase or decrease the mass on the driving axle of the motor vehicle, subject to the following conditions:
    - (a) the mass corresponding to the load on each axle of the vehicle may exceed the maximum authorised mass on the axle in force in the Member State by up to 30 % provided it does not exceed the value stated by the manufacturer for this special purpose;
    - (b) the mass corresponding to the remaining load on the front axle(s) shall remain above zero (i.e. in case of a rear loadable axle with long rear overhang, the vehicle may not tip up);
    - (c) the lift- or loadable axle(s) shall be actuated only by a specific control;
    - (d) after the vehicle has moved off and before its speed exceeds 30 km/h, the axle(s) shall automatically be lowered again to the ground or be reloaded.

**ANNEX V**

**PART A**

**Information document**

MODEL TO BE USED

Information document No ... relating to the EC type-approval of a motor vehicle and their trailers with regard the masses and dimensions of a vehicle.

The following information shall be supplied in triplicate and include a list of contents. Any drawings shall be supplied in appropriate scale and in sufficient detail on size A4 or on a folder of A4 format. Photographs, if any, shall show sufficient detail.

**0. GENERAL**

- 0.1. Make (trade name of manufacturer): .....
- 0.2. Type: .....
- 0.2.1. Commercial name(s) (if available): .....
- 0.4. Category of vehicle (°): .....
- 0.5. Company name and address of manufacturer: .....
- 0.8. Name(s) and address(es) of assembly plant(s): .....
- 0.9. Name and address of the manufacturer's representative (if any): .....

**1. GENERAL CONSTRUCTION CHARACTERISTICS OF THE VEHICLE**

- 1.1. Photographs and/or drawings of a representative vehicle: .....
- 1.2. Dimensional drawing of the whole vehicle: .....
- 1.3. Number of axles and wheels: .....
- 1.3.1. Number and position of axles with twin wheels: .....
- 1.3.2. Number and position of steered axles: .....
- 1.3.3. Powered axles (number, position, interconnection): .....
- 1.4. Chassis (if any) (overall drawing): .....
- 1.7. Driving cab (forward control or bonneted) (°): .....

- 1.9. Specify if the towing vehicle is intended to tow semi-trailers or other trailers and, if the trailer is a semi-, drawbar-, centre-axle- or rigid drawbar trailer: ....
- 1.10. Specify if the vehicles is specially designed for the controlled-temperature carriage of goods: .....
- 2. MASSES AND DIMENSIONS <sup>(f)</sup> <sup>(g)</sup> <sup>(7)</sup>**  
(in kg and mm) (Refer to drawing where applicable)
- 2.1. Wheel base(s) (fully loaded) <sup>(g1)</sup>:** .....
- 2.1.1. Two-axle vehicles:.....
- 2.1.2. Vehicles with three or more axles
- 2.1.2.1. Axle spacing between consecutive axles going from the foremost to the rearmost axle: .....
- 2.1.2.2. Total axle spacing:.....
- 2.2. Fifth wheel**
- 2.2.1. In the case of semi-trailers
- 2.2.1.1. Distance between the axis of the fifth wheel kingpin and the rearmost end of the semi-trailer:.....
- 2.2.1.2. Maximum distance between the axis of the fifth wheel king pin and any point on the front of the semi-trailer:.....
- 2.2.1.3. Semi-trailer reference wheelbase (as required in point 3.2. of Part D of Annex I to Regulation [...*this Regulation – to be filled in by OPOCE*]): .....
- 2.2.2. In the case of semi-trailer towing vehicles
- 2.2.2.1. Fifth wheel lead (maximum and minimum; indicate the permissible values in the case of an incomplete vehicle) <sup>(g2)</sup>: .....
- 2.3. Axle track(s) and width(s)**
- 2.3.1. Track of each steered axle <sup>(g4)</sup>:.....
- 2.3.2. Track of all other axles <sup>(g4)</sup>:.....
- 2.4. Range of vehicle dimensions (overall)**
- 2.4.1. For chassis without bodywork
- 2.4.1.1. Length <sup>(g5)</sup>: .....

- 2.4.1.1.1. Maximum permissible length:.....
- 2.4.1.1.2. Minimum permissible length:.....
- 2.4.1.1.3. In the case of trailers, maximum permissible drawbar length (<sup>g6</sup>): .....
- 2.4.1.2. Width (<sup>g7</sup>):.....
- 2.4.1.2.1. Maximum permissible width:.....
- 2.4.1.2.2. Minimum permissible width: .....
- 2.4.1.3. Height (<sup>g8</sup>) (for suspensions adjustable for height, indicate normal running position):.....
- 2.4.1.4. Front overhang (<sup>g9</sup>): .....
- 2.4.1.4.1. Approach angle (<sup>g10</sup>) (<sup>4</sup>): .....degrees.
- 2.4.1.5. Rear overhang (<sup>g11</sup>):.....
- 2.4.1.5.1. Departure angle (<sup>g12</sup>) (<sup>4</sup>): .....degrees.
- 2.4.1.5.2. Minimum and maximum permissible overhang of the coupling point (<sup>g13</sup>):.....
- 2.4.1.6. Ground clearance (as defined in points 3.1.1 and 3.2.1 of Appendix 1 to Annex II to Directive 2007/46/EC)
- 2.4.1.6.1. Between the axles:.....
- 2.4.1.6.2. Under the front axle(s): .....
- 2.4.1.6.3. Under the rear axle(s):.....
- 2.4.1.8. Position of the centre of gravity of the bodywork and/or interior fittings and/or equipment and/or pay-mass (minimum and maximum):.....
- 2.4.2. For chassis with bodywork
- 2.4.2.1. Length (<sup>g5</sup>): .....
- 2.4.2.1.1. Length of the loading area:.....
- 2.4.2.2. Width (<sup>g7</sup>):.....
- 2.4.2.2.1. Thickness of the walls (in the case of vehicles designed for controlled-temperature carriage of goods):.....
- 2.4.2.3. Height (<sup>g8</sup>) (for suspensions adjustable for height, indicate normal running position):.....
- 2.4.2.4. Front overhang (<sup>g9</sup>): .....

- 2.4.2.4.1. Approach angle (<sup>g10</sup>) (<sup>4</sup>): ..... degrees.
- 2.4.2.5. Rear overhang (<sup>g11</sup>):.....
- 2.4.2.5.1. Departure angle (<sup>g12</sup>) (<sup>4</sup>): ..... degrees.
- 2.4.2.5.2. Minimum and maximum permissible overhang of the coupling point (<sup>g13</sup>):.....
- 2.4.2.6. Ground clearance (as defined in points 3.1.1 and 3.2.1 of Appendix 1 to Annex II to Directive 2007/46/EC) (<sup>4</sup>)
  - 2.4.2.6.1. Between the axles:.....
  - 2.4.2.6.2. Under the front axle(s): .....
  - 2.4.2.6.3. Under the rear axle(s): .....
- 2.4.2.8. Positions of the centre of gravity of the pay-mass (in the case of non-uniform load):.....
- 2.4.3. For bodywork approved without chassis (vehicles M2 and M3)
  - 2.4.3.1. Length (<sup>g5</sup>): .....
  - 2.4.3.2. Width (<sup>g7</sup>):.....
  - 2.4.3.3. Height (<sup>g8</sup>) on intended chassis type(s) (for suspensions adjustable for height, indicate normal running position): .....
- 2.5. Minimum mass on the steering axle(s) for incomplete vehicles:.....**
- 2.6. Mass in running order (<sup>h</sup>)**
  - (a) minimum and maximum for each variant:.....
  - 2.6.1. Distribution of this mass among the axles and, in the case of a semi-trailer, centre-axle trailer or rigid drawbar trailer, the mass on the coupling point : ....
    - (a) minimum and maximum for each variant:.....
  - 2.6.2. Mass of the optional equipment (see definition No 5 of Article 2 of Regulation (EU) No xxx/2012 [.....*this Regulation* - to be filled in by OPOCE] ) : .....
- 2.8. Technically permissible maximum laden mass (<sup>i</sup>) : .....**
  - 2.8.1. Distribution of this mass among the axles and, in the case of a semi-trailer, centre-axle trailer or rigid drawbar trailer, load on the coupling point : .....
- 2.9. Technically permissible maximum mass on each axle:.....**
- 2.10. Technically permissible maximum mass on each group of axles:.....**

**2.11. Technically permissible maximum towable mass of the towing vehicle**  
in case of:

2.11.1. Drawbar trailer: .....

2.11.2. Semi-trailer: .....

2.11.3. Centre-axle trailer: .....

2.11.4. Rigid drawbar trailer: .....

2.11.4.1. Maximum ratio of the coupling overhang (<sup>j</sup>) to the wheel base: .....

2.11.4.2. Maximum V-value: ..... kN.

2.11.5. Technically permissible maximum laden mass of the combination : .....

2.11.6. Maximum mass of unbraked trailer: .....

**2.12. Technically permissible maximum mass at the coupling point:**

2.12.1. of a towing vehicle: .....

2.12.2. of a semi-trailer, a centre-axle trailer or a rigid drawbar trailer: .....

2.12.3. Maximum permissible mass of the coupling device (if not fitted by the manufacturer): .....

**2.16. Intended registration/in service maximum permissible masses (optional)**

2.16.1. Registration/in service maximum permissible laden mass (<sup>5</sup>): .....

2.16.2. Registration/in service maximum permissible mass on each axle and, in the case of a semi-trailer or centre-axle trailer, intended load on the coupling point stated by the manufacturer if lower than the technically permissible maximum mass on the coupling point (<sup>5</sup>): .....

2.16.3. Registration/in service maximum permissible mass on each group of axles (<sup>5</sup>):  
.....

2.16.4. Registration/in service maximum permissible towable mass (<sup>5</sup>): .....

2.16.5. Registration/in service maximum permissible mass of the combination (<sup>5</sup>): ....

**3. POWER PLANT (<sup>k</sup>)**

**3.1. Manufacturer of the engine: .....**

**3.2. Internal combustion engine**

3.2.1.8. Maximum net power <sup>(n)</sup>: .....kW at .....min<sup>-1</sup> (manufacturer's declared value)  
Note: for the purposes of this Regulation, it is permitted to refer to the engine that shows the lowest power)

**3.3. Electric motor**

3.3.1.1. Maximum hourly output: .....kW

**3.4. Engine or motor combination**

3.4.1. Hybrid electric vehicle: yes/no <sup>(1)</sup>

3.4.5.4. Maximum power: .....kW

**4. TRANSMISSION <sup>(p)</sup>**

4.1. Drawing of the transmission <sup>(4)</sup>: .....

**5. AXLES**

5.1. Description of each axle: .....

5.2. Make: .....

5.3. Type: .....

5.4. Position of lift axle(s): .....

5.5. Position of loadable axle(s): .....

**6. SUSPENSION**

6.1. Drawing of the suspension arrangements: .....

6.2. Type and design of the suspension of each axle or group of axles or wheel: ...

6.2.3. Air-suspension for driving axle(s): yes/no <sup>(1)</sup>

6.2.3.1. Suspension of driving axle(s) equivalent to air-suspension: yes/no <sup>(1)</sup>

6.2.3.2. Frequency and damping of the oscillation of the sprung mass: .....

6.2.4. Air-suspension for non-driving axle(s): yes/no <sup>(1)</sup>

6.2.4.1. Suspension of non-driving axle(s) equivalent to air-suspension: yes/no <sup>(1)</sup>

6.2.4.2. Frequency and damping of the oscillation of the sprung mass: .....

- 6.3. Distribution of the mass between the axles which are part of a group of axles (where necessary, provide appropriate graphs) : .....
- 6.6. Tyres and wheels
  - 6.6.1. Tyre/wheel combination(s) (†)
    - (a) for tyres indicate
      - (i) size designation: ....  
.....
      - (ii) load-capacity index: ..... .....
      - (iii) speed category symbol:..... .....
  - 6.6.1.1. Axles
    - 6.6.1.1.1. Axle 1: .....
    - 6.6.1.1.2. Axle 2: .....
    - etc.
- 9. BODYWORK**
  - 9.1. Type of bodywork using the codes defined in Part C of Annex II:.....
  - 9.10.3. Seats
    - 9.10.3.1. Number of seating positions (⁸): .....
    - 9.10.3.1.1. Location and arrangement: .....
    - 9.10.3.5. Coordinates or drawing of the R-point (†)
      - 9.10.3.5.1. Driver's seat: .....
      - 9.10.3.5.2. All other seating positions: .....
  - 9.25. Devices designed to reduce aerodynamic drag
    - 9.25.1. Drawing and description of the device
- 11. CONNECTIONS BETWEEN TOWING VEHICLES AND TRAILERS AND SEMI-TRAILERS**
  - 11.1. Class and type of the coupling device(s) fitted or to be fitted:.....



11.2. Characteristics D, U, S and V of the coupling device(s) fitted or minimal characteristics D, U, S and V of the coupling device(s) to be fitted: ..... daN

**13. SPECIAL PROVISIONS FOR BUSES AND COACHES**

13.1. Class of vehicle: Class I/Class II/Class III/Class A/Class B (<sup>1</sup>)

13.2. Area for passengers (m<sup>2</sup>)

13.2.1. Total (S<sub>0</sub>): .....

13.2.2. Upper deck (S<sub>0a</sub>) (<sup>1</sup>): .....

13.2.3. Lower deck (S<sub>0b</sub>) (<sup>1</sup>): .....

13.2.4. For standing passengers (S<sub>1</sub>): .....

13.3. Number of passengers (seated and standing)

13.3.1. Total (N): .....

13.3.2. Upper deck (N<sub>a</sub>) (<sup>1</sup>): .....

13.3.3. Lower deck (N<sub>b</sub>) (<sup>1</sup>): .....

13.4. Number of passengers seated

13.4.1. Total (A): .....

13.4.2. Upper deck (A<sub>a</sub>) (<sup>1</sup>): .....

13.4.3. Lower deck (A<sub>b</sub>) (<sup>1</sup>): .....

13.4.4. Number of wheelchair positions for category M<sub>2</sub> and M<sub>3</sub> vehicles: .....

13.7. Volume of luggage compartments (m<sup>3</sup>): .....

13.12. Drawing with dimensions showing the interior arrangement as regards the seating positions, area for standees, wheelchair user(s), luggage compartments including racks and ski-box, if any

### Explanatory notes

- (<sup>1</sup>) Delete where not applicable (there are cases where nothing needs to be deleted when more than one entry is applicable).
- (<sup>4</sup>) Only for the purpose of definition of off-road vehicles.
- (<sup>5</sup>) Set out in such a way as to make the actual value clear for each technical configuration of the vehicle type.
- (<sup>7</sup>) Optional equipment that affects the dimensions of the vehicle shall be specified.

- 
- (<sup>b</sup>) If the means of identification of type contains characters not relevant to describe the vehicle, component or separate technical unit types covered by this information document, such characters shall be represented in the documentation by the symbol "?" (e.g. ABC??123??).
  - (<sup>c</sup>) Classified according to the definitions set out in Part A of Annex II.
  - (<sup>c</sup>) "Forward control" as defined in Point 2.7. of Annex I to Council Directive 74/297/EEC <sup>20</sup>.
  - (<sup>f</sup>) Where there is one version with a normal cab and another with a sleeper cab, both sets of masses and dimensions are to be stated
  - (<sup>g</sup>) Standard ISO 612 : 1978 – Road vehicles – Dimensions of motor vehicles and towed vehicles – terms and definitions.
  - (<sup>g1</sup>) - term No 6.4.
  - (<sup>g2</sup>) - term No 6.19.2.
  - (<sup>g3</sup>) - term No 6.20.
  - (<sup>g4</sup>) - term No 6.5.
  - (<sup>g5</sup>) - term No 6.1 and for vehicles other than those of category M<sub>1</sub>.  
  
In the case of trailers, the lengths shall be specified as mentioned in term No 6.1.2. of Standard ISO 612 : 1978.
  - (<sup>g6</sup>) - term No 6.17.
  - (<sup>g7</sup>) - term No 6.2 and for vehicles other than those of category M<sub>1</sub>.
  - (<sup>g8</sup>) - term No 6.3 and for vehicles other than those of category M<sub>1</sub>.
  - (<sup>g9</sup>) - term No 6.6.
  - (<sup>g10</sup>) - term No 6.10.

---

<sup>20</sup> OJ L 165, 20.6.1974, p. 16.

(<sup>g11</sup>) - term No 6.7.

(<sup>g12</sup>) - term No 6.11.

(<sup>g13</sup>) - term No 6.18.1.

(<sup>g14</sup>) - term No 6.9.

(<sup>h</sup>) The mass of the driver is assessed at 75 kg.

The liquid containing systems (except those for used water that must remain empty) are filled to 100 % of the capacity specified by the manufacturer.

The information referred to in points 2.6. (b) and 2.6.1.(b) do not need to be provided for vehicle categories N<sub>2</sub>, N<sub>3</sub>, M<sub>2</sub>, M<sub>3</sub>, O<sub>3</sub>, and O<sub>4</sub>.

(<sup>i</sup>) For trailers or semi-trailers, and for vehicles coupled with a trailer or a semi-trailer, which exert a significant vertical load on the coupling device or the fifth wheel, this load, divided by standard acceleration of gravity, is included in the maximum technically permissible mass.

(<sup>j</sup>) "Coupling overhang" is the horizontal distance between the coupling for centre-axle trailers and the centreline of the rear axle(s).

(<sup>k</sup>) In the case of a vehicle that can run either on petrol, diesel, etc., or also in combination with another fuel, items shall be repeated.

In the case of non-conventional engines and systems, particulars equivalent to those referred to here shall be supplied by the manufacturer.

(<sup>l</sup>) This figure shall be rounded off to the nearest tenth of a millimetre.

(<sup>n</sup>) Determined in accordance with the requirements of Council Directive 80/1269/EEC <sup>21</sup>.

(<sup>o</sup>) Determined in accordance with the requirements of Council Directive 80/1268/EEC <sup>22</sup>.

(<sup>p</sup>) The specified particulars are to be given for any proposed variants.

(<sup>r</sup>) For tyres of category Z intended to be fitted on vehicles whose maximum speed exceeds 300 km/h equivalent information shall be provided.

(<sup>s</sup>) The number of seating positions to be mentioned shall be the one when the vehicle is in motion. A range can be specified in case of modular arrangement.

(<sup>t</sup>) "R-point" or "seating reference point" means a design point defined by the vehicle manufacturer for each seating position and established with respect to the three-dimensional reference system as specified in Annex III to Directive 77/649/EEC <sup>23</sup>.

---

<sup>21</sup> OJ L 375, 31.12.1980, p.46.

<sup>22</sup> OJ L 375, 31.12.1980, p.36.

<sup>23</sup> OJ L 267, 19.10.1977, p.1.

**PART B**

**EC type-approval certificate**

MODEL

Format: A4 (210 × 297 mm)

**EC TYPE-APPROVAL CERTIFICATE**

Stamp of type-approval authority

Communication concerning:

- EC type-approval <sup>(1)</sup>
  - extension of EC type-approval <sup>(1)</sup>
  - refusal of EC type-approval <sup>(1)</sup>
  - withdrawal of EC type-approval <sup>(1)</sup>
- } of a type of vehicle with regard to its masses and dimensions

with regard to Regulation (EU) No. .../...,

EC type-approval number:

Reason for extension:

#### SECTION I

- 0.1. Make (trade name of manufacturer):
- 0.2. Type:
  - 0.2.1. Commercial name(s) (if available):
- 0.4. Category of vehicle (<sup>2</sup>):
- 0.5. Company name and address of manufacturer:
- 0.8. Name(s) and address(es) of assembly plant(s):
- 0.9. Name and address of the manufacturer's representative (if any):

## SECTION II

1. Additional information (where applicable): see Addendum
2. Technical service responsible for carrying out the tests:
3. Date of test report:
4. Number of test report:
5. Remarks (if any):
6. Place:
7. Date:
8. Signature:

<u>Attachments:</u>	(1)	Information package (all pages must bear the stamp of the type-approval authority).
	(2)	Test report.
	(3)	For vehicles fitted with a suspension that is recognised to be equivalent to air suspension, the test report and the technical description of the suspension.

### *Addendum* to EC type-approval certificate No ...

#### **Remarks**

1. The vehicle has been type-approved in accordance with Article 6(1) of this Regulation (i.e. the outermost dimensions of the vehicle exceeds the maximum dimensions mentioned in Part A, B, C or D of Annex I): ..... yes/no <sup>(1)</sup>
- 2.. The vehicle is fitted with air-suspensions: ..... yes/no <sup>(1)</sup>
3. The vehicle is fitted with a suspension recognised to be equivalent to air-suspension: ..... yes/no <sup>(1)</sup>
4. The vehicle fulfils the requirements for off-road vehicle: ..... yes/no <sup>(1)</sup>

Legend:

- (<sup>1</sup>) Delete where not applicable
- (<sup>2</sup>) As defined in Annex II, Section A.

## ANNEX VI

### Amendments to Annexes I, III, IX, and XVI to Directive 2007/46/EC

Directive 2007/46/EC is amended as follows:

(1) Annex I is amended as follows:

(a) Point 0.5 is replaced by the following:

‘0.5 Company name and address of manufacturer: .....’

(b) Point 1.9 is replaced by the following:

‘1.9. Specify if the towing vehicle is intended to tow semi-trailers or other trailers and, if the trailer is a semi-, drawbar-, centre-axle- or rigid drawbar trailer:.....’

(c) The following point 1.10 is added:

‘1.10. Specify if the vehicle is specially designed for the controlled-temperature carriage of goods: .....’

(d) Point 2. is replaced by the following:

‘2. MASSES AND DIMENSIONS <sup>(f)</sup> <sup>(g)</sup> <sup>(7)</sup>  
(in kg and mm) (Refer to drawing where applicable)’

(e) Points 2.1.1.1, 2.1.1.1.1 and 2.1.1.1.2 are replaced by the following:

‘2.1.2. Vehicles with three or more axles

2.1.2.1. Axle spacing between consecutive axles going from the foremost to the rearmost axle: .....

2.1.2.2. Total axle spacing: .....’

(f) Points 2.5 and 2.5.1 are replaced by the following:

‘2.5. **Minimum mass on the steering axle(s) for incomplete vehicles:** .....’

(g) Points 2.6. and 2.6.1. are replaced by the following:

‘2.6. **Mass in running order <sup>(h)</sup>**

(a) minimum and maximum for each variant: .....

(b) mass of each version (a matrix must be provided): .....’

2.6.1. Distribution of this mass among the axles and, in the case of a semi-trailer, a centre-axle trailer or a rigid drawbar trailer, the



mass on the coupling point: .....

(a) minimum and maximum for each variant: .....

(b) mass of each version (a matrix must be provided): .....

(h) The following point 2.6.2. is inserted to read:

‘2.6.2. Mass of the optional equipment (see the definition set out in point (5) of Article 2 of Commission Regulation (EU) No xxx/2012 [[.....this Regulation to be filled in by OPOCE](#)]:.....’

(i) Point 2.10 is replaced by the following:

**‘2.10. Technically permissible mass on each group of axles:.....’**

(j) Point 2.11 is replaced by the following:

**‘2.11 Technically permissible maximum towable mass of the towing vehicle**  
in case of:’

(k) Point 2.11.4. is replaced by the following:

‘2.11.4. Rigid drawbar trailer: .....

(l) Point 2.11.5 is replaced by the following:

‘2.11.5 Technically permissible maximum laden mass of the combination <sup>(3)</sup>:.....’

(m) Points 2.12, 2.12.1 and 2.12.2 are replaced by the following:

**‘2.12. Technically permissible maximum mass at the coupling point:**

2.12.1. of a towing vehicle: .....

2.12.2. of a semi-trailer, a centre-axle trailer or a rigid drawbar trailer: .....

(n) Points 2.16 to 2.16.5 are replaced by the following:

**‘2.16. Registration/in service maximum permissible masses (optional)**

2.16.1. Registration/in service maximum permissible laden mass:.....

2.16.2. Registration/in service maximum permissible mass on each axle and, in the case of a semi-trailer or centre-axle trailer, intended

load on the coupling point stated by the manufacturer if lower than the technically permissible maximum mass on the coupling point:.....

2.16.3. Registration/in service maximum permissible mass on each group of axles: .....

2.16.4. Registration/in service maximum permissible towable mass:.....

2.16.5. Registration/in service maximum permissible mass of the combination:.....’

(o) The following point 13.12 is added:

‘13.12. Drawing with dimensions showing the interior arrangement as regards the seating positions, area for standees, wheelchair user(s), luggage compartments including racks and ski-box, if any’

(p) The explanatory notes are amended as follows:

(i) The following note (7) is inserted:

‘(7) Optional equipment that affects the dimensions of the vehicle shall be specified.’

(ii) Note (h) is replaced by the following:

‘(h) The mass of the driver is assessed at 75 kg.

The liquid containing systems (except those for used water that must remain empty) are filled to 100 % of the capacity specified by the manufacturer.

The information referred to in points 2.6. (b) and 2.6.1.(b) do not need to be provided for vehicle categories N<sub>2</sub>, N<sub>3</sub>, M<sub>2</sub>, M<sub>3</sub>, O<sub>3</sub>, and O<sub>4</sub>.’

(2) Part I of Annex III is amended as follows:

(a) Section A is amended as follows:

(i) Point 0.5 is replaced by the following:

‘0.5 Company name and address of manufacturer: .....’

(ii) The following points 1.9. and 1.10 are added :

‘1.9. Specify if the towing vehicle is intended to tow semi-trailers or other trailers and, if the trailer is a semi-, drawbar-, centre-axle-

or rigid drawbar trailer:.....

1.10. Specify if the vehicle is specially designed for the controlled-temperature carriage of goods:.....’

(iii) Point 2. is replaced by the following:

‘**2. MASSES AND DIMENSIONS** <sup>(f)</sup> <sup>(g)</sup> <sup>(7)</sup>  
(in kg and mm) (Refer to drawing where applicable)’

(iv) The following point 2.5 is inserted:

‘**2.5. Minimum mass on the steering axle(s) for incomplete vehicles:**.....’

(v) Point 2.6. and 2.6.1. are replaced by the following:

‘**2.6. Mass in running order** <sup>(h)</sup>

(a) minimum and maximum for each variant: .....

(b) mass of each version (a matrix must be provided): .....

2.6.1. Distribution of this mass among the axles and, in the case of a semi-trailer a rigid drawbar trailer or a centre-axle trailer, the mass on the coupling: .....

(a) minimum and maximum for each variant: .....

(b) mass of each version (a matrix must be provided): .....

(vi) The following point 2.6.2. is inserted:

‘2.6.2. Mass of the optional equipment (as defined in point (5) of Article 2 of Commission Regulation (EU) No xxx/2012 [*.....this Regulation to be filled in by OPOCE*]): .....

(vii) Point 2.10 is replaced by the following:

‘**2.10. Technically permissible mass on each group of axles:**.....’

(viii) Point 2.11 is replaced by the following:

‘**2.11 Technically permissible maximum towable mass of the towing vehicle**

in case of:’

(ix) Point 2.11.4. is replaced by the following:

‘2.11.4. Rigid drawbar trailer: .....

(x) Point 2.11.5 is replaced by the following:

‘2.11.5 Technically permissible maximum laden mass of the combination <sup>(3)</sup>:.....’

(xi) Points 2.12, 2.12.1. and 2.12.2 are replaced by the following:

‘**2.12. Technically permissible maximum mass at the coupling point:**

2.12.1. of a towing vehicle: .....

2.12.2. of a semi-trailer, a centre-axle trailer or a rigid drawbar trailer: .....

(xii) Points 2.16 to 2.16.5 are replaced by the following:

‘**2.16. Registration/in service maximum permissible masses (optional)**

2.16.1. Registration/in service maximum permissible laden mass:.....

2.16.2. Registration/in service maximum permissible mass on each axle and, in the case of a semi-trailer or centre-axle trailer, intended load on the coupling point stated by the manufacturer if lower than the technically permissible maximum mass on the coupling point:.....

2.16.3. Registration/in service maximum permissible mass on each group of axles: .....

2.16.4. Registration/in service maximum permissible towable mass:.....

2.16.5. Registration/in service maximum permissible mass of the combination:.....’

(b) Section B is amended as follows:

(i) Point 0.5 is replaced by the following:

‘0.5 Company name and address of manufacturer: .....

(ii) The following points 1.9. and 1.10 are added:

‘1.9. Specify if the towing vehicle is intended to tow semi-trailers or other trailers and, if the trailer is a semi-, drawbar-, centre-axle- or rigid drawbar trailer:.....

1.10. Specify if the vehicle is specially designed for the controlled-temperature carriage of goods:.....’

(iii) Point 2. is replaced by the following:

**‘2. MASSES AND DIMENSIONS <sup>(f)</sup> <sup>(g)</sup> <sup>(7)</sup>**  
(in kg and mm) (Refer to drawing where applicable)’

(iv) Point 2.6. and 2.6.1. are replaced by the following:

**‘2.6. Mass in running order <sup>(h)</sup>**

(a) minimum and maximum for each variant: .....

(b) mass of each version (a matrix must be provided): .....

2.6.1. Distribution of this mass among the axles and, in the case of a semi-trailer a rigid drawbar trailer or a centre-axle trailer, the mass on the coupling: .....

(a) minimum and maximum for each variant: .....

(b) mass of each version (a matrix must be provided): .....

(v) The following point 2.6.2. is inserted:

‘2.6.2. Mass of the optional equipment (as defined in point (5) of Article 2 of Commission Regulation (EU) No xxx/2012 [*.....this Regulation to be filled in by OPOCE*]): .....

(vi) Point 2.10 is replaced by the following:

**‘2.10. Technically permissible mass on each group of axles:.....’**

(vii) Points 2.12 and 2.12.2 are replaced by the following:

**‘2.12. Technically permissible maximum mass at the coupling point:**

2.12.2. of a semi-trailer, a centre-axle trailer or a rigid drawbar trailer: .....

(viii) Points 2.16 to 2.16.3 are replaced by the following:

**‘2.16. Registration/in service maximum permissible masses (optional)**

2.16.1. Registration/in service maximum permissible laden mass:.....

2.16.2. Registration/in service maximum permissible mass on each axle and, in the case of a semi-trailer or centre-axle trailer, intended load on the coupling point stated by the manufacturer if lower than the technically permissible maximum mass on the coupling point:.....

2.16.3. Registration/in service maximum permissible mass on each group

of axles:.....’

- (ix) Point 2.16.5 is deleted

3. Annex IX is amended as follows:

- (a) In “Model A1 - Side 1 – Complete vehicles - EC Certificate of Conformity”, entry 0.5 is replaced by the following:  
‘0.5 Company name and address of manufacturer: .....’
- (b) In “Model A2 - Side 1 – Complete vehicles type-approved in small series – [Year] – [Sequential number] - EC Certificate of Conformity”, entry 0.5 is replaced by the following:  
‘0.5 Company name and address of manufacturer: .....’
- (c) In “Model B - Side 1 – Completed vehicles - EC Certificate of Conformity”, entry 0.5 is replaced by the following:  
‘0.5 Company name and address of manufacturer: .....’
- (d) In “Model C1 - Side 1 – Incomplete vehicles - EC Certificate of Conformity”, entry 0.5 is replaced by the following:  
‘0.5 Company name and address of manufacturer: .....’
- (e) In “Model C2 - Side 1 – Incomplete vehicles type-approved in small series – [Year] – [Sequential number] - EC Certificate of Conformity”, entry 0.5 is replaced by the following:  
‘0.5 Company name and address of manufacturer: .....’
- (f) In “Side 2 – Vehicle category M<sub>1</sub> (complete and completed vehicles)” entry 13 is replaced by the following:  
‘13. Mass in running order: ...kg ’
- (g) In “Side 2 – Vehicle category M<sub>1</sub> (complete and completed vehicles)”, the following entry 13.2 is inserted:  
‘13.2. Actual mass of the vehicle: .....kg’
- (h) In “Side 2 – Vehicle category M<sub>2</sub> (complete and completed vehicles)”, entry 13 is replaced by the following:  
‘13. Mass in running order: ...kg ’
- (i) In “Side 2 – Vehicle category M<sub>2</sub> (complete and completed vehicles)”, the following entry 13.2. is inserted:

- ‘13.2. Actual mass of the vehicle: .....kg’
- (j) In “Side 2 – Vehicle category M<sub>3</sub> (complete and completed vehicles)”, entry 13 is replaced by the following:
- ‘13. Mass in running order: ...kg ’
- (k) In “Side 2 – Vehicle category M<sub>3</sub> (complete and completed vehicles)”, the following entry 13.2. is inserted:
- ‘13.2. Actual mass of the vehicle: .....kg’
- (l) In “Side 2 – Vehicle category N<sub>1</sub> (complete and completed vehicles)”, entry 13 is replaced by the following:
- ‘13. Mass in running order: ...kg ’
- (m) In “Side 2 – Vehicle category N<sub>1</sub> (complete and completed vehicles)”, the following entry 13.2. is inserted:
- ‘13.2. Actual mass of the vehicle: .....kg’
- (n) In “Side 2 – Vehicle category N<sub>2</sub> (complete and completed vehicles)”, entry 13. is replaced by the following:
- ‘13. Mass in running order: ...kg ’
- (o) In “Side 2 – Vehicle category N<sub>2</sub> (complete and completed vehicles)”, the following entry 13.2 is inserted:
- ‘13.2. Actual mass of the vehicle: .....kg’
- (p) In “Side 2 – Vehicle category N<sub>3</sub> (complete and completed vehicles)”, entry 13. is replaced by the following:
- ‘13. Mass in running order: ...kg ’
- (q) In “Side 2 – Vehicle category N<sub>3</sub> (complete and completed vehicles)”, the following entry 13.2 is inserted:
- ‘13.2. Actual mass of the vehicle: .....kg’
- (r) In “Side 2 – Vehicle category O<sub>1</sub> and O<sub>2</sub> (complete and completed vehicles)”, entry 13. is replaced by the following:
- ‘13. Mass in running order: ...kg ’
- (s) In “Side 2 – Vehicle category O<sub>1</sub> and O<sub>2</sub> (complete and completed vehicles)”, the following entry 13.2. is inserted:
- ‘13.2. Actual mass of the vehicle: .....kg’

- (t) In “Side 2 – Vehicle category O<sub>3</sub> and O<sub>4</sub> (complete and completed vehicles)”, entry 13. is replaced by the following:  
‘13.            Mass in running order: ...kg ’
- (u) In “Side 2 – Vehicle category M<sub>1</sub> (incomplete vehicles)”, the following entry 13.2. is inserted:  
‘13.            Mass in running order: ...kg’
- (v) In “Side 2 – Vehicle category M<sub>1</sub> (incomplete vehicles)”, entry 14. is replaced by the following:  
‘14            Actual mass of the vehicle: ...kg ’
- (w) In “Side 2 – Vehicle category M<sub>2</sub> (incomplete vehicles)”, entry 14. is replaced by the following:  
‘14            Actual mass of the vehicle: ...kg ’
- (x) In “Side 2 – Vehicle category M<sub>3</sub> (complete and completed vehicles)”, entry 14. is replaced by the following:  
‘14            Actual mass of the vehicle: ...kg ’
- (y) In “Side 2 – Vehicle category N<sub>1</sub> (incomplete vehicles)”, entry 13. is inserted:  
‘13.            Mass in running order: ...kg’
- (z) In “Side 2 – Vehicle category N<sub>1</sub> (incomplete vehicles)”, entry 14. is replaced by the following:  
‘14            Actual mass of the vehicle: ...kg ’
- (aa) In “Side 2 – Vehicle category N<sub>2</sub> (incomplete vehicles)”, entry 14. is replaced by the following:  
‘14            Actual mass of the vehicle: ...kg ’
- (ab) In “Side 2 – Vehicle category N<sub>3</sub> (incomplete vehicles)”, entry 14. is replaced by the following:  
‘14            Actual mass of the vehicle: ...kg ’
- (ac) In “Side 2 – Vehicle category O<sub>1</sub> and O<sub>2</sub> (incomplete vehicles)”, entry 14. is replaced by the following:  
‘14            Actual mass of the vehicle: ...kg ’
- (ad) In “Side 2 – Vehicle category O<sub>3</sub> and O<sub>4</sub> (incomplete vehicles)”, entry 14. is replaced by the following:



‘14 Actual mass of the vehicle: ...kg ’

(ae) In the ‘Explanatory notes relating to Annex IX’, note (f) is deleted.

4. Annex XVI is amended as follows:

(a) The following entry 44 is inserted in the list of regulatory acts:

‘44 Commission Regulation (EU) No xxx/2012 [*.....this Regulation to be filled in by OPOCE*]

(b) The following entry 44 is inserted in Appendix 2

	Regulatory act reference	Annex and paragraph	Specific conditions
‘44	Commission Regulation (EU) No xxx/2012 [ <i>.....this Regulation to be filled in by OPOCE</i> ]	Sections 7 and 8 of Part B of Annex I	(a) Check of compliance with the manoeuvrability requirements including manoeuvrability of vehicles fitted with lift- or loadable axles.
		Sections 6 and 7 of Part C of Annex I	(b) Measurement of the maximum rear swing-out.’

## ANNEX VII

### 'ANNEX XII

#### SMALL SERIES AND END-OF-SERIES LIMITS

##### A. SMALL SERIES LIMITS

1. The number of units of one type of vehicle to be registered, sold or put into service per year in the Community pursuant to Article 22 may not exceed the figures shown below for the vehicle category in question:

Category	Units
M <sub>1</sub>	1,000
M <sub>2</sub> , M <sub>3</sub>	0
N <sub>1</sub>	0
N <sub>2</sub> , N <sub>3</sub>	0
O <sub>1</sub> , O <sub>2</sub>	0
O <sub>3</sub> , O <sub>4</sub>	0

2. The number of units of one type of vehicle to be registered, sold or put into service per year in one Member State pursuant to Article 23 shall be determined by that Member State but shall not exceed the figures shown below for the vehicle category in question:

Category	Units
M <sub>1</sub>	75
M <sub>2</sub> , M <sub>3</sub>	250
N <sub>1</sub>	500
N <sub>2</sub> , N <sub>3</sub>	250
O <sub>1</sub> , O <sub>2</sub>	500
O <sub>3</sub> , O <sub>4</sub>	250

3. The number of units of one type of vehicle to be registered, sold or put into service per year in one Member State for the purposes of Article 6(2) of Commission Regulation (EU) No xxx/2012 [*...this Regulation – to be filled in by OPOCE*] shall be determined by each Member State but shall not exceed the figures shown below for the vehicle category in question:

Category	Units
M <sub>2</sub> , M <sub>3</sub>	1,000
N <sub>2</sub> , N <sub>3</sub>	1,200
O <sub>3</sub> , O <sub>4</sub>	2,000

## B. END-OF-SERIES LIMITS

The maximum number of complete and completed vehicles put into service in each Member State under the procedure "End-of-Series" shall be restricted in one of the following ways to be chosen by the Member State:

1. the maximum number of vehicles of one or more types may not exceed 10 %, in the case of category M1, and may not exceed 30 % of the vehicles of all types concerned put into service in that Member State during the previous year, in the case of all other categories.

Should 10 %, respectively 30 %, be less than 100 vehicles, then the Member State may allow the putting into service of a maximum of 100 vehicles.

2. vehicles of any one type shall be restricted to those for which a valid certificate of conformity was issued on or after the date of manufacture and which remained valid for at least three months after its date of issue but subsequently lost its validity due to the entry into force of a regulatory act.'