



**COUNCIL OF
THE EUROPEAN UNION**

Brussels, 13 November 2012

16152/12

TRANS 393

COVER NOTE

from: European Commission
date of receipt: 9 November 2012
to: General Secretariat of the Council

No Cion doc.: D020665/02

Subject: COMMISSION REGULATION (EU) No .../.. of XXX concerning the technical specification for interoperability relating to the subsystem 'rolling stock — freight wagons' of the rail system in the European Union and repealing Commission Decision 2006/861/EC

Delegations will find attached Commission document D020665/02.

Encl.: D020665/02



EUROPEAN COMMISSION

Brussels, **XXX**
[...](2012) **XXX** draft

COMMISSION REGULATION (EU) No .../..

of **XXX**

**concerning the technical specification for interoperability relating to the subsystem
'rolling stock — freight wagons' of the rail system in the European Union and repealing
Commission Decision 2006/861/EC**

(Text with EEA relevance)

COMMISSION REGULATION (EU) No .../..

of XXX

concerning the technical specification for interoperability relating to the subsystem 'rolling stock — freight wagons' of the rail system in the European Union and repealing Commission Decision 2006/861/EC

(Text with EEA relevance)

THE EUROPEAN COMMISSION,

Having regard to the Treaty on the Functioning of the European Union,

Having regard to Directive 2008/57/EC of the European Parliament and of the Council of 17 June 2008 on the interoperability of the rail system within the Community,¹ and in particular Article 6(1) second subparagraph thereof,

Whereas:

- (1) Article 12 of Regulation (EC) No 881/2004 of the European Parliament and of the Council of 29 April 2004 establishing a European Railway Agency² requires the European Railway Agency (the Agency) to ensure that the technical specifications for interoperability (TSIs) are adapted to technical progress, market trends and social requirements and to propose to the Commission the amendments to the TSIs which it considers necessary.
- (2) With Decision C(2010) 2576 of 29 April 2010, the Commission gave the Agency a mandate to develop and review the technical specifications for interoperability with a view to extending their scope to the European Union's entire rail system. Under the terms of that mandate, the Agency was asked to extend the scope of the Technical Specification for Interoperability relating to the subsystem 'rolling stock – freight wagons' to the European Union's entire rail system.
- (3) On 1 February 2012 the European Railway Agency submitted a recommendation on the revised Technical Specification for Interoperability ('TSI') relating to the subsystem 'rolling stock – freight wagons'.
- (4) The TSI on rolling stock should not impose the use of specific technologies or technical solutions except where this is strictly necessary for the interoperability of the European Union's rail system.

¹ OJ L 191, 18.7.2008, p. 1.

² OJ L 164, 30.4.2004, p. 1.

- (5) The TSI on rolling stock which is to be established by this Regulation does not cover all the essential requirements set out in Annex III of Directive 2008/57/EC. In accordance with Article 5(6) of Directive 2008/57/EC, the technical aspects that are not covered should be identified as open points.
- (6) In accordance with Article 17(3) of Directive 2008/57/EC, Member States are to notify to the Commission and other Member States the technical rules, the conformity assessment and verification procedures to be used in specific cases, and the bodies responsible for carrying out these procedures.
- (7) The TSI on 'rolling stock – wagons' should refer to Commission Decision 2010/713/EU of 9 November 2010 on modules for the procedures for assessment of conformity, suitability for use and EC verification to be used in the technical specifications for interoperability adopted under Directive 2008/57/EC of the European Parliament and of the Council³.
- (8) In accordance with Article 11(5) of Directive 2008/57/EC, the TSI on rolling stock should allow, for a limited period of time, interoperability constituents to be incorporated into subsystems without certification, provided that certain conditions are met.
- (9) Decision 2006/861/EC of 28 July 2006 concerning the technical specification of interoperability relating to the subsystem rolling stock — freight wagons of the trans-European conventional rail system⁴ should therefore be repealed.
- (10) The measures provided for in this Regulation are in accordance with the opinion of the Committee established in accordance with Article 29(1) of Directive 2008/57/EC,

HAS ADOPTED THIS REGULATION:

Article 1

The technical specification for interoperability (TSI) relating to the 'rolling stock – freight wagons' subsystem of the entire European Union's rail system, as set out in Annex I, is hereby adopted.

Article 2

1. The TSI shall apply to the 'rolling stock – freight wagons' subsystem as described in point 2.7 of Annex II to Directive 2008/57/EC.
2. The TSI shall apply to freight wagons with a maximum operating speed lower than or equal to 160 km/h and a maximum axle load lower than or equal to 25 t.
3. The TSI shall apply to freight wagons which are intended to be operated on one or more of the following nominal track gauges: 1435 mm, 1524 mm, 1600 mm, and

³ OJ L 319, 4.12.2010, p.1.

⁴ OJ L 344, 8.12.2006, p. 1.

1668 mm. The TSI shall not apply to freight wagons operating mainly on the 1520 mm track gauge, which may occasionally be operated on 1524 mm track gauge.

Article 3

The TSI shall apply to all new freight wagon rolling stock of the European Union's rail system, taking into account Section 7 of the Annex.

The TSI set out in the Annex shall also apply to existing freight wagon rolling stock:

- (a) when it is renewed or upgraded in accordance with Article 20 of Directive 2008/57/EC, or
- (b) with regard to specific provisions, such as the traceability of axles in point 4.2.3.6.4 and the maintenance plan in point 4.5.3.

The detailed technical scope of this Regulation is set out in Chapter 2 of the Annex.

Article 4

1. With regard to 'open points' set out in Appendix A of the TSI, the conditions to be complied with for the verification of interoperability pursuant to Article 17(2) of Directive 2008/57/EC shall be the applicable technical rules in use in the Member State which authorise the placing in service of the subsystem covered by this Regulation.
2. Within six months of the entry into force of this Regulation, each Member State shall send the other Member States and the Commission the following information, provided it has not already been sent to them under Commission Decision 2006/861/EC:
 - (a) the list of the applicable technical rules referred to in paragraph 1;
 - (b) the conformity assessment and verification procedures to be carried out to apply those rules;
 - (c) the bodies appointed to carry out those conformity-assessment and verification procedures.

Article 5

1. With regard to specific cases set out in Chapter 7 of the TSI, the conditions to be met for the verification of interoperability pursuant to Article 17(2) of Directive 2008/57/EC shall be the applicable technical rules in use in the Member State which authorise the placing in service of the subsystems covered by this Regulation.
2. Within six months of the entry into force of this Regulation, each Member State shall notify to the other Member States and to the Commission:
 - (a) the applicable technical rules referred to in paragraph 1;

- (b) the conformity assessment and verification procedures to be carried out to apply the technical rules referred to in paragraph 1;
- (c) the bodies appointed to carry out the conformity assessment and verification procedures of the specific cases referred to in paragraph 1.

Article 6

1. Without prejudice to the agreements which have already been notified under Commission Decision 2006/861/EC and shall not be notified again, Member States shall notify the Commission, within six months of the entry into force of this Regulation, any national, bilateral, multilateral or international agreements under which freight wagons, falling under the scope of this Regulation, are operated.
2. Member States shall forthwith notify the Commission any future agreements or modifications of existing agreements.

Article 7

In accordance with Article 9(3) of Directive 2008/57/EC, within one year of the entry into force of this Regulation, each Member State shall communicate to the Commission a list of projects being implemented within its territory and that are at an advanced stage of development.

Article 8

1. An EC certificate of verification for a subsystem that contains interoperability constituents which do not have an EC declaration of conformity or suitability for use may be issued during a transition period of ten years after the entry into force of this Regulation, provided the provisions set out in Section 6.3 of the Annex are met.
2. The production or upgrade/renewal of the subsystem using non-certified interoperability constituents shall be completed within the transition period set out in paragraph 1, including placing in service.
3. During the transition period set out in paragraph 1:
 - (a) the reasons for non-certification of any interoperability constituents shall be properly identified in the verification procedure referred to in paragraph 1;
 - (b) the national safety authorities shall report on the use of non-certified interoperability constituents in the context of authorisation procedures in their annual report referred to in Article 18 of Directive 2004/49/EC of the European Parliament and of the Council⁵.
4. After a transition period of one year after the entry into force of this Regulation, newly produced interoperability constituents, which are not covered by the

⁵ OJ L 164, 30.4.2004, p.44.

exceptions set out in Section 6.5 of the Annex, shall be covered by the required EC declaration of conformity and/or suitability for use.

Article 9

The declaration of verification and/or conformity to type of a new vehicle established in accordance with Decision 2006/861/EC shall be considered valid until the end of a transition period of three years after the entry into force of this Regulation.

Article 10

1. The Agency shall publish on its website the lists of fully approved composite brake blocks for international transport referred to in Appendix G.
2. The Agency shall keep the list referred to in paragraph 1 up to date and inform the Commission of any changes to it. The Commission shall inform the Member States of any changes to the list through the Committee established in accordance with Article 29 of Directive 2008/57/EC.

Article 11

Decision 2006/861/EC is repealed with effect from 1 January 2014.

It shall continue to apply, however, to the maintenance of projects authorised in accordance with that Decision and, unless the applicant requests to apply this Regulation, to projects for new, renewed or upgraded subsystems which are at an advanced stage of development or are the subject of a contract which is being carried out on the date this Regulation is published.

Article 12

This Regulation shall enter into force on the day following that of its publication in the Official Journal of the European Union.

It shall apply from 1 January 2014. However, an authorisation for placing into service may be granted in application of the TSI as set out in the Annex to this Regulation, except its section 7.1.2, before 1 January 2014.

This Regulation shall be binding in its entirety and directly applicable in all Member States.

Done at Brussels,

For the Commission
The President
José Manuel BARROSO

ANNEX

Technical Specification for Interoperability for the 'rolling stock – wagon' subsystem

TABLE OF CONTENTS

| | | |
|------------|---|----|
| 1. | Introduction..... | 12 |
| 1.1. | Technical scope..... | 12 |
| 1.2. | Geographical scope..... | 12 |
| 1.3. | Content of this TSI..... | 12 |
| 2. | Scope and definition of subsystem..... | 13 |
| 3. | Essential requirements | 13 |
| 4. | Characterisation of the subsystem..... | 16 |
| 4.1. | Introduction..... | 16 |
| 4.2. | Functional and technical specifications of the subsystem..... | 17 |
| 4.2.1. | General..... | 17 |
| 4.2.2. | Structures and mechanical part | 18 |
| 4.2.2.1. | Mechanical Interface..... | 18 |
| 4.2.2.1.1. | End coupling | 18 |
| 4.2.2.1.2. | Inner coupling | 18 |
| 4.2.2.2. | Strength of unit..... | 18 |
| 4.2.2.3. | Integrity of the unit..... | 18 |
| 4.2.3. | Gauging and track interaction | 18 |
| 4.2.3.1. | Gauging..... | 18 |
| 4.2.3.2. | Compatibility with load carrying capacity of lines..... | 19 |
| 4.2.3.3. | Compatibility with train detection systems..... | 19 |
| 4.2.3.4. | Axle bearing condition monitoring | 19 |
| 4.2.3.5. | Running safety | 20 |
| 4.2.3.5.1. | Safety against derailment running on twisted track | 20 |
| 4.2.3.5.2. | Running dynamic behaviour | 20 |
| 4.2.3.6. | Running gear | 20 |
| 4.2.3.6.1. | Structural design of bogie frame | 21 |
| 4.2.3.6.2. | Characteristics of wheelsets | 21 |

| | |
|---|----|
| 4.2.3.6.3. Characteristics of wheels..... | 22 |
| 4.2.3.6.4. Characteristics of axles..... | 24 |
| 4.2.3.6.5. Axle boxes / bearings | 24 |
| 4.2.3.6.6. Variable gauge wheelsets | 24 |
| 4.2.3.6.7. Running gear for manual change of wheelsets..... | 25 |
| 4.2.4. Brake | 25 |
| 4.2.4.1. General | 25 |
| 4.2.4.2. Safety requirements..... | 26 |
| 4.2.4.3. Functional and technical requirements..... | 26 |
| 4.2.4.3.1. General functional requirements | 26 |
| 4.2.4.3.2. Brake performance | 26 |
| 4.2.4.3.2.1. Service brake | 26 |
| 4.2.4.3.2.2. Parking brake..... | 27 |
| 4.2.4.3.3. Thermal capacity | 27 |
| 4.2.4.3.4. Wheel slide protection (WSP)..... | 27 |
| 4.2.5. Environmental conditions | 28 |
| 4.2.6. System protection..... | 29 |
| 4.2.6.1. Fire safety..... | 29 |
| 4.2.6.1.1. General | 29 |
| 4.2.6.1.2. Functional and technical specification | 29 |
| 4.2.6.1.2.1. Barriers | 29 |
| 4.2.6.1.2.2. Materials..... | 29 |
| 4.2.6.1.2.3. Cables..... | 30 |
| 4.2.6.1.2.4. Flammable liquids | 30 |
| 4.2.6.2. Protection against electrical hazards | 30 |
| 4.2.6.2.1. Protective measures against indirect contact (protective bonding)..... | 30 |
| 4.2.6.2.2. Protective measures against direct contact..... | 30 |
| 4.2.6.3. Attachment devices for rear-end signal..... | 30 |
| 4.3. Functional and technical specification of the interfaces | 30 |
| 4.3.1. Interface with the subsystem “infrastructure” | 30 |
| 4.3.2. Interface with the subsystem “operation and traffic management” | 31 |

| | | |
|----------|--|----|
| 4.3.3. | Interface with the subsystem “control, command and signalling” | 32 |
| 4.4. | Operating rules | 32 |
| 4.5. | Maintenance rules | 33 |
| 4.5.1. | General documentation | 33 |
| 4.5.2. | Maintenance design justification file | 33 |
| 4.5.3. | Maintenance description file | 34 |
| 4.6. | Professional competencies | 35 |
| 4.7. | Health and safety conditions | 35 |
| 4.8. | Parameters to be recorded in the technical file | 36 |
| 5. | Interoperability constituents..... | 37 |
| 5.1. | General | 37 |
| 5.2. | Innovative solutions | 37 |
| 5.3. | Interoperability constituent specifications | 37 |
| 5.3.1. | Running gear | 37 |
| 5.3.2. | Wheelset..... | 38 |
| 5.3.3. | Wheel | 38 |
| 5.3.4. | Axle | 38 |
| 5.3.5. | Rear-end signal..... | 38 |
| 6. | Conformity assessment and EC verification | 39 |
| 6.1. | Interoperability constituent | 39 |
| 6.1.1. | Modules..... | 39 |
| 6.1.2. | Conformity Assessment procedures..... | 39 |
| 6.1.2.1. | Running gear | 40 |
| 6.1.2.2. | Wheelset..... | 40 |
| 6.1.2.3. | Wheel | 41 |
| 6.1.2.4. | Axle | 41 |
| 6.1.3. | Innovative solutions for Interoperability Constituents..... | 42 |
| 6.2. | Subsystem | 42 |
| 6.2.1. | Modules..... | 42 |
| 6.2.2. | EC verification procedures..... | 42 |
| 6.2.2.1. | Strength of unit..... | 43 |

| | | |
|------------|---|----|
| 6.2.2.2. | Safety against derailment running on twisted track | 43 |
| 6.2.2.3. | Running dynamic behaviour | 43 |
| 6.2.2.4. | Axle box / bearings | 44 |
| 6.2.2.5. | Running gear for manual change of wheelsets | 44 |
| 6.2.2.6. | Thermal capacity | 44 |
| 6.2.2.7. | Environmental conditions | 44 |
| 6.2.2.8. | Fire safety | 44 |
| 6.2.2.8.1. | Barriers | 44 |
| 6.2.2.8.2. | Materials | 45 |
| 6.2.2.8.3 | Cables | 45 |
| 6.2.2.8.4 | Flammable liquids | 45 |
| 6.2.3. | Innovative solutions | 45 |
| 6.3. | Subsystem containing interoperability constituents not holding an EC declaration.. | 45 |
| 6.4. | Project phases where assessment is required | 46 |
| 6.5. | Constituents holding an EC declaration of conformity | 46 |
| 7. | Implementation | 47 |
| 7.1. | Authorisation for placing in service | 47 |
| 7.1.1. | Authorisation for placing into service of a new vehicle in conformity with previous WAG TSIs | 47 |
| 7.1.2. | Mutual recognition of the first authorisation of placing in service | 47 |
| 7.2. | Substitution, renewal and upgrading | 48 |
| 7.3. | Specific cases | 50 |
| 7.3.1. | Introduction | 50 |
| 7.3.2. | List of specific cases | 50 |
| 7.3.2.1. | General specific cases | 50 |
| 7.3.2.2. | Axle bearing condition monitoring (point 4.2.3.4) | 50 |
| 7.3.2.3. | Safety against derailment running on twisted track (point 4.2.3.5.1) | 51 |
| 7.3.2.4. | Running dynamic behaviour (point 4.2.3.5.2) | 51 |
| 7.3.2.5. | Characteristics of wheelsets (point 4.2.3.6.2) | 51 |
| 7.3.2.6. | Characteristics of wheels (point 4.2.3.6.3) | 51 |
| 7.3.2.7. | Attachments devices for rear end signals (point 4.2.6.3) | 52 |

| | | |
|------|---|----|
| 7.4. | Specific environmental conditions..... | 52 |
| 7.5. | Freight wagons operating under national, bilateral, multilateral or international agreements..... | 52 |
| | Appendices..... | 55 |

1. INTRODUCTION

A Technical Specification for Interoperability (TSI) is a specification that covers a subsystem (or part of it) as described in Article 2(i) of Directive 2008/57/EC in order:

- to ensure the interoperability of the rail system and
- to meet the essential requirements.

1.1. Technical scope

See Article 2.

1.2. Geographical scope

The geographical scope of this TSI is the entire European Union's rail system as set out in Article 1, taking into account the limitations concerning the track gauge set out in Article 2.

1.3. Content of this TSI

In accordance with Article 5(3) of Directive 2008/57/EC, this TSI:

- (a) indicates its intended scope (Chapter 2);
- (b) lays down essential requirements for the part of the rolling stock subsystem concerned and for its interfaces vis-à-vis other subsystems (Chapter 3);
- (c) establishes the functional and technical specifications to be met by the subsystem and its interfaces vis-à-vis other subsystems (Chapter 4).
- (d) determines the interoperability constituents and interfaces which must be covered by European specifications, including European standards, which are necessary to achieve interoperability within the rail system (Chapter 5);
- (e) states, in each case under consideration, which procedures are to be used in order to assess the conformity or the suitability for use of the interoperability constituents and the 'EC' verification of the subsystems (Chapter 6);
- (f) indicates the strategy for implementing the TSIs (Chapter 7);
- (g) indicates, for the staff concerned, the professional qualifications and health and safety conditions at work that are required for the operation and maintenance of the above subsystem, as well as for the implementation of this TSI (Chapter 4).

2. SCOPE AND DEFINITION OF SUBSYSTEM

This TSI is applicable to “freight wagons including vehicles designed to carry lorries” as referred to in Annex I section 1.2 of Directive 2008/57/EC taking into account the limitations as set out in Article 2. In the following this part of the subsystem rolling stock is called “freight wagon” and belongs to the subsystem “rolling stock” as set out in Annex II to Directive 2008/57/EC.

The other vehicles listed in point 1.2 of Annex I to Directive 2008/57/EC are excluded from the scope of this TSI; this is especially the case for mobile railway infrastructure construction and maintenance equipment and vehicles designed to carry

- motor vehicles with their passengers on board or
- motor vehicles without passengers on board but intended to be integrated in passenger trains (car carriers).

In the present TSI the following definitions are used:

(a) A **unit** is the generic term used to name the rolling stock. It is subject to the application of this TSI, and therefore subject to the EC verification procedure.

A unit can consist of:

- a **wagon** that can be operated separately, featuring an individual frame mounted on its own set of wheels or
- a rake of permanently connected **elements**, those elements cannot be operated separately or
- **separate rail bogies connected to compatible road vehicle(s)** the combination of which forms a rake of a rail compatible system.

(b) A **train** is an operational formation consisting of several units.

(c) The **design operating state** covers all conditions under which the unit is intended to operate and its technical boundaries. This design operating state may go beyond the specifications of this TSI in order that units may be used together in a train on the network under the safety management system of a railway undertaking.

3. ESSENTIAL REQUIREMENTS

Article 4(1) of Directive 2008/57/EC states, that the rail system its subsystems and their interoperability constituents shall meet the relevant essential requirements. The essential requirements are set out in general terms in Annex III of Directive 2008/57/EC. Table 1 indicates the basic parameters specified in this TSI and their correspondence to the essential requirements as explained in Annex III to Directive 2008/57/EC.

Table 1

Basic parameters and their correspondence to the essential requirements

| point | basic parameter | essential requirements | | | | |
|-----------|--|-------------------------------------|----------------------------|--------|------------------------|-------------------------|
| | | safety | reliability & availability | health | environment protection | technical compatibility |
| 4.2.2.1.1 | End coupling | 1.1.1, 1.1.3, 1.1.5, 2.4.1 | | | | |
| 4.2.2.1.2 | Inner coupling | 1.1.1, 1.1.3, 2.4.1 | | | | |
| 4.2.2.2 | Strength of unit | 1.1.1, 1.1.3, 2.4.1 | | | | |
| 4.2.2.3 | Integrity of the unit | 1.1.1 | | | | |
| 4.2.3.1 | Gauging | 1.1.1 | | | | 2.4.3 |
| 4.2.3.2 | Compatibility with load carrying capacity of lines | 1.1.1 | | | | 2.4.3 |
| 4.2.3.3 | Compatibility with train detection systems | 1.1.1 | | | | 2.4.3 |
| 4.2.3.4 | Axle bearing condition monitoring | 1.1.1 | 1.2 | | | 2.4.3 |
| 4.2.3.5.1 | Safety against derailment running on twisted track | 1.1.1, 1.1.2, 2.4.1 | | | | 2.4.3 |
| 4.2.3.5.2 | Running dynamic behaviour | 1.1.1 1.1.2 | | | | 2.4.3 |

| | | | | | | |
|-------------|---|---------------------------|--------------|--|--|-------|
| 4.2.3.6.1 | Structural design of bogie frame | 1.1.1, 1.1.2, 1.1.3 | | | | |
| 4.2.3.6.2 | Characteristics of wheelsets | 1.1.1, 1.1.2, 1.1.3 | | | | 2.4.3 |
| 4.2.3.6.3 | Characteristics of wheels | 1.1.1, 1.1.2, 1.1.3 | | | | 2.4.3 |
| 4.2.3.6.4 | Characteristics of axles | 1.1.1, 1.1.2, 1.1.3 | | | | |
| 4.2.3.6.5 | Axle box / bearings | 1.1.1, 1.1.2, 1.1.3 | | | | |
| 4.2.3.6.6 | Variable gauge wheelsets | 1.1.1, 1.1.2, 1.1.3 | | | | |
| 4.2.3.6.7 | Running gear for manual change of wheelsets | 1.1.1, 1.1.2, 1.1.3 | | | | |
| 4.2.4.2 | Brake - Safety requirements | 1.1.1, 1.1.3 | 1.2 2.4.2 | | | |
| 4.2.4.3.1 | Brake - General functional requirements | 1.1.1 2.4.1 | 2.4.2 | | | |
| 4.2.4.3.2.1 | Brake performance – In-service brake | 1.1.1, 1.1.2 2.4.1 | 2.4.2 | | | 1.5 |
| 4.2.4.3.2.2 | Brake performance – Parking brake | 2.4.1 | | | | 2.4.3 |
| 4.2.4.3.3 | Brake - Thermal capacity | 1.1.1, 1.1.3 2.4.1 | | | | 2.4.3 |
| 4.2.4.3.4 | Brake - Wheel slide protection (WSP) | 2.4.1 | 2.4.2 | | | |

| | | | | | | |
|-------------|---------------------------------------|----------------|--|-------|-------|-------|
| 4.2.5 | Environ-mental conditions | 1.1.1 1.1.2 | | | | 2.4.3 |
| 4.2.6.1 | Fire safety General | 1.1.1 1.1.4 | | | | |
| 4.2.6.1.2.1 | Fire safety Barriers | 1.1.4 | | 1.3.2 | 1.4.2 | |
| 4.2.6.1.2.2 | Fire safety Materials | 1.1.4 | | 1.3.2 | 1.4.2 | |
| 4.2.6.1.2.3 | Fire safety Cables | 1.1.4 1.1.5 | | 1.3.2 | 1.4.2 | |
| 4.2.6.1.2.4 | Fire safety – Flammable liquids | 1.1.4 | | 1.3.2 | 1.4.2 | |
| 4.2.6.2 | Protection against electric hazard | 1.1.5 2.4.1 | | | | |
| 4.2.6.3 | Attachment device for rear-end signal | 1.1.1 | | | | |

The essential requirements 1.3.1, 1.4.1, 1.4.3, 1.4.4 and 1.4.5 of Annex III to Directive 2008/57/EC fall under the scope of other Union legislation.

4. CHARACTERISATION OF THE SUBSYSTEM

4.1. Introduction

The rail system, to which Directive 2008/57/EC applies and of which freight wagons form a part, is an integrated system whose consistency shall be verified. This consistency shall be checked in particular with regard to the specifications of the rolling stock subsystem and the compatibility with the network (section 4.2), its interfaces in relation to the other subsystems of the rail system in which it is integrated (sections 4.2 and 4.3), as well as the initial operating and maintenance rules (section 4.4 and 4.5) as requested by Article 18(3) of Directive 2008/57/EC.

The technical file, as set out in Article 18(3) and Annex VI to Directive 2008/57/EC (section 4.8), shall contain in particular design related values concerning the compatibility with the network.

4.2. Functional and technical specifications of the subsystem

4.2.1. General

In light of the essential requirements in Chapter 3, the functional and technical specifications of the subsystem “rolling stock - freight wagons” are grouped and sorted out in the following points of this Chapter:

- Structures and mechanical parts
- Gauging and vehicle track interaction
- Brake
- Environmental conditions
- System protection

Except where this is strictly necessary for the interoperability of the rail system and to meet the relevant essential requirements, the functional and technical specifications of the freight wagon and its interfaces do not impose the use of any particular technical solutions.

Innovative solutions, which do not fulfil the requirements specified in this TSI and/or which are not assessable as stated in this TSI, require new specifications and / or new assessment methods. In order to allow technological innovation, these specifications and assessment methods shall be developed by the process “innovative solution” described in Chapter 6.

When the functional and technical specifications that are necessary in order to achieve interoperability and to meet the essential requirements, have not been developed concerning a particular technical aspect, this aspect is identified as an open point in the relevant point. As required in Article 5(6) of Directive 2008/57/EC all open points are listed in Appendix A.

In Appendix C a set of conditions is specified. The conformity with this set of conditions is optional. If this option is selected, the conformity shall be assessed by a notified body within the EC verification procedure.

In accordance with Article 5(5) of Directive 2008/57/EC, provision may be made for specific cases for each TSI. Such provisions are indicated in Chapter 7.

As far as possible the assessment procedure for the requirements in section 4.2 is defined in Chapter 6. In these cases the text of section 4.2 makes a reference to the corresponding points and sub points clauses of Chapter 6. If for a particular basic parameter the separation of requirements and assessment procedures is not feasible, no reference is given.

4.2.2. *Structures and mechanical parts*

4.2.2.1. Mechanical Interface

4.2.2.1.1. End coupling

The end coupling is the mechanical interface between units forming a train.

The coupling system shall be designed in a way that no human presence between the units to be coupled / uncoupled shall be required whilst either one unit is moving.

End couplings shall be resilient and capable of withstanding the forces in accordance with the defined design operating state of the unit.

4.2.2.1.2. Inner coupling

The inner coupling is the mechanical interface between elements forming a unit.

The inner coupling shall be resilient and capable of withstanding the forces in accordance with the defined design operating state of the unit. The joint between two elements sharing the same running gear, is covered by point 4.2.2.2.

The longitudinal strength of the inner coupling(s) shall be equal to or higher than the one of the end coupling(s) of the unit.

4.2.2.2. Strength of unit

The structure of a unit body, any equipment attachments and lifting and jacking points shall be designed such that no cracks, no significant permanent deformation or ruptures occur under the load cases defined in Chapter 5 of EN12663-2:2010. Joining techniques shall be deemed to be covered by the demonstration of conformity in accordance to point 6.2.2.1.

The demonstration of conformity is described in point 6.2.2.1.

The jacking positions shall be marked on the unit. The marking shall comply with point 4.5.13 of EN15877-1:2012.

4.2.2.3. Integrity of the unit

The unit shall be designed so that all movable parts intended to close an aperture (access doors, tarpaulin, lids, hatches, etc.) are prevented against an unintentional movement of these parts.

Locking devices shall indicate their status (open/closed) and shall be visible outside the unit.

4.2.3. *Gauging and track interaction*

4.2.3.1. Gauging

This point concerns the rules for calculation intended for sizing the rolling stock to run on one or several networks without interference risk.

The compliance of a unit with the intended reference profile including the reference profile for the lower part shall be established by one of the methods set out in EN 15273-2:2009.

The kinematic method, as described in EN 15273-2:2009 shall be used to establish conformity, if any, between the reference profile established for the unit and the respective target reference profiles G1, GA, GB and GC including those used for the lower part GIC1 and GIC2.

4.2.3.2. Compatibility with load carrying capacity of lines

The vertical loading characteristics of the unit shall be determined in order to check compatibility with the load carrying capacity of lines.

The permissible payload a unit may carry, for axle loads up to and including 25t, shall be determined by application of clauses 6.1 and 6.2 of EN 15528:2008.

4.2.3.3. Compatibility with train detection systems

If the unit is intended to be compatible with one or more of the following train detection systems, this compatibility shall be established according to the provisions of the Commission Decision 2012/88/EU⁶.

- (a) Train detection systems based on track circuits.
- (b) Train detection systems based on axle counters.
- (c) Train detection systems based on loop equipment.

4.2.3.4. Axle bearing condition monitoring

It shall be possible to monitor the axle bearing condition either by

- line side detection equipment or
- on-board equipment.

If the unit is intended to be capable of being monitored by line side equipment on the 1435 mm track gauge network the unit shall be compliant with clauses 5.1 and 5.2 of EN 15437-1:2009 in order to ensure sufficient visibility.

For units intended to be operated on the networks with track gauges of 1524 mm, 1600 mm, 1668 mm, the corresponding values in table 2 referring to the parameters of the standard EN 15437-1:2009 shall be applied.

⁶ OJ L 51, 23.2.2012, p. 1.

Table 2

Target and prohibitive zone for units intended to be operated on particular networks

| | Y_{TA} [mm] | W_{TA} [mm] | L_{TA} [mm] | Y_{PZ} [mm] | W_{PZ} [mm] | L_{PZ} [mm] |
|--------------------------------------|---------------|---------------|---------------|---------------|---------------|---------------|
| 1524 mm (both areas are relevant) | 1080±35 | ≥50 | ≥200 | 1080±5 | ≥140 | ≥500 |
| | 894±2 | ≥14 | ≥200 | 894±2 | ≥28 | ≥500 |
| 1600 mm | 1110±2 | ≥70 | ≥180 | 1110±2 | ≥125 | ≥500 |
| 1668 mm | 1176±10 | ≥55 | ≥100 | 1176±10 | ≥110 | ≥500 |

The specifications of the design and the conformity assessment of on-board equipment is an open point in this TSI.

4.2.3.5. Running safety

The dynamic behaviour of a vehicle has a strong influence on safety against derailment, running safety and track loading.

4.2.3.5.1. Safety against derailment running on twisted track

The unit shall be designed to ensure safe running on twisted track, taking into account specifically the transition phase between canted and level track and cross level deviations.

The demonstration of conformity is described in point 6.2.2.2.

4.2.3.5.2. Running dynamic behaviour

The unit shall be designed to provide safe movement up to the maximum design speed.

The running dynamic behaviour of a unit shall be proven either by

- following the procedures set out in Chapter 5 of EN 14363:2005, or
- performing simulations using a validated model.

The demonstration of conformity is described in point 6.2.2.3.

For units equipped with running gear assessed on interoperability constituent level in accordance with point 6.1.2.1, a specific test or simulation on subsystem level is not required.

4.2.3.6. Running gear

The running gear guarantees to carry and guide the unit safely as well as to transmit braking forces where so required.

4.2.3.6.1. Structural design of bogie frame

The integrity of the structure of a bogie frame, all attached equipment and body to bogie connection shall be demonstrated based on methods as set out in point 6.2 of EN 13749:2011.

The demonstration of conformity is described in point 6.1.2.1.

4.2.3.6.2. Characteristics of wheelsets

The wheelset assembly shall be able to transmit forces and torque between the fitted parts in accordance with the area of use.

The geometric dimensions of the wheelsets, as defined in figure 1, shall be compliant with limit values specified in table 3. These limit values shall be taken as design values and shall be stated as in-service limit values in the maintenance file described in section 4.5.

The demonstration of conformity is described in point 6.1.2.2.

Fig. 1

Symbols for wheelsets used in table 3

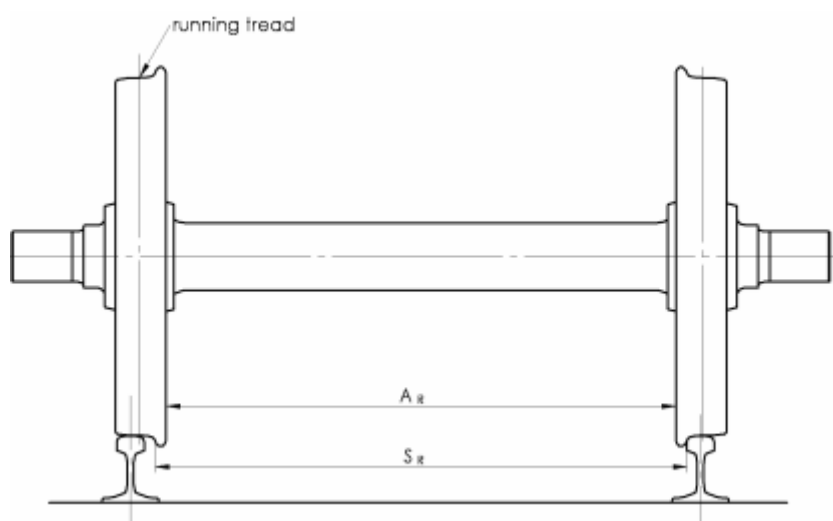

Table 3

Limits of use of the geometric dimensions of wheelsets

| Designation | | Wheel diam. D [mm] | Minimum value [mm] | Maximum value [mm] |
|-------------|--|-----------------------|-----------------------|-----------------------|
| 1435 mm | Front-to-front dimension (S_R) $S_R = A_R + S_{d,left} + S_{d,right}$ | $330 \leq D \leq 760$ | 1415 | 1426 |
| | | $760 < D \leq 840$ | 1412 | 1426 |
| | | $D > 840$ | 1410 | 1426 |

| | | | | |
|---------|--|------------------------|-------------------|------|
| | Back to back distance (A_R) | $330 \leq D \leq 760$ | 1359 | 1363 |
| | | $760 < D \leq 840$ | 1358 | 1363 |
| | | $D > 840$ | 1357 | 1363 |
| 1524 mm | Front-to-front dimension (S_R) $S_R = A_R + S_{d, \text{left}} + S_{d, \text{right}}$ | $400 \leq D < 840$ | 1492 | 1514 |
| | | $D \geq 840$ | 1487 | 1514 |
| | Back to back distance (A_R) | $400 \leq D < 840$ | 1444 | 1448 |
| | | $D \geq 840$ | 1442 | 1448 |
| 1600 mm | Front-to-front dimension (S_R) $S_R = A_R + S_{d, \text{left}} + S_{d, \text{right}}$ | $690 \leq D \leq 1016$ | 1573 | 1592 |
| | | | | |
| | Back to back distance (A_R) | $690 \leq D \leq 1016$ | 1521 | 1526 |
| | | | | |
| 1668 mm | Front-to-front dimension (S_R) $S_R = A_R + S_{d, \text{left}} + S_{d, \text{right}}$ | $330 \leq D < 840$ | 1648 ⁷ | 1659 |
| | | $840 \leq D \leq 1250$ | 1643 ⁸ | 1659 |
| | Back to back distance (A_R) | $330 \leq D < 840$ | 1592 | 1596 |
| | | $840 \leq D \leq 1250$ | 1590 | 1596 |

4.2.3.6.3. Characteristics of wheels

The geometrical dimensions of the wheels as defined in Figure 2 shall be compliant with limit values specified in table 4.

Table 4

Limits of use of the geometric dimensions of wheels

| Designation | | Wheel diam. D [mm] | Minimum value [mm] | Maximum value [mm] |
|-------------|--|-----------------------|-----------------------|-----------------------|
| 1435 | Width of the rim (B_R) (with maximum BURR of 5 mm) | $D \geq 330$ | 133 | 140 |
| | Thickness of the flange (S_d) | $330 \leq D \leq 760$ | 27,5 | 33 |

⁷ Two-axle wagons with axle load up to 22.5t the value shall be taken as 1651 mm

⁸ Two-axle wagons with axle load up to 22.5t the value shall be taken as 1651 mm

| | | | | |
|------------------------------|--|------------------------|------------------|-----|
| | | $760 < D \leq 840$ | 25 | 33 |
| | | $D > 840$ | 22 | 33 |
| | Height of the flange (S_h) | $330 \leq D \leq 630$ | 31,5 | 36 |
| | | $630 < D \leq 760$ | 29,5 | 36 |
| | | $D > 760$ | 27,5 | 36 |
| Face of the flange (q_R) | $D \geq 330$ | 6,5 | - | |
| 1524 mm | Width of the rim (B_R) (with maximum BURR of 5 mm) | $D \geq 400$ | 134 | 140 |
| | Thickness of the flange (S_d) | $400 \leq D < 760$ | 27,5 | 33 |
| | | $760 \leq D < 840$ | 25 | 33 |
| | | $D \geq 840$ | 22 | 33 |
| | Height of the flange (S_h) | $400 \leq D < 630$ | 31,5 | 36 |
| | | $630 \leq D < 760$ | 29,5 | 36 |
| | | $D \geq 760$ | 27,5 | 36 |
| Face of the flange (q_R) | $D \geq 400$ | 6,5 | - | |
| 1600 mm | Width of the rim (B_R) (with maximum BURR of 5 mm) | $690 \leq D \leq 1016$ | 137 | 139 |
| | Thickness of the flange (S_d) | $690 \leq D \leq 1016$ | 26 | 33 |
| | Height of the flange (S_h) | $690 \leq D \leq 1016$ | 28 | 38 |
| | Face of the flange (q_R) | $690 \leq D \leq 1016$ | 6,5 | - |
| 1668 mm | Width of the rim (B_R) (with maximum BURR of 5 mm) | $D \geq 330$ | 133 | 140 |
| | Thickness of the flange (S_d) | $330 \leq D \leq 840$ | 27,5 | 33 |
| | | $D > 840$ | 22 (PT); 25 (ES) | 33 |
| | Height of the flange (S_h) | $330 \leq D \leq 630$ | 31,5 | 36 |
| | | $630 \leq D \leq 760$ | 29,5 | 36 |
| | | $D > 760$ | 27,5 | 36 |
| Face of the flange (q_R) | $D \geq 330$ | 6,5 | - | |

These limit values shall be taken as design values and shall be stated as in-service limit values in the maintenance file described in section 4.5.

Fig. 2

Symbols for wheels used in table 4

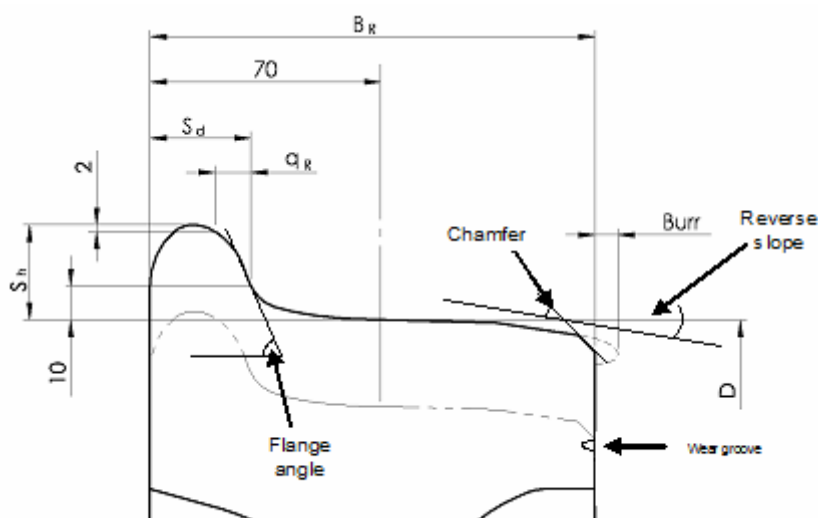

The mechanical characteristics of the wheels shall ensure the transmission of forces and torque as well as the resistance against thermal load where so required in accordance with the area of use.

The demonstration of conformity is described in point 6.1.2.3.

4.2.3.6.4. Characteristics of axles

The characteristics of the axle shall ensure the transmission of forces and torque in accordance with the area of use.

The demonstration of conformity is described in point 6.1.2.4.

The traceability of axles shall take into accounts the findings of the ERA Task force on Freight Maintenance (see “*Final report on the activities of the Task Force Freight Wagon Maintenance*” published on the ERA website <http://www.era.europa.eu>).

4.2.3.6.5. Axle boxes / bearings

The axle box and the rolling bearing shall be designed with consideration of mechanical resistance and fatigue characteristics. Temperature limits reached in service relevant for the hot box detection shall be defined.

The demonstration of conformity is described in point 6.2.2.4.

4.2.3.6.6. Variable gauge wheelsets

This requirement is applicable to units equipped with variable gauge wheelsets with changeover between two track gauges.

The changeover mechanism of the wheelset shall ensure the safe locking

- of the wheels and

- of the corresponding brake equipment

in the correct intended axial position considering the dynamic effects in accordance with the design operating state of the unit.

The conformity assessment of the requirements specified in this point is an open point.

4.2.3.6.7. Running gear for manual change of wheelsets

The requirement is applicable to units prepared to run on different track gauges, by means of a physical change of wheelset.

The unit shall be equipped with a locking mechanism in order to ensure the correct position of its brake equipment in the different configurations considering the dynamic effects in accordance with the design operating state of the unit.

The demonstration of conformity is described in point 6.2.2.5.

4.2.4. *Brake*

4.2.4.1. General

The purpose of the train brake system is to ensure that

- the train's speed can be reduced,
- the train's speed can be maintained on a slope
- the train can be stopped within the maximum allowable braking distance and that
- the train can be immobilised.

Primary factors that influence the braking performance and the braking process are

- the braking power,
- the train mass,
- the speed,
- the allowable braking distance,
- the available adhesion and
- the track gradient.

The brake performance of a train is derived from the individual brake performance of each unit in the train.

4.2.4.2. Safety requirements

The braking system contributes to the safety level of the railway system. Therefore the design of the braking system of a unit has to undergo a risk assessment in accordance with Commission Regulation (EC) No 352/2009⁹ considering the hazard of complete loss of the brake capability of the unit. The severity level shall be deemed as catastrophic when

- it affects the unit alone (combination of failures) or,
- it affects the brake capability of more than the unit (single fault).

The fulfilment of the conditions of C.9 and C.14 of Appendix C is presumed to be in conformity with this requirement.

4.2.4.3. Functional and technical requirements

4.2.4.3.1. General functional requirements

The brake equipment of the unit shall provide the functions of braking such as the application and the release of the brake, upon a transmitted signal. The brake shall be

- continuous (the brake application or release signal is transmitted from a central command to the whole train by a control line),
- automatic (an inadvertent disruption of the control line shall lead to brake activation on all units of the train bringing each part to stand still),
- disengageable, which enables its release and isolation.

4.2.4.3.2. Brake performance

4.2.4.3.2.1. Service brake

The brake performance of a train or a unit is its ability to decelerate. It is the result of the braking power available to decelerate the train or unit within defined limits and all factors involved in the conversion and dissipation of energy including train resistance.

The brake performance of a unit shall be calculated in accordance with one of the following documents:

- EN 14531-6:2009 or
- UIC 544-1:2012.

The calculation shall be validated by tests. Brake performance calculation in accordance with UIC 544-1 shall be validated as set out in UIC 544-1:2012.

⁹ OJ L 108, 29.04.2009, p.4.

4.2.4.3.2.2. Parking brake

A Parking Brake is a brake used to prevent parked rolling stock moving under the specified conditions taking into account the place, wind, gradient and rolling stock loading state, until intentionally released.

If the unit is equipped with a parking brake, the following requirements shall be met:

- the immobilisation shall remain until intentionally released.
- where it is not possible to identify the state of the parking brake directly, an indicator showing the state shall be provided on both sides on the outside of the vehicle.
- the minimum parking brake performance, considering no wind, shall be determined by calculations as defined in the standard clause 6 of EN 14531-6:2009.
- the minimum performance of the parking brake shall be marked on the unit. The marking shall comply with clause 4.5.25 of EN15877-1:2012. The parking brake of a unit shall be designed considering a wheel/rail (steel/steel) adhesion factor not higher than 0,12.

4.2.4.3.3. Thermal capacity

The brake equipment shall be able to withstand one emergency brake application without any loss of brake performance due to thermal or mechanical effects.

The braking power, the unit is capable to withstand without any adverse loss of brake performance due to thermal or mechanical effects, shall be defined and expressed in terms of speed and brake application time.

The demonstration of conformity is described in point 6.2.2.6.

A slope of 21 ‰ at 70 km/h during 40 km may be considered as the reference case for the thermal capacity which results in a braking power of 45 kW per wheel during 34 minutes for a nominal wheel diameter of 920 mm and an axle load of 22.5 t.

4.2.4.3.4. Wheel slide protection (WSP)

Wheel slide protection (WSP) is a system designed to use the maximum available adhesion by decreasing, holding or increasing the brake force to prevent wheel sets from locking and uncontrolled sliding. Thereby the stopping distance shall be optimized

If an electronic WSP-control is used negative effects caused by malfunctions of WSP shall be reduced by suitable system design processes and technical configuration.

The WSP shall not alter the functional characteristics of the brakes. The vehicle's air equipment shall be dimensioned such that the air consumption of the WSP does not impair the performance of the pneumatic brake. The design process of the WSP shall

take into account that the WSP has no detrimental effect on the constituent parts of the vehicle (brake gear, wheel tread, axle boxes, etc.).

The following types of units shall be fitted with WSP:

- Equipped with all types of brake block, for which the maximum mean utilisation of adhesion is greater than 0,12.
- Equipped with disc brakes only and/or with composite brake blocks, for which the maximum mean utilisation of adhesion is greater than 0,11.

4.2.5. *Environmental conditions*

The design of the unit, as well as its constituents shall take into account the environmental conditions to which this rolling stock will be subjected to.

The environmental parameters are described in the clauses below. For each environmental parameter, a nominal range is defined, which is the most commonly encountered in Europe, and is the basis for the interoperable unit.

For certain environmental parameters ranges other than the nominal one are defined. In that case, a range shall be selected for the design of the unit.

For the functions identified in the clauses below, design and/or testing provisions taken to ensure that the rolling stock is meeting the TSI requirements in this range shall be described in the technical file.

Depending on the ranges selected and on provisions taken (described in the technical file), appropriate operating rules could be necessary when the unit designed for the nominal range is operated on a particular line where the nominal range is exceeded at certain periods of the year.

The ranges, if different from the nominal one, to be selected to avoid any restrictive operating rule(s) linked to environmental conditions, are specified by the Member States and are listed in section 7.4.

The unit and its constituents shall be designed under consideration of one or several of the following temperature classes allocated to external air temperature ranges

- T1: -25°C to +40°C (nominal),
- T2: -40°C to +35°C and
- T3: -25°C to +45°C

The unit shall meet the requirements of this TSI without degradation for snow, ice and hail conditions as defined in clause 4.7 of EN 50125-1:1999, which correspond to the nominal range.

Where more severe ‘snow, ice and hail’ conditions than considered in the standard are selected, the unit and its constituents shall then be designed to meet TSI requirements considering the combined effect with low temperature according to the temperature range chosen.

In relation with the temperature range T2 and with the severe conditions for snow, ice and hail, the provisions taken to meet TSI requirements in these severe conditions shall be identified and verified, in particular design and/or testing provisions considering the following functions:

- Coupling function restricted to the resiliency of couplings.
- Brake function, including brake equipment.

The demonstration of conformity is described in point 6.2.2.7.

4.2.6. *System protection*

4.2.6.1. Fire safety

4.2.6.1.1. General

All significant potential fire sources (high risk components) on the unit shall be identified. The fire safety aspects of the unit design shall be aimed at

- preventing a fire from occurring,
- limiting the effects if a fire occurs.

The goods carried on the unit are not part of the unit and do not have to be taken into account in the conformity assessment.

4.2.6.1.2. Functional and technical specification

4.2.6.1.2.1. Barriers

In order to limit the effects of fire, fire barriers with integrity of at least 15 minutes shall be installed between the identified potential fire sources (high risk components) and the carried load.

The demonstration of conformity is described in point 6.2.2.8.1.

4.2.6.1.2.2. Materials

All permanent materials used on the unit shall have limited ignitability and flame spread properties, unless

- the material is separated from all potential fire risks on the unit by a fire barrier and the safe application is supported by a risk assessment or
- the component has a mass <400g, and is located within a horizontal distance of ≥ 40 mm and a vertical distance of ≥ 400 mm to other non-tested components.

The demonstration of conformity is described in point 6.2.2.8.2.

4.2.6.1.2.3. Cables

The selection and installation of electrical cables shall take into account their fire behaviour properties.

The demonstration of conformity is described in point 6.2.2.8.3.

4.2.6.1.2.4. Flammable liquids

The unit shall be provided with measures preventing a fire from occurring and spreading due to leakage of flammable liquids or gases.

The demonstration of conformity is described in point 6.2.2.8.4.

4.2.6.2. Protection against electrical hazards

4.2.6.2.1. Protective measures against indirect contact (protective bonding)

The impedance between vehicle body and the running rail shall be low enough to prevent hazardous voltages between them.

Units shall be bonded in accordance with the provisions as described in clause 6.4 of EN 50153:2002.

4.2.6.2.2. Protective measures against direct contact

The electrical installations and equipment of a unit shall be designed so as to protect persons from electric shock.

The unit shall be designed so that direct contact is prevented following the provisions set out in clause 5 of EN 50153:2002.

4.2.6.3. Attachment devices for rear-end signal

On all units designed to receive a rear-end signal, two devices at the end of the unit shall provide for the installation of two lamps or two reflective plates as set out in Appendix E on the same height above rail not higher than 2000 mm. The dimensions and clearance of these attachment devices shall be as described in chapter 1 of ERA technical document ERA/TD/2012-04/INT version 1.0 of 04.06.2012 published on the ERA website (<http://www.era.europa.eu>).

4.3. Functional and technical specification of the interfaces

4.3.1. Interface with the subsystem “infrastructure”

Table 5

Interface with infrastructure subsystem

| | |
|------------------------------|--|
| Reference in this TSI | Reference Commission Decision 2011/275/EU |
|------------------------------|--|

| Reference in this TSI | Reference Commission Decision 2011/275/EU |
|---|---|
| 4.2.3.1 Gauging | 4.2.4.1 Minimum structure gauge 4.2.4.2 Distance between track centres 4.2.4.5 Minimum radius of vertical curve |
| 4.2.3.2 Compatibility with load carrying capacity of lines | 4.2.7.1 Track resistance to vertical loads 4.2.7.3 Lateral track resistance 4.2.8.1 Resistance of bridges to traffic loads 4.2.8.2 Equivalent vertical loading for earthworks and earth pressure effects 4.2.8.4 Resistance of existing bridges and earthworks to traffic loads |
| 4.2.3.5.2 Running dynamic behaviour | 4.2.9 Track geometrical quality |
| 4.2.3.6.2 Characteristics of wheelsets 4.2.3.6.3 Characteristics of wheels | 4.2.5.1 Nominal track gauge 4.2.5.6 Rail head profile for plain line 4.2.6.2 In service geometry of switches and crossings |

4.3.2. *Interface with the subsystem “operation and traffic management”*

Table 6

Interface with operation and traffic management subsystem

| Reference in this TSI | Reference Commission Decision 2011/314/EU |
|---|--|
| 4.2.2.2 Strength of unit - Lifting and jacking | 4.2.3.6.3 Contingency arrangements |
| 4.2.3.1 Gauging | 4.2.2.5 Train composition |
| 4.2.3.2 Compatibility with load carrying capacity of lines | 4.2.2.5 Train composition |
| 4.2.4 Brake | 4.2.2.6 Train braking |
| 4.2.6.3 Attachment devices for rear-end signal. Appendix E Rear-end signal | 4.2.2.1.3.2 Rear-end |

4.3.3. Interface with the subsystem “control, command and signalling”

Table 7

Interface with control, command and signalling subsystem

| Reference in this TSI | Reference Commission Decision 2012/88/EU Annex A, table A2, index 77 |
|---|---|
| 4.2.3.3 a) Rolling stock characteristics compatible with train detection system based on track circuits | <ul style="list-style-type: none"> – axle distances (3.1.2.1, 3.1.2.4, 3.1.2.5 and 3.1.2.6), – axle loads (3.1.7.1 and 3.1.7.2) – electrical resistance (3.1.8). |
| 4.2.3.3 b) Rolling stock characteristics compatible with train detection system based on axle counters | <ul style="list-style-type: none"> – axle distances (3.1.2.1, 3.1.2.3, 3.1.2.5 and 3.1.2.6), – wheel geometry (3.1.3.1 - 3.1.3.4), – metal / inductive components-free space between wheels (3.1.3.5) – wheel material (3.1.3.6). |
| 4.2.3.3 c) Rolling stock characteristics compatible with train detection system based on loop equipment | <ul style="list-style-type: none"> – vehicle metal mass (3.1.7.2). |

4.4. Operating rules

Operating rules are developed within the procedures described in the railway undertaking safety management system. These rules take into account the documentation related to operation which forms a part of the technical file as required in Article 18(3) of and as set out in Annex VI to Directive 2008/57/EC.

The documentation related to operation describes the characteristics of the unit in relation to the design operating state to be considered in order to define the operating rules in normal and in various reasonably foreseeable degraded modes.

The documentation related to operation is composed of:

- a description of operation in normal mode, including the operational characteristics and limitations of the unit (e.g. vehicle gauge, maximum design speed, axle loads, brake performance, compatibility with train detection systems).

- a description of operation in degraded mode (when equipment or functions described in this TSI suffer safety failures) as far as can reasonably be predicted, together with the related acceptable limits and operating conditions of the unit that could be experienced.

The applicant shall provide the initial version of the documentation related to operating rules. This documentation might be modified later in accordance with the corresponding Union legislation, taking into account the existing operating and maintenance conditions of the unit. The Notified Body shall verify only that the documentation on operation is provided.

4.5. Maintenance rules

Maintenance is a set of activities intended to keep a functional unit in, or to restore it to a state in which it can perform its required function.

The following documents being part of the technical file as required in Article 18(3) of and as set out in Annex VI to Directive 2008/57/EC are necessary to undertake maintenance activities on the units:

- General documentation (point 4.5.1)
- The maintenance design justification file (point 4.5.2) and
- The maintenance description file (point 4.5.3).

The applicant shall provide the three documents described in 4.5.1, 4.5.2. and 4.5.3. This documentation might be modified later in accordance with the corresponding EU legislation, taking into account the existing operating and maintenance conditions of the unit. The Notified Body shall verify only that the documentation on maintenance is provided.

4.5.1. General documentation

The general documentation comprises of:

- Drawings and description of the unit and its components.
- Any legal requirement concerning the maintenance of the unit.
- Drawing of systems (electrical, pneumatic, hydraulic and control-circuit diagrams).
- Additional on-board systems (description of the systems including description of functionality, specification of interfaces and data processing and protocols).
- Configuration files for each vehicle (parts list and bill of material) to enable (in particular but not only) traceability during maintenance activities.

4.5.2. Maintenance design justification file

The maintenance design justification file explains how maintenance activities are defined and designed in order to ensure that the rolling stock characteristics will be

kept within permissible limits of use during its lifetime. The file shall give input data in order to determine the criteria for inspection and the periodicity of maintenance activities. The maintenance design justification file consists of

- Precedents, principles and methods used to design the maintenance of the unit.
- Limits of the normal use of the unit (e.g. km/month, climatic limits, foreseen types of loads etc.).
- Relevant data used to design the maintenance and origin of these data (return of experience).
- Tests, investigations and calculations carried out to design the maintenance.

4.5.3. *Maintenance description file*

The maintenance description file describes how maintenance activities can be conducted. Maintenance activities include, among others, inspections, monitoring, tests, measurements, replacements, adjustments and repairs.

Maintenance activities are split into

- preventive maintenance(scheduled and controlled) and
- corrective maintenance.

The maintenance description file includes the following:

- Component hierarchy and functional description which sets up the boundaries of the rolling stock by listing all the items belonging to the product structure of that rolling stock and using an appropriate number of discrete levels. The lowest item of the hierarchy shall be a replaceable component.
- Parts list which shall contain the technical and functional descriptions of the spare parts (replaceable units). The list shall include all parts specified for changing based on condition, which may require a replacement following electrical or mechanical malfunction or which will foreseeable require a replacement after an accidental damage. Interoperability constituents shall be indicated and referenced to their corresponding declaration of conformity.
- Limit values for components which are not to be exceeded in service. It is permitted to specify operational restrictions in degraded mode (limit value reached).
- List of reference to the European legal obligations to which components or subsystems are subject.

- Maintenance plan¹⁰ i.e. the structured set of tasks to perform the maintenance including the activities, procedures and means. The description of this set of tasks includes:
 - (a) Disassembly/assembly instructions drawings necessary for correct assembly/disassembly of replaceable parts.
 - (b) Maintenance criteria.
 - (c) Checks and tests in particular of safety relevant parts; these include visual inspection and non-destructive tests (where appropriate e.g. to detect deficiencies that may impair safety).
 - (d) Tools and materials required to undertake the task.
 - (e) Consumables required to undertake the task.
 - (f) Personal protective safety provision and equipment.
- Necessary tests and procedures to be undertaken after each maintenance operation before re-entry into service of rolling stock.

4.6. Professional competencies

The professional competencies of staff required for the operation and maintenance of units are not covered by this TSI.

4.7. Health and safety conditions

The provisions for health and safety of staff required for the operation and maintenance of units are covered by the essential requirements 1.1.5, 1.3.2, 2.5.1, 2.6.1 set out in Annex III to Directive 2008/57/EC.

In particular, the following points of section 4.2 specify provisions for health and safety of staff:

Point 4.2.2.1.1: End coupling

Point 4.2.6.1: Fire safety

Point 4.2.6.2: Protection against electrical hazards. If the unit is fitted with a manual coupling system, a free space for shunters during coupling and uncoupling shall be provided.

All protruding parts deemed a hazard to operational staff shall be clearly indicated and/or fitted with protective devices.

¹⁰ The maintenance plan shall take into accounts the findings of the ERA Task force on Freight Maintenance (see “Final report on the activities of the Task Force Freight Wagon Maintenance” published on the ERA website <http://www.era.europa.eu>).

The unit shall be equipped with footsteps and handrails except in those cases it is not intended to be operated with staff on-board, e.g. for shunting.

4.8. Parameters to be recorded in the technical file

The technical file shall contain at least the following parameters:

- Type, position and resiliency of the end coupling
- Load due to dynamic traction forces and compressive forces
- Gauge reference profiles to which the unit complies
- Conformity, if any, to target gauge reference profile(s) G1, GA, GB and GC
- Compliance, if any, to gauge lower reference profile(s) GIC1 and GIC2
- Mass per axle (tare and fully laden)
- Position of the axles along the unit and number of axles
- Length of the unit
- Maximum design speed Track gauges(s) the unit can be operated on
- Compatibility with train detection systems (track circuits / axle counters / loop equipment)
- Compatibility with hot axle box detection systems
- In-service temperature range of the axle bearings
- Nature of the signal which controls the brake (example: pneumatic main brake pipe, electric brake type XXX, ...)
- Characteristics of the control line and of its coupling with other units (main brake pipe diameter, section of the electric cable ...)
- Individual nominal performance of the brake unit, depending on the brake mode, if any (response time, brake force, level of adhesion required, ...)
- Braking distance or brake weight depending on the brake mode, if any.
- thermal capacity of the brake components in relation to a braking power expressed in terms of speed and brake application time
- Temperature range and severity level of snow/ice/hail conditions
- Brake weight and maximum gradient of the parking brake (if applicable)
- Ability / inability to be hump shunted
- Presence of footsteps and/or handrails

5. INTEROPERABILITY CONSTITUENTS

5.1. General

Interoperability constituents (ICs), as defined in article 2(f) of Directive 2008/57/EC, are listed in section 5.3 together with

- their area of use covering parameters of the subsystem and
- the reference to corresponding requirements defined in section 4.2.

When a requirement is identified in section 5.3 as being assessed at IC level, an assessment for the same requirement at subsystem level is not required.

5.2. Innovative solutions

As stated in section 4.1, innovative solutions may require new specifications and/or new assessment methods. Such specifications and assessment methods shall be developed by the process described in point 6.1.3 whenever an innovative solution is envisaged for an interoperability constituent.

5.3. Interoperability constituent specifications

5.3.1. *Running gear*

The running gear shall be designed for an application range, the area of use, as defined by the following parameters:

- Maximum speed
- Maximum cant deficiency
- Minimum tare of the unit
- Maximum axle load
- Range of distances between bogie pivots or range of wheelbase of “two-axle units”
- Maximum height of centre of gravity of empty unit
- Coefficient of height of centre of gravity of loaded unit minimum torsional stiffness coefficient of car body
- Maximum mass distribution coefficient for empty units with :

$$\frac{1}{2a^*} \cdot \sqrt{\frac{I_{zz}}{m}}$$

| | |
|----------|---|
| I_{zz} | moment of inertia of the car body relative to the vertical axis through the centre of gravity of the car body |
| m | mass of the car body |
| $2a^*$ | wheelbase |

- Minimum nominal wheel diameter
- Rail inclination

The parameters speed and axle load may be considered in combination in order to define the appropriate area of use (e.g. maximum speed and tare weight).

The running gear shall comply with the requirements expressed in points 4.2.3.5.2 and 4.2.3.6.1. These requirements shall be assessed at IC level.

5.3.2. *Wheelset*

The wheelset shall be assessed and designed for the area of use as defined by

- nominal wheel tread diameter and
- maximum vertical static force.

A wheelset shall comply with the requirements on geometrical and mechanical parameters defined in point 4.2.3.6.2. These requirements shall be assessed at IC level.

5.3.3. *Wheel*

A wheel shall be designed and assessed for an area of use defined by

- nominal tread diameter,
- maximum vertical static force,
- maximum speed and service life and
- maximum braking energy.

A wheel shall comply with the requirements on geometrical, mechanical and thermo mechanical parameters defined in point 4.2.3.6.3. These requirements shall be assessed at IC level.

5.3.4. *Axle*

An axle shall be designed and assessed for an area of use defined by

- maximum vertical static force.

An axle shall comply with the requirements on mechanical parameters defined in point 4.2.3.6.4. These requirements shall be assessed at IC level.

5.3.5. *Rear-end signal*

The rear-end signal, as described in Appendix E, is an independent IC. There are no requirements in section 4.2 dealing with the rear-end signal. Its assessment by the notified body is not part of the EC verification of the subsystem.

6. CONFORMITY ASSESSMENT AND EC VERIFICATION

6.1. Interoperability constituent

6.1.1. Modules

The conformity assessment of an interoperability constituent shall be performed in accordance with the module(s) described in table 8.

Table 8

Modules for conformity assessment of interoperability constituents

| | |
|------------|---|
| Module CA1 | Internal production control plus product verification by individual examination |
| Module CA2 | Internal production control plus product verification at random intervals |
| Module CB | EC-Type examination |
| Module CD | Conformity to type based on quality management system of the production process |
| Module CF | Conformity to type based on product verification |
| Module CH | Conformity based on full quality management system |
| Module CH1 | Conformity based on full quality management system plus design examination |

These modules are specified in detail in the Commission Decision 2010/713/EU.

6.1.2. Conformity Assessment procedures

The manufacturer or his authorised representative established within the Union shall choose one of the modules or module combinations indicated in table 9 in accordance with the required constituent.

Table 9

Modules to be applied for interoperability constituents

| Point | Constituent | Modules | | | | |
|-----------|----------------------------|------------------|-----------|-----------|------------------|-----|
| | | CA1 or CA2 | CB+ CD | CB+ CF | CH | CH1 |
| 4.2.3.6.1 | Running gear | | X | X | | X |
| | Running gear - established | X | | | X | |
| 4.2.3.6.2 | Wheelset | X ^(*) | X | X | X ^(*) | X |

| | | | | | | |
|-----------|-----------------|------------------|---|---|------------------|---|
| 4.2.3.6.3 | Wheel | X ^(*) | X | X | X ^(*) | X |
| 4.2.3.6.4 | Axle | X ^(*) | X | X | X ^(*) | X |
| 5.3.5 | Rear-end signal | X | | | X | |

(*) Modules CA1, CA2 or CH may be used only in the case of products placed on the market, and therefore developed, before the entry into force of this TSI, provided that the manufacturer demonstrates to the NoBo that design review and type examination were performed for previous applications under comparable conditions, and are in conformity with the requirements of this TSI; this demonstration shall be documented, and is considered as providing the same level of proof as module CB or design examination according to module CH1.

Within the application of the chosen module or module combination the interoperability constituent shall be assessed against the requirements mentioned in section 4.2. If necessary, additional requirements concerning the assessment of particular interoperability constituents are given in the following clauses.

6.1.2.1. Running gear

The demonstration of conformity for the running gear is set out in Appendix B section 2.

Units equipped with an established running gear as listed below are presumed to be in conformity with the relevant requirement provided that the running gears are operated within their established area of use:

- (a) Single axle running gear:
 - Double link suspension.
 - Niesky 2.
 - Suspension S 2000.
- (b) Two-axle bogie running gear:
 - Y25 family.
 - Two-axle steering axle bogie.
- (c) Three-axle bogies:
 - Three-axle bogie family with link suspension.

The assessment of the bogie frame strength shall be based on clause 6.2 of EN 13749:2011.

6.1.2.2. Wheelset

The demonstration of conformity for the mechanical behaviour of the wheelset assembly shall be carried out according to clause 3.2.1 of EN13260:2009+A1:2010,

which defines limit values for the axial assembly force and the associated verification test.

A verification procedure shall exist to ensure at the assembly phase that no defects may detrimentally affect safety due to any change in the mechanical characteristics of the fitted parts of the axle.

6.1.2.3. Wheel

- (a) Forged and rolled wheels: The mechanical characteristics shall be proven following the procedure as specified in clause 7 of EN 13979-1:2003+A1:2009+A2:2011.

If the wheel is intended to be used with brake blocks acting on the wheel running surface, the wheel shall be thermo mechanically proven by taking into account the maximum braking energy foreseen. A type test, as described in clause 6.2 of EN 13979-1:2003+A1:2009+A2:2011 shall be performed in order to check that the lateral displacement of the rim during braking and the residual stress are within the specified tolerance limits.

The decision criteria of residual stresses for forged and rolled wheels are set out in EN 13979-1:2003+A1:2009+A2:2011.

- (b) Other types of wheels: Other types of wheels are permitted for units in national use. In that case the decision criteria and the fatigue stress criteria shall be specified in national rules. Those national rules shall be notified by Member States in accordance with Article 17(3) of Directive 2008/57/EC.

A verification procedure shall exist to ensure at the production phase that no defects may detrimentally affect safety due to any change in the mechanical characteristics of the wheels. The tensile strength of the material in the wheel, the hardness of the running surface, the fracture toughness (only for tread-braked wheels), resistance to impact, the material characteristics and the material cleanliness shall be verified. The verification procedure shall specify the batch sampling used for each characteristic to be verified.

6.1.2.4. Axle

In addition to the requirement on the assembly above, the demonstration of conformity of mechanical resistance and fatigue characteristics of the axle shall be based on clauses 4, 5 and 6 of EN13103:2009+A1:2010.

The decision criteria for the permissible stress are specified in clause 7 of EN 13103:2009+A1:2010. A verification procedure shall exist to ensure at the production phase that no defects may detrimentally affect safety due to any change in the mechanical characteristics of the axles. The tensile strength of the material in the axle, the resistance to impact, the surface integrity, the material characteristics and the material cleanliness shall be verified. The verification procedure shall specify the batch sampling used for each characteristic to be verified.

6.1.3. Innovative solutions for Interoperability Constituents

If an innovative solution (as defined in point 4.2.1) is proposed for an interoperability constituent as defined in section 5.2, the manufacturer or his authorised representative established within the Union shall state the deviations from the relevant point of this TSI and submit them to the European Commission for analysis. In case the analysis results in a favourable opinion, the appropriate functional and interface specifications as well as the assessment method which are necessary to be included in the TSI in order to allow the use of this constituent will be developed.

The appropriate functional and interface specifications and the assessment methods so produced shall be incorporated in the TSI by the revision process.

By the notification of a decision of the Commission, taken in accordance with Article 29 of Directive 2008/57/EC, the innovative solution may be permitted to be used.

6.2. Subsystem

6.2.1. Modules

The EC verification of the subsystem “Rolling stock – freight wagons” shall be performed in accordance with the module(s) described in table 10.

Table 10

Modules for EC verification of subsystems

| | |
|-----|---|
| SB | EC-Type Examination |
| SD | EC verification based on quality management system of the production process |
| SF | EC verification based on product verification |
| SH1 | EC verification based on full quality management system plus design examination |

These modules are specified in detail in the Decision 2010/713/EU.

6.2.2. EC verification procedures

The applicant shall choose one of the following combinations of modules or module for the EC verification of the subsystem.

- (SB+SD) or
- (SB+SF) or
- (SH1).

Within the application of the chosen module or module combination the subsystem shall be assessed against the requirements mentioned in section 4.2. If necessary,

additional requirements concerning the assessment of particular constituents are given in the following clauses.

6.2.2.1. Strength of unit

The demonstration of conformity shall be in accordance with chapters 6 and 7 of EN 12663-2:2010.

Regarding joints, a recognised verification procedure shall exist to ensure at the production phase that no defect may decrease the intended mechanical characteristics of the structure.

6.2.2.2. Safety against derailment running on twisted track

The demonstration of conformity shall be carried out either in accordance with

- the procedure defined in section 4.1 of EN 14363:2005 or
- the method given in section 4.2 of EN15839:2012 by using the pre-calculation for standardised solutions.

6.2.2.3. Running dynamic behaviour

On-track tests

The demonstration of conformity shall be carried out in accordance with Chapter 5 of EN 14363:2005.

As an alternative to perform on-track tests on two different rail inclinations, as set out in clause 5.4.4.4 in EN 14363:2005, it is permitted to perform tests on only one rail inclination if it is demonstrated that the tests cover the range of contact conditions as defined in Appendix B, section 1.1.

When an on-track test with normal measuring method is required the unit shall be assessed against the limit values set out in Appendix B.1.2 and B.1.3.

The combination of the highest equivalent conicity and speed for which the unit meets the stability criterion in clause 5 of EN 14363:2005 shall be recorded in the report.

The required test conditions for on-track tests, as set out in EN 14363:2005, are not always fully achievable concerning

- track geometric quality and
- combinations of speed, curvature, cant deficiency.

In cases this is not fully achievable the demonstration of conformity is an open point.

Simulations

Alternatively, under the conditions stated in section 9.3 of EN 15827:2011, a simulation may replace the above mentioned on-track tests.

6.2.2.4. Axle box / bearings

The demonstration of conformity for mechanical resistance and fatigue characteristics of the rolling bearing shall be in accordance with clause 6 of EN12082:2007+A1:2010.

6.2.2.5. Running gear for manual change of wheelsets

Changeover between 1435 mm and 1668 mm track gauges

The technical solutions described in the following figures of the UIC leaflet 430-1:2006 are deemed to be compliant with the requirements in point 4.2.3.6.7 :

- for axle units: figures 9 and 10 of Annex B.4, and figure 18 of Annex H of UIC leaflet 430-1:2006,
- for bogie units: figure 18 of Annex H of UIC leaflet 430-1:2006.

Changeover between 1435 mm and 1524 mm track gauges

The technical solution described in Appendix 7 of UIC leaflet 430-3:1995 is deemed to be compliant with the requirements in point 4.2.3.6.7.

6.2.2.6. Thermal capacity

Calculations, simulations or tests shall demonstrate that the temperature of the brake block, brake pad or brake disc does not exceed their thermal capacity. The following shall be taken into account:

- (a) Concerning the emergency brake application: the critical combination of speed and payload considering straight and level track, minimum wind and dry rails
- (b) Concerning the continuous brake application:
 - the range up to the maximum braking power,
 - the range up to the maximum speed and
 - the corresponding brake application time.

6.2.2.7. Environmental conditions

Steel materials are deemed to comply with all the ranges indicated in point 4.2.5 if the material properties are determined down to -20°C.

6.2.2.8. Fire safety

6.2.2.8.1. Barriers

Barriers shall be tested in accordance with EN1363-1:1999. Steel sheets of at least 2 mm thickness and aluminium sheets of at least 5 mm thickness are deemed to comply with the integrity requirements without testing.

6.2.2.8.2. Materials

Testing of the materials ignitability and flame spread properties shall be performed in accordance with ISO 5658-2:2006/Am1:2011 for which the limit value shall be $CFE \geq 18 \text{ kW/m}^2$.

For the following materials and components the fire safety requirements are deemed to comply with the required ignitability and flame spread properties:

- Metals and alloys with inorganic coatings (such as, but not limited to: galvanized coating, anodic coating, chromate film, phosphate conversion coating).
- Metals and alloys with an organic coating with a nominal thickness less than 0.3 mm (such as, but not limited to paints, plastic coating, asphaltic coating).
- Metals and alloys with a combined inorganic and organic coating of which the nominal thickness of the organic layer is less than 0.3 mm.
- Glass, stoneware, ceramic and natural stone products.
- Materials that meet the requirements of category C-s3, d2 or higher in accordance with EN 13501-1:2007+A1:2009.

6.2.2.8.3 Cables

The electrical cables shall be selected and installed in accordance with EN 50355:2003 and EN 50343:2003.

6.2.2.8.4 Flammable liquids

The measures taken shall be in accordance with TS 45545-7:2009.

6.2.3. *Innovative solutions*

If the subsystem “Rolling stock – freight wagons” includes an innovative solution (as defined in section 4.1), the applicant shall state the deviations from the relevant clauses of the TSI, and submit them to the Commission for analysis. In case the analysis results in a favourable opinion, the appropriate functional and interface specifications as well as the assessment methods which are necessary to be included in the TSI in order to allow this solution will be developed.

The appropriate functional and interface specifications and the assessment methods so produced shall then be incorporated in the TSI by the revision process.

By the notification of a decision of the Commission, taken in accordance with Article 29 of Directive 2008/57/EC, the innovative solution may be permitted to be used.

6.3. Subsystem containing components corresponding to an interoperability constituents not holding an EC declaration

A Notified Body is permitted to issue an EC certificate of verification of a subsystem, even if one or more of the components corresponding to interoperability

constituents incorporated within the subsystem are not covered by a relevant EC declaration of conformity in accordance with this TSI (non-certified ICs), in any of the following cases:

- (a) The constituent falls under the transition period as set out in Article 8;
- (b) The constituent was manufactured before the entry into force of this TSI and the type of constituent has been
 - used in a subsystem already approved, and
 - put in service in at least one Member State before the entry in force of this TSI.

The EC verification of the subsystem shall be carried out by the Notified Body against the requirements of Chapter 4 by using the corresponding requirements concerning assessment in Chapter 6 together with Chapter 7 except for specific cases. For this EC verification the modules of the subsystem, set out in point 6.2.2, apply.

EC declarations of conformity or suitability for use shall not be drawn up for the components assessed in this manner.

6.4. Project phases where assessment is required

The assessment shall cover the following two phases as identified by “X” in the table F.1 of Appendix F in this TSI. In particular, where a type test is identified the conditions and requirements of section 4.2 shall be considered.

- (a) Design and development phase:
 - Design review and/or design examination
 - Type test: test to verify the design, if and as defined in the section 4.2.
- (b) Production phase:
 - Routine test to verify the conformity of production. The entity in charge of the assessment of the routine tests is determined according to the assessment module chosen.

Appendix F is structured according to section 4.2. Where relevant, a reference to the points of sections 6.1 and 6.2 is given.

6.5. Constituents holding an EC declaration of conformity

Where a constituent has been identified as an IC and held an EC declaration of conformity before the entry into force of this TSI, its treatment under this TSI is set out as follows:

- (a) In the case this constituent is not recognised as an IC in this TSI, neither the certificate nor the declaration are valid for the EC verification procedure related to this TSI.

- (b) The following ICs shall not require a new conformity assessment under this TSI until the expiry of the corresponding certificate or declaration:
- Wheelset.
 - Wheel.
 - Axle.

7. IMPLEMENTATION

7.1. Authorisation for placing in service

This TSI is applicable to the subsystem “rolling stock - freight wagons” within the scope set out in its sections 1.1, 1.2 and Chapter 2 which are placed in service after the date of application of this TSI.

7.1.1. *Authorisation for placing in service of a new vehicle in conformity with the previous WAG TSIs*¹¹

See Article 9.

7.1.2. *Mutual recognition of the first authorisation of placing in service*

In accordance with Article 23(1) of Directive 2008/57/EC the following list lays out the conditions under which a unit, once authorised for placing in service in one Member State, shall not be subject to any additional authorisation for placing in service. These conditions shall be seen as complementary to the requirements in section 4.2. These following conditions must be fulfilled in their entirety:

- (a) The running dynamic behaviour of the unit must have been assessed to the full range of track geometric qualities and all combinations of speed, curvature, cant deficiency set out in EN 14363:2005 (point 4.2.3.5.2). Alternatively the unit must be equipped with running gear, either certified or established, in accordance with point 6.1.2.1.
- (b) The axle bearing condition must be possible to be monitored by line side detection equipment of the network the unit is intended to be operated on considering the conditions of clauses 4.2.3.4.
- (c) The unit must not be equipped with variable gauge wheelsets (point 4.2.3.6.6).
- (d) The unit must be equipped with forged and rolled wheels assessed according to point 6.1.2.3 a).
- (e) The compliance/non-compliance with the requirements regarding the axle bearing condition monitoring by line side equipment as set out in point 7.3.2.2. a) must be recorded in the technical file.

¹¹ Commission Decision 2006/861/EC (OJ L 344, 8.12.2006, p.1) and Commission Decision 2006/861/EC amended by Commission Decision 2009/107/EC (OJ L 45, 14.12.2009, p.1)

- (f) Units intended to operate on the 1668 mm track gauge network must comply with the requirements regarding the axle bearing condition monitoring by line side equipment as set out in point 7.3.2.2 b).
- (g) The reference profile established for the unit as per point 4.2.3.1 must be allocated to one of the target reference profile(s) G1, GA, GB and GC including those used for the lower part GIC1 and GIC2.
- (h) The unit must be compatible with the train detection systems based on track circuits, on axle counters and on loop equipment as specified in clauses 4.2.3.3(a), 4.2.3.3(b) and 4.2.3.3(c).
- (i) The unit must be equipped with the manual coupling system in accordance with the prescriptions set out in Appendix C section 1 including the fulfilment of section 8 or with any semi-automatic or automatic standardised coupling system.
- (j) The brake system must be in accordance with the conditions of Appendix C sections 9, 14 and 15 when applying the reference case set out in point 4.2.4.2. If the brake system requires brake blocks acting on the wheel tread, only the brake blocks listed in Appendix G shall be used.
- (k) The unit must be marked with all applicable markings in accordance with EN15877-1:2012, in particular with the marking on:
 - (i) the allocated interoperable gauge,
 - (ii) the vehicle tare weight,
 - (iii) the vehicle load table,
 - (iv) the length over buffers,
 - (v) the maintenance dates,
 - (vi) the lifting and re-railing signs,
 - (vii) the distance between the two end axles of the unit,
 - (viii) the distance between bogie centres,
 - (ix) the brake weight and
 - (x) the track gauge(s) the unit is compatible with and was assessed for.

7.2. Substitution, renewal and upgrading

This section deals with

- substitutions of constituents as referred to in Article 2(p) of Directive 2008/57/EC and

- the renewal or upgrading of freight wagons, including the substitution of elements within a unit, in accordance with the conditions laid down in Article 20 of Directive 2008/57/EC.

Concerning the substitution of constituents the following categories have to be considered.

- Certified ICs: Components which correspond to an IC in Chapter 5 and which are holding a certificate of conformity.
- Other components: Any component, which is not corresponding to an IC in Chapter 5.
- Non-certified ICs: Components which correspond to an IC in Chapter 5 but are not holding a certificate of conformity and which are produced before the expiry of the transitional period referred to in section 6.3.

Table 11 shows the possible permutations.

Table 11

Substitution permutation table

| | ...substituted by... | | |
|-----------------------------|----------------------|---------------------|----------------------|
| | ...certified ICs | ...other components | ...non-certified ICs |
| Certified ICs... | check | not possible | check |
| Other components... | not possible | check | not possible |
| Non-certified ICs... | check | not possible | check |

The entity in charge of maintenance (ECM) may under its responsibility substitute a component by another one utilising the same function and performance in accordance with the relevant TSI requirements considering these components are

- suitable, i.e. conform to the relevant TSI(s),
- used within its area of use,
- enabling interoperability,
- meeting the essential requirements and
- in line with restrictions eventually stated in the technical file.

When the extent of the work leads to a different function or performance or in case of a substitution of an element within the unit, the contracting entity or the manufacturer is required to send the Member State concerned a file describing the

project as set out in Article 20 of Directive 2008/57/EC. The Member State decides whether a new authorisation for placing in service is needed.

7.3. Specific cases

7.3.1. Introduction

The specific cases, as listed in point 7.3.2, are classified as:

- “P” cases: “permanent” cases.
- “T” cases: “temporary” cases, where it is recommended that the target system is reached by 2020 (an objective set in Decision 2010/661/EU of the European Parliament and of the Council of 7 July 2010 on Union guidelines for the development of the trans-European transport network¹²).

7.3.2. List of specific cases

7.3.2.1. General specific cases

Units running between a Member State and a third country with a network with 1520 mm track gauge: Specific case Finland, Poland and Sweden.

(“P”) The application of national technical rules instead of the requirements in this TSI is allowed for third countries rolling stock.

7.3.2.2. Axle bearing condition monitoring (point 4.2.3.4)

a) Specific case Sweden

(“T”) Units intended to operate on the Swedish railway network shall be compliant with the target and prohibitive zones as set out in table 12.

The two zones underneath the axle box/journal set out in table 12 referring to the parameters of the standard EN 15437-1:2009 shall be free to facilitate vertical monitoring by trackside axle box detection system:

Table 12

Target and prohibitive zone for units intended to be operated in Sweden

| | Y_{TA} [mm] | W_{TA} [mm] | L_{TA} [mm] | Y_{PZ} [mm] | W_{PZ} [mm] | L_{PZ} [mm] |
|----------|--------------------------------------|--------------------------------------|--------------------------------------|--------------------------------------|--------------------------------------|--------------------------------------|
| System 1 | 862 | ≥40 | whole | 862 | ≥60 | ≥500 |
| System 2 | 905±20 | ≥40 | whole | 905 | ≥100 | ≥500 |

¹² OJ L 204, 5.8.2010, p. 1.

Units mutually recognised in accordance with point 7.1.2 and units equipped with on-board axle bearing condition monitoring equipment are exempted from this specific case.

b) Specific case Portugal

(“P”) Units intended to operate on the Portuguese railway network shall be compliant with the target and prohibitive zones as set out in table 13.

Table 13

Target and prohibitive zone for units intended to be operated in Portugal

| | Y_{TA} [mm] | W_{TA} [mm] | L_{TA} [mm] | Y_{PZ} [mm] | W_{PZ} [mm] | L_{PZ} [mm] |
|----------|--------------------------------------|--------------------------------------|--------------------------------------|--------------------------------------|--------------------------------------|--------------------------------------|
| Portugal | 1000 | ≥65 | ≥100 | 1000 | ≥115 | ≥500 |

7.3.2.3. Safety against derailment running on twisted track (point 4.2.3.5.1)

Specific case UK for Great Britain

(“P”) The limitations to the use of Method 3 set out in EN14363:2005 point 4.1.3.4.1 are not applicable for units that are intended for national use on the UK mainline network only.

7.3.2.4. Running dynamic behaviour (point 4.2.3.5.2)

Specific case UK for Great Britain

(“P”) The limitations to the use of Method 3 set out in EN14363:2005 clause 4.1.3.4.1 are not applicable for units that are intended for national use on the UK mainline network only.

7.3.2.5. Characteristics of wheelsets (point 4.2.3.6.2)

Specific case UK for Great Britain

(“P”) For units intended to operate solely on the railway network of Great Britain the characteristics of the wheelsets may be in accordance with the national technical rules notified for this purpose.

7.3.2.6. Characteristics of wheels (point 4.2.3.6.3)

Specific case UK for Great Britain

(“P”) For units intended to operate solely on the railway network of Great Britain the characteristics of the wheels may be in accordance with the national technical rules notified for this purpose.

7.3.2.7. Attachments devices for rear end signals (point 4.2.6.3)

Specific case Ireland and UK for Northern Ireland

(“P”) The attachment devices for rear-end signals are not mandatory for units intended to be operated only in traffic not crossing a border between EU Member States on networks with 1600mm track gauge.

7.4. **Specific environmental conditions**

Specific conditions Finland and Sweden

For unrestricted access of rolling stock to the Finnish and Swedish network under winter conditions, it shall be demonstrated that the rolling stock meets the following requirements:

- Temperature zone T2 as specified in point 4.2.5 shall be selected.
- Snow, ice and hail severe conditions as specified in point 4.2.5 shall be selected.

Specific conditions Portugal and Spain

For unrestricted access of rolling stock to the Portuguese and Spanish network under summer conditions, temperature zone T3 as specified in point 4.2.5 shall be selected.

7.5. **Freight wagons operating under national, bilateral, multilateral or international agreements**

See Article 6.

Appendix A: Open Points

Certain technical aspects, corresponding to the essential requirements, which are not explicitly covered by the specifications, are open points. These are stipulated in sections 4.2 and 6.2 and listed in table A.1.

Table A.1

List of open points

| Element of the Rolling Stock sub-system | Point | Technical aspect not covered by this TSI | Link to other subsystems to cover the open point |
|---|---------------------|---|---|
| Axle bearing condition monitoring | 4.2.3.4 | Option on board equipment | Equipment not mandatory. |
| Test conditions for on-track tests as set out in the EN 14363 are not always fully achievable | 6.2.2.3 (4.2.3.5.2) | track geometric quality and combinations of speed, curvature, cant deficiency (point 5.4.2 of EN 14363). | |
| Variable gauge wheelsets | 4.2.3.6.6 | Assessment concerning the following requirement: The changeover mechanism of the variable gauge wheelset shall ensure the safe locking in the correct intended axial position of the wheel and any brake equipment attached. | |
| Composite brake blocks in Appendix G | 7.1.2 C.14 | Assessment by a notified body | |

Appendix B: Specific procedures for running dynamics

1. Specific assessment concerning running dynamic testing following EN 14363

1.1. Conditions for testing on one rail inclination

- The parameter equivalent conicity $\tan \gamma_e$ for tangent track and large radius curves shall be distributed so that $\tan \gamma_e = 0,2 \pm 0,05$ occurs in a range of the amplitude (y) of the wheelsets lateral displacement between ± 2 and ± 4 mm for a minimum of 50% of track sections.
- The instability criterion in EN14363:2005 shall be assessed for low-frequency body motions on at least two track sections with equivalent conicities less than 0.05 (mean value over the track sections).
- The instability criterion in EN14363:2005 shall be assessed on at least two track sections with equivalent conicities in accordance with table B.1.

Table B.1

Conditions for contact conditions in relation to on-track testing

| Maximum vehicle speed | Equivalent conicity |
|--|----------------------------|
| $60 \text{ km/h} < V < 140 \text{ km/h}$ | $>0,50$ |
| $140 \text{ km/h} < V < 200 \text{ km/h}$ | $>0,40$ |
| $200 \text{ km/h} < V \leq 230 \text{ km/h}$ | $\geq 0,35$ |
| $230 \text{ km/h} < V \leq 250 \text{ km/h}$ | $\geq 0,30$ |

1.2. Limit values for running safety

The limit values for running safety specified in clause 5.3.2.2 of EN 14363:2005 and for axle loads above 22.5 t in clause 5.3.2.2 of EN 15687:2010 shall be met and verified.

When the quotient of guiding force and wheel force (Y/Q) limit is exceeded, it is allowed to recalculate the Y/Q estimated maximum value in accordance with the following process:

- create an alternative test zone made up of all track sections with $300 \text{ m} \leq R \leq 500 \text{ m}$,
- for the statistical processing per section, use ξ_i (97,5%) instead of ξ_i (99,85%),
- for statistical processing per zone, replace $k = 3$ (when using one-dimensional method) or Student coefficient t ($N - 2$; 99%) (when using two-dimensional method) by Student coefficient t ($N-2$; 95%).

Both results (before and after recalculation) shall be reported.

1.3. Track loading limit values

The limit values for track loading specified in EN 14363:2005 clause 5.3.2.3 and for loads above 22.5 t in EN 15687:2010 clause 5.3.2.2 shall be met and verified when so required by the methodology of EN 14363:2005.

The quasi-static guiding force Y_{qst} limit value shall be evaluated for curve radii $250 \leq R < 400$ m.

The limit value shall be:

- $(Y_{qst})_{lim} = (30 + 10500/R_m)$ kN
- $(Y_{qst})_{lim} = (33 + 11550/R_m)$ kN for the 1668 mm track gauge network,

where R_m = mean radius of the track sections retained for the evaluation.

When this limit value is exceeded due to high friction conditions, it is permitted to recalculate the estimated value of Y_{qst} on the zone after replacing the individual $(Y_{qst})_i$ values on the track sections "i" where $(Y/Q)_{ir}$ (mean value of Y/Q ratio on the inner rail over the section) exceeds 0,40 by: $(Y_{qst})_i - 50[(Y/Q)_{ir} - 0,4]$. Both results (before and after recalculation) shall be reported.

The values of the Y_{qst} , Q_{qst} and mean curve radius (before and after recalculation) shall be recorded in the test report.

In case the Y_{qst} value exceeds the limit value expressed above, the operational performance of the unit (e.g. maximum speed) may be limited by the network, considering track characteristics (e.g. curve radius, cant, rail height).

2. Qualification of running gear

Following successful testing the acceptable parameter variation range is given by the range between the nominal tested parameters extended as illustrated in figure B.2.

It is permitted to perform only one test and by doing so only validating the running gear for a limited range.

Fig. B.2

Parameter variation ranges for the acceptance after successful testing compared to the process in EN 14363:2005

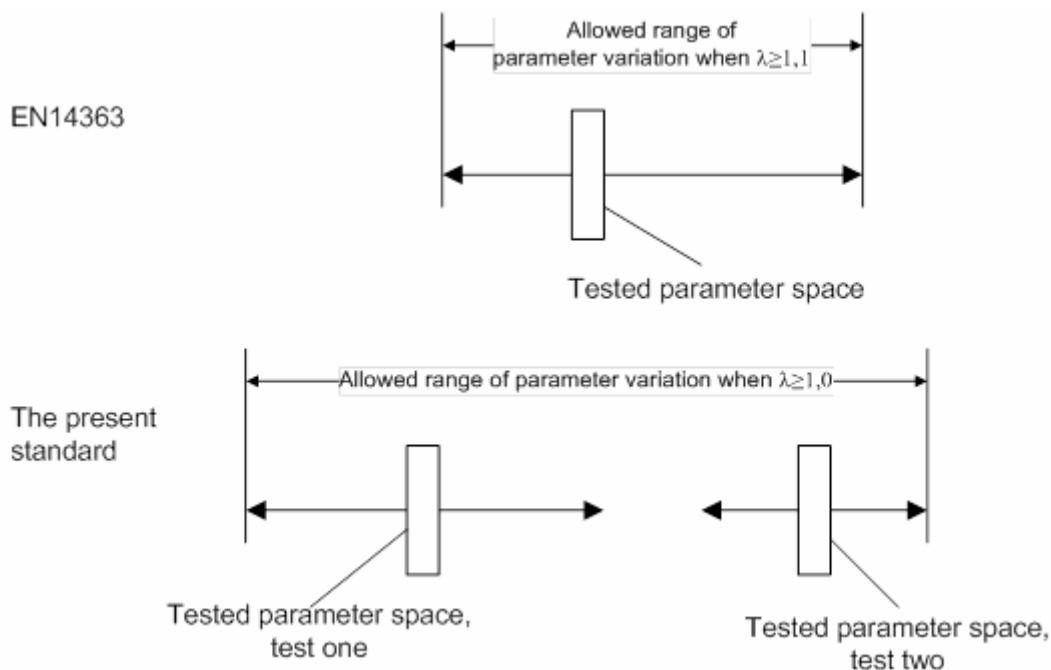

2.1. Test extent

The tests shall be carried out in accordance with the complete procedure in chapter 5 of EN14363:2005, considering the specific procedures as set out in Appendix B.1.

Units with an axle load higher than 22,5 t up to 25t shall be tested in accordance with EN 15687:2010.

The tests shall be performed for the same intended operating conditions (v_{adm} and I_{adm}):

- One test with a wagon of short running gear distance.
- One test with a wagon of long running gear distance

Other values of body parameters shall be within the ranges defined in table B.3.

Table B.3

Body parameters

| | | 2-axle wagons | | Bogie wagons | |
|--|----------------------------------|---|-----------------|------------------|-----------------|
| | | Short test wagon | Long test wagon | Short test wagon | Long test wagon |
| Distance between running gear | $2a^*$ [m] ^{a)} | ≤ 7 | ≥ 9 | ≤ 7 | ≥ 13 |
| Acceptable range of torsional coefficient of vehicle body | c_t^* [kNmm ² /rad] | 0,5 x10 ¹⁰ ... 8 x10 ¹⁰ | | | |
| a) $2a^*$ is the distance between wheelsets for 2-axle wagons or the distance between bogies for bogie wagons and c_t^* is the vehicle body torsional stiffness coefficient. | | | | | |

Note 1: For the purposes of assessment of running behaviour a typical loading condition must be tested. It is not necessary to test the worst position of the centre of gravity.

In addition, two axle wagons for speeds ≥100 km/h shall be tested in loaded condition also in sections of test zone 2 with clearances given by a gauge of ≥1450 mm in combination with wheelsets having distances between active faces at the minimum operation limit.

If the design parameters and the operation parameters require the application of the normal measuring method, it is nevertheless acceptable to perform such tests with one of the vehicles based on measurements of lateral acceleration. In that case, it shall be demonstrated that a relationship exists between accelerations and the sum of the guiding forces on the vehicle tested according to the normal measuring method and a related limit value shall be established.

Note 2: This requirement is an extension of the application of the simplified measuring method, using information gathered with vehicle tested according to the normal measuring method.

Note 3: This requirement is intended to be transferred to the test conditions in EN 14363:2005.

2.2. Range of running gear parameters for dispensation from on-track tests

Following successful testing in accordance with Appendix B section 2.1 the acceptable parameter variation range for dispensation from on-track tests is given by the range between the nominal tested parameters of the running gear and the extended range as illustrated in figure B.2 and specified in tables B.4 and B.5.

All parameters given in these tables are nominal values. The upper limit of the acceptable range depends on the maximum tested value of the respective parameter, the lower limit on the minimum tested value.

In case of extension of the already applicable parameter range of a running gear, new tests shall be performed with parameters outside the previously tested range.

Table B.4

Accepted parameter ranges for a single axle running gear which was tested successfully in accordance with Appendix B section 2.1

| Nominal parameter | | Minimum | Maximum |
|---|--------|---|---|
| Maximum axle load | P | - | P_{tested} |
| Vertical eigenfrequency | v_z | $0.9 v_z$ in load range | $1.12 v_z$ in load range |
| Vertical damping | | Nominal characteristics of tested running gear | |
| Lateral and longitudinal suspension characteristics | | Nominal characteristics of tested running gear | |
| Distance between centres of axle bearings (suspension base) | $2b_z$ | $2b_{z, \text{tested}} - 100 \text{ mm}$ | $2b_{z, \text{tested}} + 170 \text{ mm}$ |
| Wheel diameter | D | Diameter of tested application $D_{\text{tested}} - 90 \text{ mm}$ | Diameter of tested application $D_{\text{tested}} + 90 \text{ mm}$ |

Table B.5

Accepted parameter ranges for a bogie which was tested successfully in accordance with Appendix B section 2.1

| Nominal parameter | | Minimum | Maximum |
|---|------------------|---|---|
| Maximum axle load | P_{max} | - | $1,05 \cdot P_{\text{max, tested}}$ |
| Bogie axle distance (between outer axles of the bogie) | $2a^+$ | $2a^+_{\text{tested}}$ | $2a^+_{\text{tested}} + 0,2 \text{ m}$ |
| Vertical eigenfrequency (see Appendix C) | v_z | $0,90 \cdot v_{z, \text{tested}}$ in full range between empty and loaded conditions | $1,12 v_{z, \text{tested}}$ in full range between empty and loaded conditions |
| Vertical Damping | | Nominal characteristics of tested running gear | |
| Axle guiding longitudinal | | Nominal characteristics of tested running gear | |
| Axle guiding lateral | | Nominal characteristics of tested running gear | |
| Lateral secondary | | Nominal characteristics of tested running gear | |

| | | | |
|---|------------|------------------------------------|-------------------------------------|
| susp.-characteristics | | | |
| Distance between centres of axle bearings (suspension base) | $2bz$ | $2bz$, tested -100 mm | $2bz$, tested +170 mm |
| Yaw resistance of bogie ^{a)} | M_z^* | $0,80 \cdot M_{z,\text{tested}}^*$ | $1,20 \cdot M_{z,\text{tested}}^*$ |
| Moment of inertia of whole bogie (around z-axis) | I_{zz}^* | - | $1,10 \cdot I_{zz,\text{tested}}^*$ |
| Wheel diameter | D | $D_{\text{tested}} - 90$ mm | $D_{\text{tested}} + 90$ mm |
| Nominal height of centre pivot | h_{cp} | $h_{cp,\text{tested}} - 150$ mm | $h_{cp,\text{tested}} + 50$ mm |
| ^{a)} for a friction based yaw resistance torque measured at two specified loads typical for empty and loaded condition. For other systems, appropriate parameters must be used to control stability and safety against derailment in empty condition and maximum guiding force in loaded conditions. | | | |

2.3 Range of vehicle body parameters for dispensation from on-track tests

Following successful testing according to Appendix B section 2.1 the acceptable parameter variation range for a dispensation from on-track tests is given by the range between the nominal tested parameters of the vehicle body and the extended range where applicable as specified in table B.5. All parameters given in this table are nominal values. The upper limit of the acceptable range depends on the maximum tested value of the respective parameter, the lower limit on the minimum tested value.

To extend the applicable vehicle parameter range of a standardised running gear, test results of a third tested vehicle outside the previously tested range shall be used.

Table B.6

Accepted parameter range for vehicles (including articulated wagons and permanently coupled units) equipped with a running gear which was tested successfully according to Appendix B section 2.1

| Nominal parameter | | Minimum | Maximum |
|--|----------|---|---|
| Distance between wheelsets (non bogie vehicles) | $2a^*$ | Lowest value of either 6 m or $2a^*$ tested | Highest value of either 10 m or $2a^*$ tested |
| Distance between centres bogies (bogie vehicles) | $2a^*$ | Lowest value of either 6,5 m or $2a^*$ tested | $2a^*$ tested + 3m |
| Centre of gravity height of empty wagon | h_{cg} | - | $1,2 \cdot h_{cg,\text{empty,tested, max}}$ |

| | | | |
|---|-------------------------|--|--|
| Coefficient of height of centre of gravity - loaded vehicle ^{a)} | χ | - | $\chi_{\text{loaded, tested, max}} \times (1 + 0,8(\lambda' - 1))$ with $\lambda\lambda$ – factor for track loading parameters. |
| Torsional coefficient per vehicle body | c_t^* | $> 0,5 \cdot 10^{10} \text{ kNmm}^2/\text{rad}$ | '- |
| Mean axle load of the tare unit (non-bogie wagon) | $P_{\text{mean, tare}}$ | Smallest value of either 5,75 t or $P_{\text{mean, tare, tested}}$ | - |
| Mean axle load of the tare unit (bogie wagon) | $P_{\text{mean, tare}}$ | Smallest value of either 4 t or $P_{\text{mean, tare, tested}}$ | - |
| Maximum axle load | P | - | $1,05 \cdot P_{\text{tested}}$ |
| Mass distrib. coefficient (empty and loaded vehicle) | Φ | - | $1,2 \cdot \Phi_{\text{tested}}$ |
| ^{a)} for evaluation of χ use admissible cant deficiency l_{adm} of 130 mm for axle loads $\leq 225 \text{ kN}$ and 100 mm for axle loads $> 225 \text{ kN}$ and up to 250 kN. | | | |

Appendix C: Additional optional conditions

The compliance with the following set of conditions C.1 to C.18 is optional. If the applicant selects this option, a notified body has to assess the compliance within the EC verification procedure.

1. Manual coupling system

The manual coupling system shall comply with the following requirements:

- The screw coupling system excluding the draw hook shall comply with the requirements related to freight wagons of EN15566:2009+A1:2010 except clause 4.4,
- The draw hook shall comply with the requirements related to freight wagons of EN15566:2009+A1:2010 except clause 4.4 and except the dimension “a” in Annex A Figure A.1 which shall be treated as informative.
- The draw hook shall be located at a height between 920 and 1045 mm above rail level in all loading and wear conditions.
- The centreline of the draw hook shall be located within a range of 0 to 20mm below the buffing centre.
- The clearance for the draw hook shall be in accordance with chapter 2 of ERA technical document ERA/TD/2012-04/INT version 1.0 of 04.06.2012 published on the ERA website (<http://www.era.europa.eu>).
- The buffer shall comply with the requirements related to freight wagons of EN15551:2009+A1:2010.
- The buffing centre line shall be located at a height between 940 and 1065 mm above rail level in all loading and wear conditions.
- There shall be no fixed parts within 40 mm of a vertical plane placed at the end of the fully compressed buffers.
- The space for shunting staff operation shall be in accordance with chapter 3 of ERA technical document ERA/TD/2012-04/INT version 1.0 of 04.06.2012 published on the ERA website (<http://www.era.europa.eu>).
- Where a combined automatic and screw coupler is fitted, it is permissible for the auto coupler head to infringe the space specified above for shunting staff on the left hand side when it is stowed and the screw coupler is in use. In this case the marking in figure 75 of EN15877-1:2012 is mandatory.

Interaction of buffers and draw gear

- The characteristics of the buffers and draw gear shall be designed in order to enable the safe transit of curves in the track with a radius of 150 m. Two units with bogies coupled on straight track with touching buffers shall generate

compressive forces not higher than 250 kN on a 150 m radius curve. There is no requirement specified for two axle units.

- The distance between the front edge of a draw-hook opening and the front side of the fully extended buffers shall be 355 mm +45/-20 mm in the new condition as shown in Figure C.1:

Fig. C.1

Configuration of buffers and draw gear

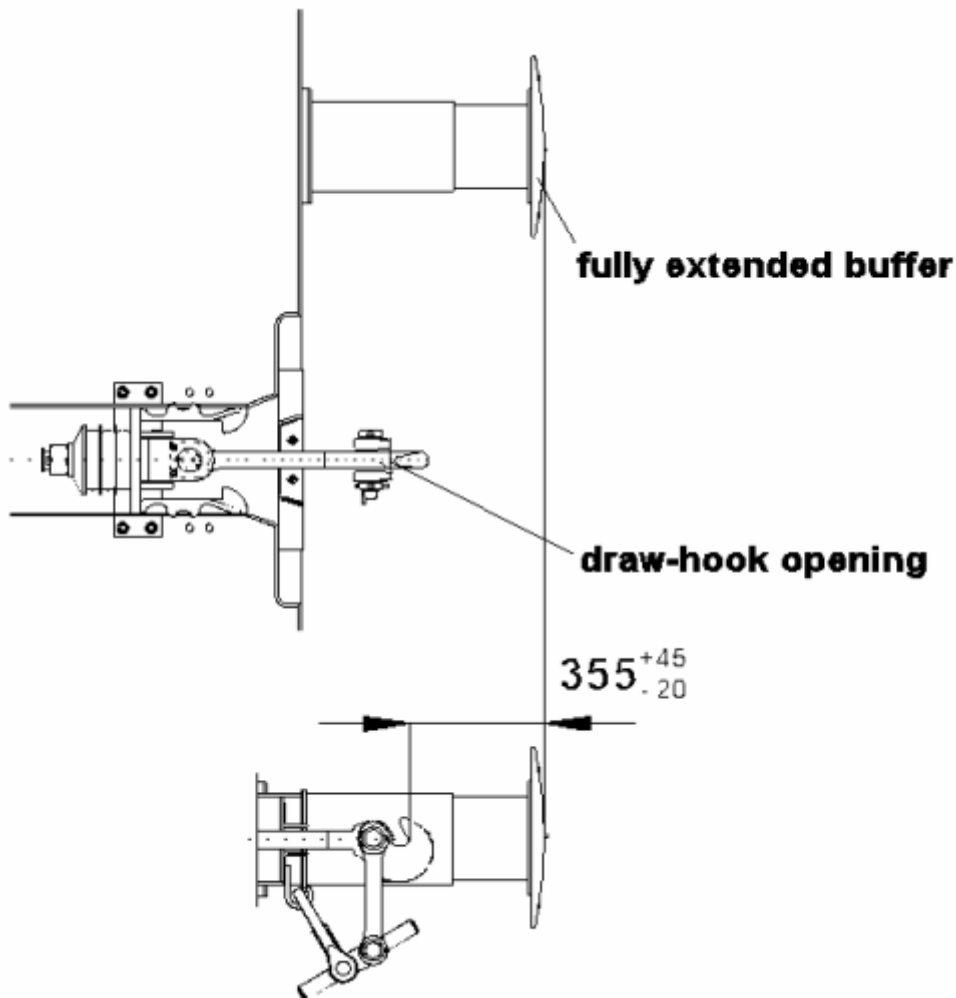

Units designed for 1435 mm and 1520 mm or 1435 mm and 1524 mm, or 1435 mm and 1668 mm gauge network(s), equipped with manual coupling and “UIC” pneumatic brake system, shall be compatible with both,

- the interface requirements for “End Coupling” mentioned before, and
- specific buffer layouts related to broad gauge networks.

In order to provide this full compatibility, it is permitted to have a different value of the distance between buffer centrelines, 1790 mm (Finland) and 1850 mm (Portugal and Spain) taking into account clause 6.2.3.1 of EN 15551:2009+A1:2010.

2. UIC footsteps and handrails

The unit shall be equipped with footsteps and handrails in accordance with chapter 4 of ERA technical document ERA/TD/2012-04/INT version 1.0 of 04.06.2012 published on the ERA website (<http://www.era.europa.eu>).

3. Ability to be hump shunted

In addition to the requirements of point 4.2.2.2 the unit shall be assessed in accordance with clause 8 of EN 12663-2:2010 and classified in Category F I in accordance with clause 5.1 of EN 12663-2:2010 with the following exception: for units designed to carry motor vehicles or combined transport units without long stroke shock absorbers the Category F-II may be used. The requirements concerning the buffing tests in clause 8.2.5.1 of EN 12663-2:2010 apply.

4. Free space under lifting points

The unit shall comply with figure C.2 on the free space under the re-railing places for rerailing:

Fig. C.2

Free spaces under rerailing places

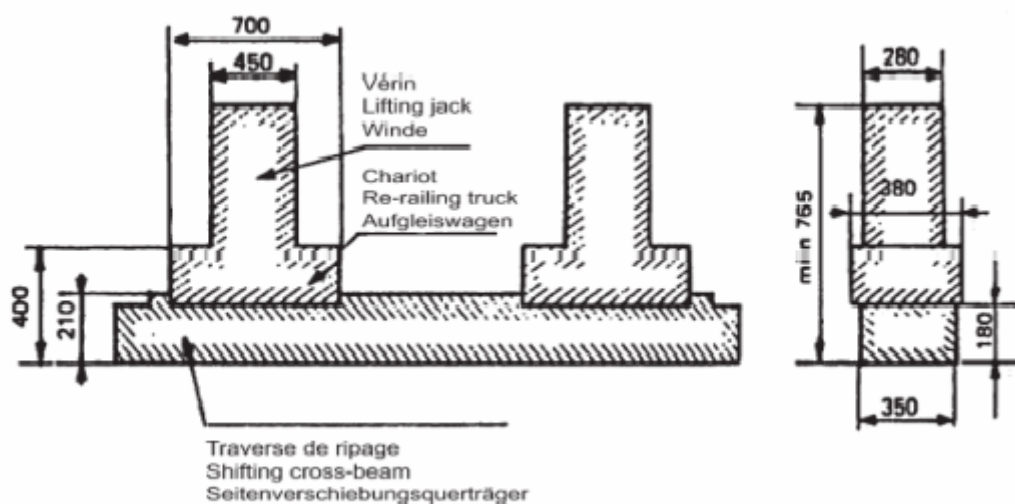

5. Marking of units

Markings of EN15877-1:2012 are required where applicable. The following are always applicable:

- 4.5.2 Gauge marking
- 4.5.3 Vehicle Tare Weight
- 4.5.4 Vehicle load table
- 4.5.5 Sign for length over buffers

- 4.5.12 Table of Maintenance dates
- 4.5.14 Lifting and re-railing signs
- 4.5.23 Distances between end axles and bogie centres
- 4.5.29 Brake weight

Units compliant with all requirements set out in section 4.2, fulfilling all conditions set out in point 7.1.2 and all conditions set out in Appendix C may receive the marking “GE”.

Units compliant with all requirements set out in section 4.2, fulfilling all conditions in point 7.1.2 and the conditions set out in Appendix C but not those set out in Appendix C sections 3 and/or 6 and/or 7.b may receive the marking “CW”.

If the additional marking is used, it shall be inscribed on the unit as outlined in figure C.3.

Fig. C.3

The additional markings “GE” and “CW”



The letters shall be of the same font type as the TEN marking. The size of the letters shall be at least 100 mm high. The outer measures of the frame shall be at least 275 mm wide and 140 mm high, the frame shall be 7 mm thick.

The marking shall be located on the right hand side of the area containing the European Vehicle Number and the TEN marking.

6. G1 gauge

The reference contour with which the unit complies with shall be G1 and G11 determined as defined in point 4.2.3.1.

7. Compliance with core TSI regarding train detection systems

(a) The unit shall be compatible with the train detection systems based on track circuits, on axle counters and on loop equipment as specified in clauses 4.2.3.3(a), 4.2.3.3(b) and 4.2.3.3(c).

(b) The distance between two adjacent axles of the unit shall not exceed 17500 mm.

8. Tests concerning longitudinal compressive forces

The verification of safe running under longitudinal compressive forces shall be in accordance with EN15839:2012.

9. UIC brake

The brake system shall be compatible with vehicles equipped with UIC approved brake systems. The brake system of a unit is compatible with the UIC brake system if it fulfils the following requirements:

- (a) The unit shall be equipped with a pneumatic brake pipe with an inner diameter of 32 mm.
- (b) Brake modes have different brake application and release times and specific brake weight percentage.
- (c) Every unit shall be fitted with a brake system having at least brake modes G and P. The brake modes G and P shall be assessed in accordance with UIC 540:2006.
- (d) The minimum braking performance for brake-modes G and P shall be in accordance with table C.3.
- (e) If a unit is equipped with a brake system having in addition further brake modes the assessment procedure as described in point 4.2.4.3.2.1 shall be carried out for these additional brake modes. The brake application time of the P brake mode in accordance with UIC 540:2006 are also valid for further brake modes.
- (f) The energy storage has to be designed in such way that after a brake application with the maximum brake cylinder pressure and the maximum unit specific brake cylinder stroke at any load state the pressure in the auxiliary reservoir must be at least 0,3 bar more than the brake cylinder pressure without the addition of any further energy. Details for standardised air reservoirs are set out in EN 286-3:1994 (steel) and EN 286-4:1994 (aluminium).
- (g) The pneumatic energy of the brake system shall not be used for other applications different than those related to braking purposes.
- (h) The distributor and distributor isolating device shall be in accordance with EN 15355:2008+A1:2010. At least one distributor shall be installed per 31m unit length.
- (i) The pneumatic half coupling:
 - (i) The interface of the brake pipe shall be in accordance with EN 15807:2011.
 - (ii) The opening of the automatic air brake coupling head shall face the left when looking at the end of the vehicle.

- (iii) The opening of the main reservoir coupling head shall face the right when looking at the end of the unit.
- (iv) The end cocks shall be in accordance with EN 14601:2005+A1:2010.
- (j) The brake mode switching device shall be in accordance with UIC 541-1:2010 Appendix E.
- (k) Brake block holders shall be in accordance with UIC leaflet 542:2010.
- (l) If the brake system requires brake blocks acting on the wheel tread, only the brake blocks listed in Appendix G shall be used.
- (m) Slack adjusters shall be in accordance with ERA technical document ERA/TD/2012-05/INT version 1.0 of 04.06.2012 published on the ERA website (<http://www.era.europa.eu>).
- (n) If the unit is equipped with a wheel slide protection system (WSP) it shall be in accordance with EN 15595:2009+A1:2011.

Table C.3

Minimum braking performance for brake modes G and P

| Braking mode | unit type | Command Equipment | Load status | Requirement for running speed at 100km/h | | Requirement for running speed at 120km/h | |
|------------------|---------------------|---|--|---|---|--|---|
| | | | | Maximum braking distance | Minimum braking distance | Maximum braking distance | Minimum braking distance |
| Braking mode "P" | All | All | Empty | $S_{max} = 480m$ $\lambda_{min} = 100\%$ ⁽¹⁾ $a_{min} = 0,91m/s^2$ ⁽¹⁾ | $S_{min} = 390m$, $\lambda_{max} = 125\%$, (130%)*, $a_{max} = 1,15m/s^2$ | $S_{max} = 700m$ $\lambda_{min} = 100\%$ $a_{min} = 0,88m/s^2$ | $S_{min} = 580m$, $\lambda_{max} = 125\%$, (130%)*, $a_{max} = 1,08m/s^2$ |
| | "S1" ⁽²⁾ | Changeover ⁽⁹⁾ | Inter-mediate | $S_{max} = 810m$ $\lambda_{min} = 55\%$ $a_{min} = 0,51m/s^2$ | $S_{min} = 390m$, $\lambda_{max} = 125\%$, $a_{max} = 1,15m/s^2$ | | |
| | | | Loaded | $S_{max} = 700m$ $\lambda_{min} = 65\%$ $a_{min} = 0,60m/s^2$ | $S_{min} = \text{Max} [(S = 480m,$ $\lambda_{max} = 100\%$, $a_{max} =$ $0,91m/s^2)$, (S obtained with a mean retardation force of 16,5 kN per axle)] ⁽⁵⁾ . | | |
| | "S2" ⁽³⁾ | load Variable Relay ⁽¹⁰⁾ | Loaded | $S_{max} = 700m$ $\lambda_{min} = 65\%$ $a_{min} = 0,60m/s^2$ | $S_{min} = \text{Max} [(S = 480m,$ $\lambda_{max} = 100\%$, $a_{max} =$ $0,91m/s^2)$, (S obtained with a mean retardation force of 16,5 kN per axle)] ⁽⁶⁾ . | | |
| | "S3" ⁽⁴⁾ | Variable load Relay ⁽¹⁰⁾ | Loaded (18t per axle for brake blocks) | | | | |
| Braking mode "G" | | | | There shall be no separate assessment of the braking performance of units in position G. A unit's braked weight in position G is the result of the braked weight in position P (see UIC 544-1:2012) | | | |

*only for two stage load brake (changeover command) and P10 (cast iron blocks with 10 % phosphor)- or LL-brake blocks

(1) "a" = ((Speed (Km/h))/3,6)^2/(2x(S-((Te)x(Speed (Km/h)/3,6))))), with Te=2sec. Distance calculation EN 14531-1:2005 section 5.11

(2) a unit "S1" is a unit with empty/load device. Maximum load per axle is 22,5 t.

(3) a unit “S2” is a unit with a variable load relay. Maximum load per axle is 22,5 t.

(4) a unit “SS” shall be equipped with a variable load relay. Maximum load per axle is 22,5 t.

(5) The maximum mean retardation force admitted (for running speed at 100km/h) is $18 \times 0,91 = 16,5$ kN/axle. This value comes from the maximum braking energy input permitted on a clasp braked wheel with a nominal new diameter in the range of [920 mm; 1 000 mm] during braking (the brake weight shall be limited to 18 tonnes/axle).

(6) The maximum mean retardation force admitted (for running speed at 100km/h) is $18 \times 0,91 = 16,5$ kN/axle. This value comes from the maximum braking energy input permitted on a clasp braked wheel with a nominal new diameter in the range of [920 mm; 1 000 mm] during braking (the brake weight shall be limited to 18 tonnes/axle). Usually a unit, with $V_{max} = 100$ km/h and fitted with a variable relay is designed to obtain $\lambda = 100\%$ up to 14.5 t/axle.

(7) The maximum mean retardation force admitted (for running speed at 120km/h) is $18 \times 0,88 = 16$ kN/axle. This value comes from the maximum braking energy input permitted on a clasp braked wheel with a nominal new diameter in the range of [920 mm; 1 000 mm] during braking (the brake weight shall be limited to 18 tonnes). The mass/axle is limited to 20 t/axle and the corresponding λ is 90%. If it is required $\lambda > 100\%$ with mass/axle > 18 t then it is necessary to consider another kind of brake.

(8) λ must not exceed 125%, considering for brake only on wheels (brake blocks), the maximum mean retardation force admitted of 16 kN/axle (for running speed at 120km/h).

(9) Changeover in accordance with EN 15624:2008+A1:2010.

(10) Variable load relay in accordance with EN 15611:2008+A1:2010 in combination with variable load sensing device in accordance with EN 15625:2008+A1:2010.

10. Location of parking brake handles

If a unit is equipped with a parking brake the location of its operating handle or operating wheel shall be:

- on both sides of the unit if it is operated from the ground or
- on a platform, that can be accessed from both sides of the unit.

The operation from the ground shall be done by wheel.

11. Temperature ranges for air reservoirs, hoses and grease

The following requirements are deemed to comply with the range T1 indicated in point 4.2.5.

- Air reservoirs shall be designed for the temperature range of -40°C to $+100^{\circ}\text{C}$.
- Brake cylinders and brake couplings shall be designed for the temperature range of -40°C to $+70^{\circ}\text{C}$.
- Hoses for air brakes and air supply shall be specified for the temperatures range -40°C to $+70^{\circ}\text{C}$.
- The grease for the lubrication of roller bearing shall be specified for ambient temperatures down to -20°C .

12. Welding

Welding shall be carried out in accordance with EN 15085-1-5:2007.

13. Track gauge

The unit shall be compatible with the 1435 mm track gauge.

14. Specific brake thermal capacity

The brake system shall resist a thermal load equivalent to the suggested reference case in point 4.2.4.3.3.

Concerning the use of wheel tread brake systems this condition is deemed to be fulfilled, if the brake block

- is listed in Appendix G and
- is used within its area of use as described in Appendix G

and if the wheel

- is assessed in accordance with point 6.1.2.3 and
- fulfils the conditions of section 15 of Appendix C.

15. Specific product properties concerning the wheel

The wheels shall be in accordance with EN 13262:2004+A1:2008+A2:2011 and EN 13979-1:2003+A1:2009+A2:2011. The thermal mechanical type test required in point 6.1.2.3 shall be carried out in accordance with table C.4 when the complete brake system is acting directly on the wheel tread.

Table C.4

Conditions for the thermal mechanical type test

| Wheel diameter range [mm] | 1000 - 920 | 920 - 840 | 840 - 760 | 760 - 680 |
|--------------------------------------|-------------------|------------------|------------------|------------------|
| Standard power value | 50 kW | 50 kW | 42,5 kW | 38 kW |
| Application time | 45 min | 45 min | 45 min | 45 min |
| Running speed | 60 km/h | 60 km/h | 60 km/h | 60 km/h |

16. Tow hooks

Units shall be provided with tow hooks, each one being fixed to the side of the unit underframe in accordance with clause 1.4 of UIC 535-2:2006.

17. Protective devices on protruding parts

To ensure the safety of staff, protruding (e.g. angular or pointed) parts of the unit located up to 2 m above rail level or above passageways, working surfaces or tow hooks which are liable to cause accidents, shall be fitted with protective devices as described in clause 1.3 of UIC 535-2:2006

18. Label holders and attachment devices for rear end signal

All units shall be equipped with a label holder in accordance with clause 1 of UIC 575:1995 and at both ends with attachment devices as set out in point 4.2.6.3.

Appendix D: Standards or normative documents referred to in this TSI

| TSI | | Standard | |
|--|--------------|--|----------|
| Characteristics to be assessed | | References to mandatory Standard | Clauses |
| Structure and mechanical part | 4.2.2 | | |
| Strength of unit | 4.2.2.2 | EN12663-2:2010 | 5 |
| | | EN15877-1:2012 | 4.5.13 |
| | 6.2.2.1 | EN12663-2:2010 | 6, 7 |
| Vehicle track interaction and gauging | 4.2.3 | | |
| Gauging | 4.2.3.1 | EN 15273-2:2009 | all |
| Compatibility with load carrying capacity of lines | 4.2.3.2 | EN 15528:2008 | 6.1, 6.2 |
| Axle bearing condition monitoring | 4.2.3.4 | EN 15437-1:2009 | 5.1, 5.2 |
| Safety against derailment running on twisted track | 4.2.3.5.1 | - | - |
| | 6.2.2.2 | EN 14363:2005 | 4.1 |
| | | EN 15839:2012 | 4.2 |
| Running dynamic behaviour | 4.2.3.5.2 | EN 14363:2005 | 5 |
| | 6.2.2.3 | EN 14363:2005 | 5 |
| | | EN 15687:2010 | 5.3.2.2 |
| | | EN 15827:2011 | 9.3 |
| | 6.1.2.1 | Content of prEN 16235 included in Appendix B of this TSI | all |
| Running gear | 4.2.3.6 | - | - |
| | 6.1.2. 1 | EN 13749:2011 | 6.2 |
| | | Content of prEN 16235 included in Appendix B of this TSI | all |
| Structural design of bogie frame | 4.2.3.6.1 | EN 13749:2011 | 6.2 |
| | 6.1.2. 1 | EN 13749:2011 | 6.2 |
| Characteristics of wheelsets | 4.2.3.6.2 | - | - |
| | 6.1.2. 2 | EN 13260:2009+A1:2010 | 3.2.1 |
| Characteristics of wheels | 4.2.3.6.3 | - | - |

| TSI | | Standard | |
|--|--------------|---|------------|
| Characteristics to be assessed | | References to mandatory Standard | Clauses |
| | 6.1.2.3 | EN 13979-1:2003+A1:2009 +A2:2011 | 7, 6.2 |
| Characteristics of axles | 4.2.3.6.4 | - | - |
| | 6.1.2. 4 | EN 13103:2009 | 4, 5, 6, 7 |
| Axle boxes / bearings | 4.2.3.6.5 | - | - |
| | 6.2.2.4 | EN 12082:2007+A1:2010 | 6 |
| Running gear for manual change of wheelsets | 4.2.3.6.7 | - | - |
| | 6.2.2.5 | UIC 430-1:2006 | Ann. B, H |
| | | UIC 430-3:1995 | Ann. 7 |
| Brake | 4.2.4 | | |
| In-service brake | 4.2.4.3.2.1 | EN 14531-6:2009 | all |
| | | UIC 544-1:2012 | all |
| Parking brake | 4.2.4.3.2.2 | EN 14531-6:2009 | 6 |
| | | EN15877-1:2012 | 4.5.25 |
| Environmental conditions | 4.2.5 | | |
| Environmental conditions | 4.2.5 | EN 50125-1:1999 | 4.7 |
| | 6.2.2.7 | - | - |
| System protection | 4.2.6 | | |
| Fire safety - barriers | 4.2.6.1.2.1 | - | - |
| | 6.2.2.8.1 | EN 1363-1:1999 | all |
| Fire safety - materials | 4.2.6.1.2.2 | - | - |
| | 6.2.2.8.2 | ISO 5658-2:2006/Am1:2011 EN 13501-1:2007+A1:2009 | all all |
| Fire safety - cables | 6.2.2.8.3 | EN 50355:2003 | all |
| | | EN 50343:2003 | all |
| Fire safety | 6.2.2.8.4 | TS 45545-7:2009 | all |
| Protection against el. hazard – indirect contact | 4.2.6.2.2.1 | EN 50153:2002 | 6.4 |

| TSI | | Standard | |
|--|-------------|---|----------------|
| Characteristics to be assessed | | References to mandatory Standard | Clauses |
| Protection against el. hazard – direct contact | 4.2.6.2.2.2 | EN 50153:2002 | 5 |
| Attachment devices for rear-end signals | 4.2.6.3 | ERA technical document ERA/TD/2012-04/INT version 1.0 of 04.06.2012 | Chapter 1 |

| Additional optional conditions for units | App. C | Standard / UIC leaflet | |
|--|--------|---|---------------------|
| Manual coupling system | C.1 | EN 15566:2009+A1:2010 | all |
| | | EN 15551:2009+A1:2010 | 6.2, 6.3.2 |
| | | ERA technical document ERA/TD/2012-04/INT version 1.0 of 04.06.2012 | Chapters 2 and 3 |
| | | EN15877-1:2012 | Figure 75 |
| UIC footsteps and handrails | C.2 | ERA technical document ERA/TD/2012-04/INT version 1.0 of 04.06.2012 | Chapter 4 |
| Ability to be hump shunted | C.3 | EN 12663-2:2010 | 5, 8 |
| Marking of units (RIV) | C.5 | EN15877-1:2012 | all |
| Tests concerning long. compressive forces | C.8 | EN 15839:2012 | all |
| UIC brake | C.9 | EN 15355:2008+A1:2010 | all |
| | | EN 15611:2008+A1:2010 | all |
| | | UIC 540:2006 | all |
| | | EN 14531-1:2005 | 5.11 |
| | | EN 15624:2008+A1:2010 | all |
| | | EN 15625:2008+A1:2010 | all |
| | | EN 286-3:1994 | all |
| | | EN 286-4:1994 | all |
| | | EN 15807:2011 | all |
| | | EN 14601:2005+A1:2010 | all |
| | | UIC 541-1:2010 | Ann. E |
| | | UIC leaflet 542:2010 | all |
| | | ERA technical document ERA/TD/2012-05/INT version 1.0 of 04.06.2012 | all |
| EN 15595:2009+A1:2011 | all | | |
| Welding | C.12 | EN 15085-1-5:2007 | all |
| | | | |
| Specific product properties concerning the wheel | C.15 | EN 13262: 2004 +A1:2008+A2:2011 | all |
| | | EN 13979-1:2003 +A1:2009+A2:2011 | all |

| | | | |
|--|------|----------------|-----|
| Tow hooks | C.16 | UIC 535-2:2006 | 1.4 |
| Protective devices on protruding parts | C.17 | UIC 535-2:2006 | 1.3 |
| Lable holders and attachment devices for rear end signal | C.18 | UIC 575:1995 | 1 |

Appendix E: Rear-end signal

1. Lamps

The colour of tail lamps shall be in accordance with clause 5.5.3 of EN 15153-1:2010.

The lamp shall display a luminous area of at least 170 mm diameter. The reflector system shall be designed to display a lighting strength of at least 15 candela of red light along the axis of the lighting surface for an angle of opening of 15° horizontally and 5° vertically. The intensity must be at least 7.5 candela of red light.

The lamp shall be suitable to be attached to units complying with the attachment devices and the clearance set out in point 4.2.6.3. The lamp shall be equipped with:

- a switch (on/off)
- a warning light which indicates the battery status.

2. Reflective plates

The reflective plates shall be suitable to be attached to units complying with the attachment devices and the clearance set out in point 4.2.6.3. The reflective section of the plates shall be at least 150 by at least 200 mm as illustrated in figure E.1. The side triangles shall be white, the top and the bottom triangles shall be red. The plate shall be retro-reflective in accordance with EN 12899-1:2007 Class Ref. 2.

Fig. E.1

Reflective plate

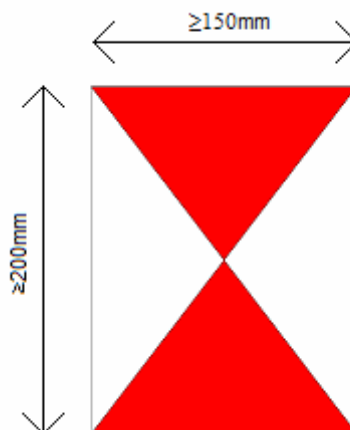

Appendix F: Assessment assigned to the production phases

Table F.1

Assessment assigned to the production phases

| Characteristics to be assessed, as specified in section 4.2 | | Design and development phase | | Production phase | Particular assessment procedure |
|---|-------------|------------------------------|-------------------------|------------------|---------------------------------|
| | | Design review | Type Test | Routine Test | |
| Element of the Rolling Stock sub-system | Point | | | | Point |
| Structure and mechanical part | | 4.2.2 | | | |
| End coupling | 4.2.2.1.1 | X | n.a. | n.a. | - |
| Inner coupling | 4.2.2.1.2 | X | n.a. | n.a. | - |
| Strength of unit | 4.2.2.2 | X | X | n.a. | 6.2.2.1 |
| Integrity of the unit | 4.2.2.3 | X | n.a. | n.a. | - |
| Vehicle track interaction and gauging | | 4.2.3 | | | |
| Gauging | 4.2.3.1 | X | n.a. | n.a. | - |
| Compatibility with load carrying capacity of lines | 4.2.3.2 | X | X | n.a. | - |
| Compatibility with train detection systems | 4.2.3.3 | X | X | n.a. | - |
| Axle bearing condition monitoring | 4.2.3.4 | X | X | n.a. | - |
| Safety against derailment running on twisted track | 4.2.3.5.1 | X | X | n.a. | 6.2.2.2 |
| Running dynamic behaviour | 4.2.3.5.2 | X | X | n.a. | 6.1.2.1 / 6.2.2.3 |
| Structural design of bogie frame | 4.2.3.6.1 | X | X | n.a. | 6.1.2.1 |
| Characteristics of wheelsets | 4.2.3.6.2 | X | X | X | 6.1.2.2 |
| Characteristics of wheels | 4.2.3.6.3 | X | X | X | 6.1.2.3 |
| Characteristics of axles | 4.2.3.6.4 | X | X | X | 6.1.2.4 |
| Axle boxes / bearings | 4.2.3.6.5 | X | X | X | 6.2.2.4 |
| Variable gauge wheelsets | 4.2.3.6.6 | open | open | open | open |
| Running gear for manual change of wheelsets | 4.2.3.6.7 | X | X | n.a. | 6.2.2.5 |
| Brake | | 4.2.4 | | | |
| Safety requirements | 4.2.4.2 | X | n.a. | n.a. | - |
| Functional and technical requirements | 4.2.4.3 | X | X | n.a. | - |
| In-service brake | 4.2.4.3.2.1 | X | X | n.a. | - |
| Parking brake | 4.2.4.3.2.2 | X | n.a. | n.a. | - |
| Thermal capacity | 4.2.4.3.3 | X | X | n.a. | 6.2.2.6 |
| Wheel slide protection (WSP) | 4.2.4.3.4 | X | X | n.a. | - |
| Environmental conditions | | 4.2.5 | | | |
| Environmental conditions | 4.2.5 | X | n.a. / X ⁽¹⁾ | n.a. | 6.2.2.7 |
| ⁽¹⁾ Type test if and as defined by the applicant | | | | | |
| System protection | | 4.2.6 | | | |
| Fire safety | 4.2.6.1 | X | X | n.a. | 6.2.2.8 |
| Protection against electric hazard | 4.2.6.2 | X | X | n.a. | - |
| Attachment devices for rear end signal | 4.2.6.3 | X | X | n.a. | - |

Appendix G: list of fully approved composite brake blocks for international transport

This Appendix is published on the ERA website (<http://www.era.europa.eu>).