



Council of the
European Union

Brussels, 10 December 2014
(OR. en)

16758/14
ADD 3

AGRI 790
ENT 295
MI 990
DELECT 237

COVER NOTE

From: Secretary-General of the European Commission,
signed by Mr Jordi AYET PUIGARNAU, Director

date of receipt: 8 December 2014

To: Mr Uwe CORSEPIUS, Secretary-General of the Council of the European
Union

No. Cion doc.: C(2014) 9198 final ANNEXES 17 TO 34

Subject: ANNEXES to the Commission Delegated Regulation (EU) No .../... of XXX
supplementing Regulation (EU) No 167/2013 of the European Parliament
and of the Council with regard to vehicle functional safety requirements for
the approval of agricultural and forestry vehicles

Delegations will find attached document C(2014) 9198 final ANNEXES 17 TO 34.

Encl.: C(2014) 9198 final ANNEXES 17 TO 34



Brussels, 8.12.2014
C(2014) 9198 final

ANNEXES 17 to 34

ANNEXES

to the

Commission Delegated Regulation (EU) No .../... of XXX

supplementing Regulation (EU) No 167/2013 of the European Parliament and of the Council with regard to vehicle functional safety requirements for the approval of agricultural and forestry vehicles

ANNEX XVII
Requirements on heating systems

- 1. Requirements for all T- and C-category vehicles, where such system is fitted**
- 1.1. Tractors with enclosed driver compartments shall be fitted with a heating system which complies with this Annex.

Tractors with enclosed driver compartments may be fitted with air conditioning systems; where fitted, such systems shall comply with this Annex.
- 1.2. The heating system, in combination with the enclosed compartment ventilation, shall be able to defrost and demist the windscreen.

Heating and cooling systems shall be tested in accordance with ISO 14269-2:1997, sections 8 and 9, respectively. Test reports shall be included into the information document.
- 1.3. The manufacturer may choose whether to comply with either the requirements set out in this Annex on heating system or with the requirements for N-category vehicles set out in UNECE Regulation No 122 as referenced in Annex I.

ANNEX XVIII
Requirements on devices to prevent unauthorised use

1. Requirements for all T- and C-category vehicles

Manufacturers may choose to apply either this point or point 2.

1.1. Starting and stopping the engine

1.1.1. A means shall be provided to enable prevention of inadvertent and/or unauthorized starting of the engine. Examples of such means include but are not limited to:

- an ignition or start switch with a removable key;
- a lockable cab;
- a lockable cover over the ignition or start switch;
- a security ignition or starting lock (e.g. key card activated);
- a lockable battery disconnect switch.

2. Requirements for all T- and C-category vehicles according to UNECE regulations or international standards

2.1. For vehicles which are fitted with handlebars, all the relevant requirements of UNECE Regulation No 62, as referenced in Annex I, shall apply.

2.2. For vehicles which are not fitted with handlebars, manufacturers shall apply all the relevant requirements as prescribed for vehicle category N2 in points 2, 5 except point 5.6, 6.2 and 6.3, of UNECE Regulation No 18, as referenced in Annex I to this Regulation or the requirements of appropriate standards on programmable electronic devices in order to prevent unauthorised use, should such standards exist from 1 January 2018.

3. Requirements for all S-category vehicles and interchangeable towed equipment falling in R-category due to technically permissible maximum laden mass to the unladen mass equal to or greater than 3,0

At least one device shall be installed on a S-category vehicle or interchangeable towed equipment falling in R-category due to technically permissible maximum laden mass to the unladen mass equal to or greater than 3,0 to enable prevention of inadvertent or unauthorized use of such vehicles.

Such device may consist in the following:

- a lockable cover over the coupling device;
- a chain and padlock through the ring of the coupling device;
- a wheel clamp;
- a padlock in a hole in the sector of the park brake;

The Operator's Manual shall contain information on the use of the devices installed on the vehicle.

ANNEX XIX
Requirements on registration plates

1. Shape and dimensions of the space for mounting rear registration plates

The space for mounting shall comprise a flat or virtually flat rectangular surface with the following minimum dimensions:

either

width: 520 mm

height: 120 mm

or

width: 255 mm

height: 165 mm.

2. Location of the space for mounting and the fixing of the plates

The space for mounting shall be such that, after correct fixing, the plates shall have the following characteristics:

2.1. Lateral position of the plate

The centre of the plate shall not be further to the right than the plane of symmetry of the vehicle. The left lateral edge of the plate shall not be further to the left than the vertical plane parallel to the plane of symmetry of the vehicle and tangent to the point where the cross section of the vehicle is at its widest.

2.2. Position of the plate in relation to the longitudinal plane of symmetry of the vehicle

The plate shall be perpendicular or practically perpendicular to the plane of symmetry of the vehicle.

2.3. Position of the plate in relation to the vertical plane

The plate shall be vertical within a tolerance of 5°. However, where the shape of the vehicle so requires, it may be inclined to the vertical:

2.3.1. at not more than 30° when the surface bearing the registration number is inclined upwards, provided that the height of the upper edge of the plate is not more than 1.2 metres from the ground.

2.3.2. at not more than 15° when the surface bearing the registration number is inclined downwards, provided that the height of the upper edge of the plate is more than 1.2 metres from the ground.

2.4. Height of the plate from the ground

The height of the lower edge of the plate above ground shall not be less than 0.3 metres; the

height of the upper edge of the plate above ground shall not exceed 4 metres.

2.5. Determination of the height of the plate from the ground

The heights given in points 2.3 and 2.4 shall be measured with the vehicle unladen.

2.6. Geometrical visibility:

2.6.1. The plate shall be visible in the whole space within the following four planes:

— the two vertical planes touching the two lateral edges of the plate and forming an angle measured outwards to the left and to the right of the plate of 30° to the longitudinal median plane of the vehicle,

— the plane touching the upper edge of the plate and forming an angle measured upwards of 15° to the horizontal,

— the horizontal plane through the lower edge of the plate.

2.6.2. No structural element, even when fully transparent, shall be located in the space described above.

ANNEX XX
Requirements on statutory plates and markings

1. Definitions

For the purposes of this Annex:

- 1.1. 'Statutory plate' means the plate that the manufacturer shall affix to each vehicle manufactured in conformity with the approved type as set out in Article 34 of Regulation (EU) No 167/2013 and it shall have the appropriate marking in accordance with this Annex.
- 1.2. 'Statutory markings' means any mandatory markings together with the type-approval mark set out in Article 34 of Regulation (EU) No 167/2013 which, in accordance with this Annex, shall be affixed to vehicles, components or separate technical units when they are manufactured in conformity with the approved type or for its identification during the type approval processes.

2. General

- 2.1. All agricultural or forestry vehicles shall be provided with the plate and inscriptions described in the following points. The plate and inscriptions are attached either by the manufacturer or by his authorised representative.
- 2.2. All components or separate technical units conforming to a type approved pursuant to Regulation (EU) No 167/2013 shall bear an EU type-approval mark described in point 6 or a mark according to Article 34(2) of Regulation (EU) No 167/2013 set out in Article 68(h) or Article 34(3), respectively, of Regulation (EU) No 167/2013.

3. Statutory plate

- 3.1. A statutory plate, modelled as set out in Article 34(3) of Regulation (EU) No 167/2013, shall be firmly attached in a conspicuous and readily accessible position on a part normally not subject to replacement during normal use, regular maintenance or repair (e.g. due to accident damage). It shall show clearly and indelibly the information specified in the model for the EU type-approval mark set out in Article 34(3) or in Article 68(h) of Regulation (EU) No 167/2013.
- 3.2. The manufacturer may give additional information below or to the side of the prescribed inscriptions, outside a clearly marked rectangle enclosing only the information prescribed in accordance with Article 34(1) and (3) of Regulation (EU) No 167/2013.

4. Vehicle Identification Number

The vehicle identification number is a fixed combination of characters unequivocally attributed to a particular vehicle by the manufacturer. Its purpose is to ensure that every vehicle, and in particular its type, can be clearly identified over a period of 30 years through the intermediary of the manufacturer, without a need for further reference.

The identification number shall comply with the following requirements:

- 4.1. The VIN shall be marked on the statutory plate, as well as on the chassis, frame or a similar structure of the vehicle when the vehicle leaves the production line.
- 4.2. It shall wherever possible be entered on a single line.

- 4.3. It shall be marked on the chassis or other similar structure, on the front right-hand side of the vehicle.
- 4.4. It shall be hammered, punched, etched or laser-engraved directly onto an easily accessible part, preferably on the front right side of the vehicle in a way which avoids obliteration, alteration and removal.

5. Characters

The characters that shall be used for the markings of points 3 and 4 are specified in the model for the EU type-approval mark set out in Article 68(h) of Regulation (EU) No 167/2013.

6. Marking requirements for components and separate technical units

Every separate technical unit or component, conforming to a type in respect of which EU separate technical unit or component type-approval has been granted in accordance with Chapter V of Regulation (EU) No 167/2013, shall bear an EU separate technical unit or component type-approval mark, pursuant to Article 34(2) and (3) of Regulation (EU) No 167/2013. The markings shall be visible when installed on the vehicle without the need to remove any parts with the use of tools and shall be durably affixed (e.g. stamped, etched, laser inscribed, self-destructing adhesive label).

ANNEX XXI
Requirements on dimensions and trailer masses

1. Definitions

For the purposes of this Annex:

1.1. 'Length of the vehicle' means:

— the length of the vehicle measured between the vertical planes at right angles to the longitudinal axis of the vehicle and passing the outermost points thereof, but excluding:

- all mirrors,
- all starting handles,
- all front or lateral position (side) lamps.

1.2. 'Width of the vehicle' means:

— the width of the vehicle measured between the vertical planes parallel to the longitudinal axis of the vehicle and passing through the outermost points thereof, but excluding:

- any mirrors,
- any direction indicators,
- any front, lateral or rear position (side) lamps and any parking lamps,
- any folding components such as lift-up footrests and flexible mud-flaps.

1.3. 'Height of the vehicle' means the vertical distance between the ground and the point on the vehicle the greatest distance from the ground, excluding the aerial. When this height is determined, the vehicle must be fitted with new tyres having the greatest rolling radius, expressed by the speed radius index, specified by their manufacturer;

1.4. 'Permissible towable mass' means the mass which a type of tractor may tow;

1.5. 'Technically permissible towable mass(es)' means one of the following:

- (a) unbraked towable mass,
- (b) towable mass with inertia braking,
- (c) towable mass fitted with hydraulic or pneumatic braking.

Requirements

Vehicles may not exceed the dimensions and masses laid down below:

2. Dimensions

The measurements intended to check these dimensions shall be carried out as follows:

- with unladen mass of vehicle in running order,

- on a flat horizontal surface,
- with the vehicle stationary and, if applicable, the engine switched off,
- with the new tyres at the normal pressure recommended by the manufacturer,
- with doors and windows closed, if applicable,
- with the steering wheel in the straight-ahead position, if applicable,
- without any detachable agricultural or forestry implement attached to the vehicle and that can be detached without special tools.

2.1. The maximum dimensions of any vehicle of category T, C or R are as follows:

2.1.1. length: 12 m;

2.1.2. width: 2.55 m (ignoring the deflected part of the tyre walls at the point of contact with the ground);

2.1.3. height: 4 m.

2.2. The maximum dimensions of any vehicle of category S are as follows:

2.2.1. length: 12 m;

2.2.2. width: 3 m (ignoring the deflected part of the tyre walls at the point of contact with the ground);

2.2.3. height: 4 m.

3. Permissible towable mass

3.1. The permissible towable mass may consist of one or more trailers towed or agricultural or forestry implements. A distinction is drawn between the technically permissible towable mass stated by the manufacturer and the permissible towable mass as laid down in point 3.2 below.

3.2. The permissible towable mass shall not exceed:

3.2.1. the technically permissible towable mass, stated by the tractor manufacturer, taking into account the requirements concerning the tractor in Annex XXXIV;

3.2.2. the towable mass of the mechanical coupling(s) pursuant to their component type-approval(s) in accordance with this Regulation.

ANNEX XXII
Requirements on the maximum laden mass

1. Definitions

For the purposes of this Annex:

Definitions of ‘drawbar towed vehicle’ and ‘rigid drawbar towed vehicle’, in accordance with the requirements laid down on the basis of Article 17(2)(b) and (4) of Regulation (EU) No 167/2013, are valid for this Annex.

- 1.1. ‘Technically permissible maximum laden mass’ means the maximum mass allocated to a vehicle on the basis of its construction features and its design performances irrespective from the load capacity of the tyres or tracks.
- 1.2. ‘Technically permissible maximum mass per axle’ means the mass corresponding to the maximum permissible static vertical load transmitted to the ground by the wheels of the axle, on the basis of the construction features of the axle and of the vehicle and their design performances irrespective from the load capacity of the tyres or tracks.

2. Requirements

- 2.1. The technically permissible maximum laden mass as stated by the manufacturer shall be accepted by the type-approval authority as the maximum permissible laden mass provided that:
 - 2.1.1. the results of any tests which that administration makes, in particular those in respect of braking and steering, are satisfactory;
 - 2.1.2. the technically permissible maximum laden mass and the technically permissible maximum mass per axle depending on the vehicle category does not exceed the values given in Table 1.

Table 1

Maximum Permissible Laden Mass and Maximum Permissible Mass per Axle Depending on the Vehicle Category

Vehicle category	Number of axles	Maximum permissible mass (t)	Maximum permissible mass per axle	
			Driven axle (t)	Non-driven axle (t)
T1, T2, T4.1, T4.2	2	18 (laden)	11.5	10
	3	24 (laden)	11.5 ^(d)	10 ^(d)
T1	4 or more	32 (laden) ^(c)	11.5 ^(d)	10 ^(d)
T3	2 or 3	0.6 (unladen)	(a)	(a)

T4.3	2, 3 or 4	10 (laden)	(a)	(a)
C	N/A	32	N/A	N/A
R	1	N/A	11.5	10
	2	18 (laden)	11.5	(b)
	3	24 (laden)	11.5	(b)
	4 or more	32 (laden)	11.5	(b)
S	1	N/A	11.5	10
	2	18 (laden)	11.5	(b)
	3	24 (laden)	11.5	(b)
	4 or more	32 (laden)	11.5	(b)

(a) It is not necessary to establish an axle limit for vehicle categories T3 and T4,3, as they have by definition limitations on the maximum permissible laden and/or unladen mass.

(b) The corresponding value for the sum of the axle maximum permissible mass is the sum of the axle weights in Annex I, points 3.1 to 3.3, to Council Directive 96/53/EC¹.

(c) Where the driving axle is fitted with twin tyres and air suspension or suspension recognized as being equivalent within the European Union as defined in Annex II to Directive 96/53/EC, or where each driving axle is fitted with twin tyres and the maximum weight of each axle does not exceed 9.5t.

(d) The corresponding value for the sum of the axle maximum permissible mass is the sum of the axle weights in Annex I, point 3.5, to Directive 96/53/EC.

- 2.2. Whatever the state of loading of the tractor, the mass transmitted to the road by the wheels on the steering axle shall not be less than 20 % of the unladen mass of that tractor.
- 2.3. Sum of the technically permissible maximum masses per axle
- 2.3.1. For vehicles of categories T and C and of categories R and S, which do not impose any significant static vertical load on the tractor (drawbar towed vehicle), the sum of the maximum permissible masses per axle shall be equal to or higher than the maximum permissible laden mass of the vehicle.
- 2.3.2. For vehicles of categories R and S imposing a significant static vertical load on the tractor (rigid drawbar towed vehicle), the maximum permissible mass of the vehicle shall be considered to be the sum of the maximum permissible masses per axle and shall be applicable for type approval purposes.

¹ Council Directive 96/53/EC of 25 July 1996 laying down for certain road vehicles circulating within the Community the maximum authorized dimensions in national and international traffic and the maximum authorized weights in international traffic (OJ L 235, 17.9.1996, p. 59).

ANNEX XXIII
Requirements on ballast masses

Where the tractor is to be fitted with ballast weights in order to meet the other requirements of EU type-approval, those ballast weights shall be supplied by the manufacturer of the tractor, be intended for fitting, and bear the manufacturer's mark and a statement of their mass in kilograms to an accuracy of $\pm 5\%$. Front ballast weights that have been designed for frequent removal/fitting shall leave a safety clearance of at least 25 mm for the grab handles. The method of locating the ballast weights shall be such that any inadvertent separation is avoided (e.g. in the event of tractor rollover).

ANNEX XXIV
Requirements on the safety of electrical systems

1. Requirements for all T, C, R and S vehicles equipped with electrical systems

1.1. Electrical equipment

1.1.1. Electrical cables shall be protected if located in potentially abrasive contact with surfaces and shall be resistant to, or protected against, contact with lubricant or fuel. Electrical cables shall be located so that no portion is in contact with the exhaust system, moving parts or sharp edges.

1.1.2. Fuses or other overload protection devices shall be installed in all electrical circuits except for high amperage circuits such as the starter-motor circuit and high-tension spark ignition system. Electrical distribution of these devices between circuits shall prevent the possibility of cutting off all operator alert systems simultaneously.

2. Requirements on static electricity safety

Requirements on static electricity safety are the ones provided in point 3 of Annex XXV.

3. All-electric vehicles in categories T2, T3, C2 or C3 should comply, as far as is practicable, with the requirements of Annex IV of the Regulation (EU) No 3/2014.²

² Commission Delegated Regulation (EU) No 3/2014 of 24 October 2013 supplementing Regulation (EU) No 168/2013 of the European Parliament and of the Council with regard to vehicle functional safety requirements for the approval of two- or three-wheel vehicles and quadricycles (OJ L 7, p. 1, 10.01.2014)

ANNEX XXV
Requirements on fuel tanks

1. This Annex applies to tanks designed to contain the liquid fuel used primarily for the propulsion of the vehicle.

Fuel tanks shall be made so as to be corrosion resistant. They shall satisfy the leakage tests carried out by the manufacturer at a pressure equal to double the working pressure but in any event not less than 0.3 bar. Any excess pressure or any pressure exceeding the working pressure shall be automatically compensated by suitable devices (vents, safety valves etc.). The vents shall be designed in such a way as to prevent any fire risk. The fuel shall not escape through the fuel-tank cap or through the devices provided to compensate excess pressure even if the tank is completely overturned: a drip shall be tolerated.

2. Fuel tanks shall be installed in such a way as to be protected from the consequences of an impact to the front or to the rear of the tractor; there shall be no protruding parts, sharp edges etc. near the tanks.

The fuel supply pipework and the filler orifice shall be installed outside the cab.

3. **Requirements related to static electricity safety of the fuel tank**

The fuel tank and its accessory parts shall be designed and installed in the vehicle in such a way that any ignition hazard due to static electricity shall be avoided.

If necessary, measure(s) for charge dissipation shall be provided.

The manufacturer shall demonstrate to the Technical Service the measure(s) which guarantee the fulfilling of these requirements.

ANNEX XXVI
Requirements on rear protective structures

1. General

Vehicles of category R covered by this Regulation shall be designed so as to provide effective protection against underrunning from the rear by vehicles of categories M₁ and N₁³. They shall comply with the requirements of points 2 and 3, shall be granted a type-approval certificate set out in Article 68(c) of Regulation (EU) No 167/2013 and the EU type-approval mark shall be affixed to them as set out in Article 68(h) of Regulation (EU) No 167/2013.

2. Requirements

2.1. Vehicles of categories Ra and Rb shall be so constructed and/or equipped as to offer effective protection over their whole width against underrunning from the rear by a vehicle of categories M₁ and N₁.

2.1.1. The vehicle shall be tested under the following conditions:

- it shall be at rest on a level, flat, rigid and smooth surface,
- the front wheels shall be in the straight-ahead position,
- tyres shall be inflated to the pressure recommended by the vehicle manufacturer,
- the vehicle may, if necessary to achieve the test forces required, be restrained by any method specified by the vehicle manufacturer,

if the vehicle is equipped with hydropneumatic, hydraulic or pneumatic suspension or a device for automatic levelling according to load, it shall be tested with the suspension or device in the normal running condition specified by the manufacturer.

2.2. Any vehicle in one of the categories R1a, R1b, R2a or R2b shall be deemed to satisfy the condition set out in 2.1:

- if it satisfies the conditions set out in 2.3, or
- if the ground clearance of the rear part of the unladen vehicle does not exceed 55 cm over a width which is not shorter than that of the rear axle by more than 10 cm on either side (excluding any tyre bulging close to the ground).

Where there is more than one rear axle, the width to be considered is that of the widest.

This requirement shall be satisfied at least on a line at a distance of not more than 45 cm from the rear extremity of the vehicle.

2.3. Any vehicle in one of the categories R3a, R3b, R4a or R4b shall be deemed to satisfy the condition set out in 2.1 provided that:

- the vehicle is equipped with a special rear protective structure in accordance with the requirements of 2.4, or

³ As defined in Annex II Part A to Directive 2007/46/EC.

- the vehicle is so designed and/or equipped at the rear that, by virtue of their shape and characteristics, its component parts can be regarded as replacing the rear protective structure. Components whose combined function satisfies the requirements set out in 2.4 are considered to form a rear protective structure.

2.4. A device for protection against underrunning from the rear, hereinafter referred to as «device», generally consists of a cross-member and linking components connected to the chassis side-members or to whatever replaces them.

2.4.a. For vehicles fitted with a platform lift the fitting of the rear protective structure may be interrupted for the purposes of the mechanism. In such cases, the following shall apply:

2.4.a.1. the lateral distance between the fitting elements of the rear protective structure and the elements of the platform lift, which make the interruption necessary, may amount to no more than 2.5 cm;

2.4.a.2. the individual elements of the rear protective structure shall, in each case, have an effective surface area of at least 350 cm²;

2.4.a.3. the individual elements of the rear protective structure shall be of sufficient dimensions to comply with the requirements of paragraph 2.4.5.1, whereby the relative positions of the test points are determined. If the points P1 are located within the interruption area mentioned in 2.4a, the points P1 to be used shall be located in the middle of any lateral section of the rear protective structure;

2.4.a.4. for the area of interruption of the rear protective structure and for the purposes of the platform lift, point 2.4.1. need not apply.

It shall have the following characteristics:

2.4.1. the device shall be fitted as close to the rear of the vehicle as possible. When the vehicle is unladen⁴ the lower edge of the device shall at no point be more than 55 cm above the ground;

2.4.2. the width of the device shall at no point exceed the width of the rear axle measured at the outermost points of the wheels, excluding the bulging of the tyres close to the ground, nor shall it be more than 10 cm shorter on either side. Where there is more than one rear axle, the width to be considered is that of the widest;

2.4.3. the section height of the cross-member shall be not less than 10 cm. The lateral extremities of the cross-member shall not bend to the rear or have a sharp outer edge; this condition is fulfilled when the lateral extremities of the cross-member are rounded on the outside and have a radius of curvature of not less than 2.5 mm;

2.4.4. the device may be so designed that its position at the rear of the vehicle can be varied. In this event, there shall be a guaranteed method of securing it in the service position so that any unintentional change of position is precluded. It shall be possible for the operator to vary the position of the device by applying a force not exceeding 40 daN;

2.4.5. the device shall offer adequate resistance to forces applied parallel to the longitudinal axis of the vehicle, and be connected, when in the service position, with the chassis side-members or whatever replaces them.

⁴ As defined in item 2.6 of Appendix 1.

This requirement shall be deemed to be satisfied if it is shown that both during and after the application the horizontal distance between the rear of the device and the rear extremity of the vehicle does not exceed 40 cm at any of the points P1, P2 and P3. In measuring this distance, any part of the vehicle which is more than 3 m above the ground when the vehicle is unladen shall be excluded;

- 2.4.5.1. points P1 are located 30 cm from the longitudinal planes tangential to the outer edges of the wheels on the rear axle; points P2, which are located on the line joining points P1, are symmetrical to the median longitudinal plane of the vehicle at a distance from each other of 70 to 100 cm inclusive, the exact position being specified by the manufacturer. The height above the ground of points P1 and P2 shall be defined by the vehicle manufacturer within the lines that bound the device horizontally. The height shall not, however, exceed 60 cm when the vehicle is unladen. P3 is the centre-point of the straight line joining points P2;
- 2.4.5.2. a horizontal force corresponding to 25 % of the maximum technically permissible mass of the vehicle but not exceeding 5×10^4 N shall be applied successively to both points P1 and to point P3;
- 2.4.5.3. a horizontal force corresponding to 50 % of the maximum technically permissible mass of the vehicle but not exceeding 10×10^4 N shall be applied successively to both points P2;
- 2.4.5.4. the forces specified in 2.4.5.2 and 2.4.5.3 above shall be applied separately. The order in which the forces are applied may be specified by the manufacturer;
- 2.4.5.5. whenever a practical test is performed to verify compliance with the abovementioned requirements, the following conditions shall be fulfilled:
 - 2.4.5.5.1. the device shall be connected to the chassis side-members of the vehicle or to whatever replaces them;
 - 2.4.5.5.2. the specified forces shall be applied by rams which are suitably articulated (e.g. by means of universal joints) and shall be parallel to the median longitudinal plane of the vehicle via a surface not more than 25 cm in height (the exact height shall be indicated by the manufacturer) and 20 cm wide, with a radius of curvature of 5 ± 1 mm at the vertical edges; the centre of the surface is placed successively at points P1, P2 and P3.
- 2.5. By way of derogation from the abovementioned requirements, vehicles of the following categories need not comply with the requirements of this Annex as regards rear underrun protection:
 - «slung» trailers and other similar trailers for the transport of logs or other very long items,
 - vehicles for which rear underrun protection is incompatible with their use.

3. Exemptions

Vehicles where any rear protective structure is incompatible with their rear fitted operational devices, shall be exempted from the requirement. Otherwise, the vehicle shall be fitted with a rear protective structure at its rear part that does not obstruct the function of those operational devices.

ANNEX XXVII
Requirements on lateral protection

1. General prescriptions

- 1.1. Every vehicle of categories R3b and R4b shall be so constructed and /or equipped as to offer, when a complete entity, effective protection to unprotected road users (pedestrians, cyclists, motorcyclists) against the risk of falling under the sides of the vehicle and being caught under the wheels.

This Annex shall not apply to:

- trailers specially designed and constructed for the carriage of very long loads of indivisible length, such as timber,
- vehicles designed and constructed for special purposes where it is not possible, for practical reasons, to fit such lateral protection.

- 1.2. A vehicle satisfies the requirement set out in point 1.1 if its side parts provide protection conforming to the provisions of the points 1.3. – 5. and of Appendix 1.

- 1.3. Positioning of the vehicle for testing its compliance to lateral protection

When tested for compliance with the technical specifications set out in point 2, the position of the vehicle shall be as follows:

on a horizontal and flat surface,

the steered wheels shall be in a straight-ahead position,

the vehicle shall be unladen,

semi-trailers shall be positioned on their supports with the loading surface horizontal.

2. Lateral protection provided by a specific device (side guard)

- 2.1. The device shall not increase the overall width of the vehicle and the main part of its outer surface shall not be more than 120 mm inboard from the outermost plane (maximum width) of the vehicle. Its forward end may be turned inwards on some vehicles in accordance with points 2.4.2 and 2.4.3. Its rearward end shall not be more than 30 mm inboard from the outermost edge of the rear tyres (excluding any bulging of the tyres close to the ground) over at least the rearmost 250 mm.

- 2.2. The outer surface of the device shall be smooth, substantially flat or horizontally corrugated and so far as possible continuous from front to rear; adjacent parts may however overlap, provided that the overlapping edge faces rearwards or downwards, or a gap of not more than 25 mm measured longitudinally may be left, provided that the rearward part does not protrude outboard of the forward part; domed heads of bolts or rivets may protrude beyond the surface to a distance not exceeding 10 mm and other parts may protrude to the same extent provided that they are smooth and similarly rounded; all external edges and corners shall be rounded with a radius not less than 2.5 mm (tested as prescribed in Appendix 1).

- 2.3. The device may consist of a continuous flat surface, or of one or more horizontal rails, or a combination of surface and rails; when rails are used, they shall be not more than 300 mm

apart and not less than:

50 mm high in the case of category R3b vehicles,

100 mm high and essentially flat in the case of R4b vehicles. Combinations of surfaces and rails shall form a continuous side guard subject, however, to the provisions of point 2.2.

- 2.4. The forward edge of the side guard shall be constructed as follows:
- 2.4.1. Its position shall be:
- 2.4.1.1. on a balanced trailer where the axles' distance is equal to or greater than 3m: not more than 500 mm to the rear of the transverse vertical plane tangential to the rearmost part of the tyre on the wheel immediately forward of the guard;
- 2.4.1.2. on a balanced trailer where the axles' distance is less than 3m and on any other trailer: not more than 250 mm to the rear of the transverse median plane of the support legs, if support legs are fitted, but in any case the distance of the front edge to the transverse plane passing through the centre of the coupling pin in its rearmost position may not exceed 2.7 m.
- 2.4.2. Where the forward edge lies in otherwise open space, the edge shall consist of a continuous vertical member extending over the whole height of the guard; the outer and forward faces of this member shall measure at least 50 mm rearward and be turned 100 mm inwards in the case of R3b and at least 100 mm rearwards and be turned 100 mm inwards in the case of R4b.
- 2.5. The rearward edge of the side guard shall not be more than 300 mm forward of the transverse vertical plane tangential to the foremost part of the tyre on the wheel immediately to the rear; a continuous vertical member is not required on the rear edge.
- 2.6. The lower edge of the side guard shall at no point be more than 550 mm above the ground.
- 2.7. The upper edge of the guard shall not be more than 350 mm below that part of the structure of the vehicle, cut or contacted by a vertical plane tangential to the outer surface of the tyres, excluding any bulging close to the ground, except in the following cases:
- 2.7.1. where the plane in point 2.7 does not cut the structure of the vehicle, the upper edge shall be level with the surface of the load-carrying platform, of 950 mm from the ground, whichever is the less;
- 2.7.2. where the plane in point 2.7 cuts the structure of the vehicle at a level more than 1.3 m above the ground, then the upper edge of the side guard shall not be less than 950 mm above the ground.
- 2.8. Side guards shall be essentially rigid, securely mounted (they shall not be liable to loosening due to vibration in normal use of the vehicle) and made of metal or any other suitable material.

The side guard shall be considered suitable if it is capable of withstanding a horizontal static force of 1 kN applied perpendicularly to any part of its external surface by the centre of a ram the face of which is circular and flat, with a diameter of $220 \text{ mm} \pm 10 \text{ mm}$, and if the deflection of the guard under load is then not more than:

30 mm over the rearmost 250 mm of the guard, and

150 mm over the remainder of the guard.

- 2.8.1. The above requirement may be checked by means of calculations.
- 2.9. The side guard may not be used for the attachment of brake, air or hydraulic pipes.
3. By derogation from the above provisions, vehicles of the following types need comply only as indicated in each case:
 - 3.1. An extendible trailer shall comply with all of the requirements of point 2, when closed to its minimum length; when the trailer is extended, the side guards shall comply with points 2.6, 2.7 and 2.8, and with either 2.4 or 2.5 but not necessarily both; extension of the trailer shall not produce gaps in the length of the side guards;
 - 3.2. a tank-vehicle that is a vehicle designed solely for the carriage of fluid substance in a closed tank permanently fitted to the vehicle and provided with hose or pipe connections for loading or unloading, shall be fitted with side guards which comply so far as is practicable with all the requirements of point 2; strict compliance may be waived only where operational requirements make this necessary;
 - 3.3. On a vehicle fitted with extendible legs to provide additional stability during loading, unloading or other operations for which the vehicle is designed, the side guard may be arranged with additional gaps where these are necessary to permit extension of the legs.
4. If the sides of the vehicle are so designed and/or equipped that by their shape and characteristics their component parts together meet the requirements of point 2, they may be regarded as replacing the side guards.
5. **Alternative requirements**

Alternatively to complying with points 1.3. to 2.9. and point 4., manufacturers may choose whether to comply with points 2 and 3 and Parts I, II and III as well as Annex 3 of UNECE Regulation No 73 as referenced in Annex I.

Appendix 1

Method for determining the height of external surface projections

1. The height H of a projection is determined graphically by reference to the circumference of a 165 mm diameter circle, internally tangential to the external outline of the external surface at the section to be checked.
2. H is the maximum value of the distance, measured along a straight line passing through the centre of the 165 mm diameter circle, between the circumference of the aforesaid circle and the external contour of the projection (see Figure 1).
3. In cases where it is not possible for a 100 mm diameter circle to contact externally part of the external outline of the external surface at the section under consideration, the surface outline in this area shall be assumed to be that formed by the circumference of the 100 mm diameter circle between its tangent points with the external outline (see Figure 2).
4. Drawings of the necessary sections through the external surface shall be provided by the manufacturer to allow the height of the projections referred to above to be measured.

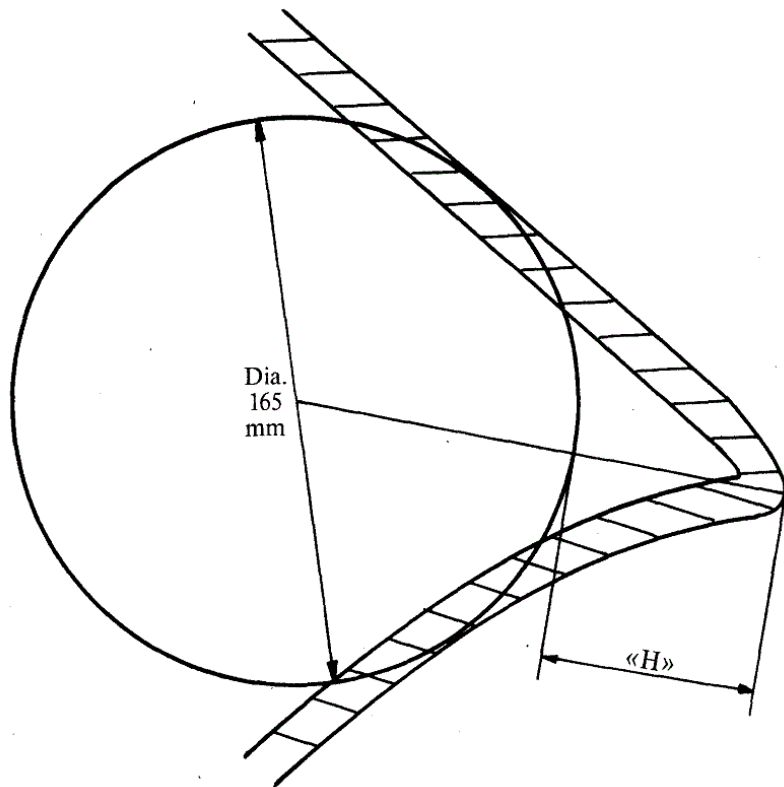

Figure 1

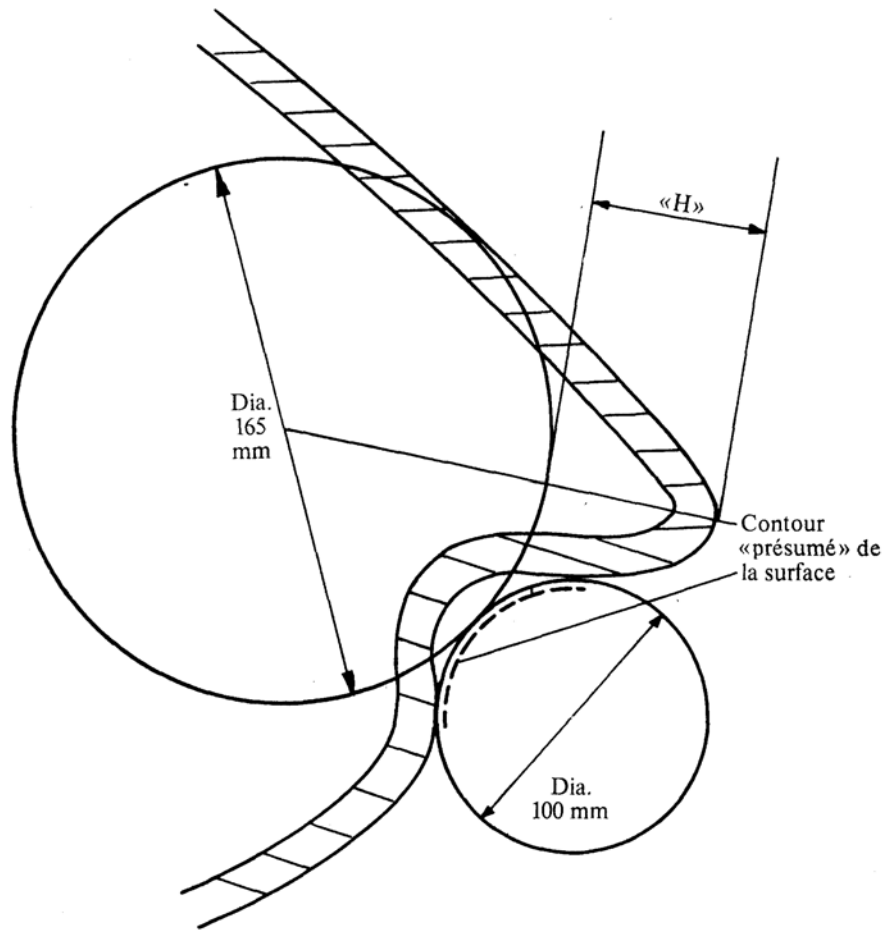

Figure 2

ANNEX XXVIII
Requirements on load platforms

1. The centre of gravity of the platform shall be situated between the axles.
2. The dimensions of the platform shall be such that:
 - the length does not exceed 1.4 times the front or rear track of the tractor, whichever is the larger,
 - the width does not exceed the maximum overall width of the tractor without equipment.
3. The platform shall be laid out symmetrically in relation to the longitudinal median plane of the tractor.
4. The height of the load platform above the ground shall be not more than 150 cm.
5. The type of platform and the way it is fitted shall be such that, with a normal load, the driver's field of vision remains adequate and the various compulsory lighting and light-signalling devices may continue to fulfill their proper function.
6. The load platform may be detachable; it shall be attached to the tractor in such a way as to avoid any risk of accidental detachment.
7. For tractors of category T4.3, the length of the platform shall not exceed 2.5 times the maximum front or rear track of the tractor, whichever is the larger.
8. For vehicles with multiple load platforms, the centre of gravity of the vehicle with loaded platform(s) and without driver shall be situated between the front-most and the rearmost axle in all loading conditions. Any load shall be evenly distributed on the load platform(s).

ANNEX XXIX
Requirements on towing devices

1. Number

Every tractor shall have a special device to which it shall be possible to attach a connection such as a tow-bar or a tow-rope for towing purposes.

2. Position

The device shall be fitted to the front of the tractor, which shall be equipped with a coupling pin or hook.

3. Design

The towing device shall be of the slotted-jaw type or a winch suitable for its application. The opening at the centre of the locking pin shall be $60 \text{ mm} + 0.5/- 1.5 \text{ mm}$ and the depth of the jaw measured from the centre of the pin shall be $62 \text{ mm} \pm 0.5 \text{ mm}$.

The coupling pin shall have a diameter of $30 + 1.5 \text{ mm}$ and be fitted with a device preventing it from leaving its seating during use. The securing device shall be non-detachable.

The tolerance of $+ 1.5 \text{ mm}$ referred to above should not be regarded as a manufacturing tolerance but as a permissible variation in nominal dimensions for pins of different designs.

4. Alternative requirements

4.1. The dimensions of point 3 can be exceeded if the manufacturer deems that they are not adequate for the size or mass of the vehicle.

4.2. Manufacturers may choose to apply on vehicles with a maximum technically permissible mass not exceeding 2,000kg either the requirements of points 1, 2 and 3 or the requirements of Commission (EU) Regulation No 1005/2010⁵.

5. Instructions

The correct use of the towing device shall be explained in the Operator's manual, in accordance with the requirements laid down on the basis of Article 18(2)(l), (n), (q) and (4) of Regulation (EU) No 167/2013.

⁵ Commission (EU) Regulation No 1005/2010 of 8 November 2010 concerning type-approval requirements for motor vehicle towing devices and implementing Regulation (EC) No 661/2009 of the European Parliament and of the Council concerning type-approval requirements for the general safety of motor vehicles, their trailers and systems, components and separate technical units intended therefor (OJ L 291, 9.11.2010, p. 36).

ANNEX XXX
Requirements on tyres

1. Definitions

For the purposes of this Annex:

- 1.1. 'Cyclic service' means the condition that applies when the load on the tyre cycles between the fully loaded and the unloaded condition;
- 1.2. 'High and sustained torque' means the condition that occurs due to a load on the drawbar or hitch;
- 1.3. 'Applicable tyre inflation pressure' means the internal pressure of the tyre, with the tyre at ambient temperature (i.e. cold tyre pressure), recommended in conformity to the load, speed and service conditions of the vehicle. It does not include any pressure built up due to tyre usage and is expressed in kPa;
- 1.4. 'Maximum load rating' means the mass which a tyre can carry when operated in conformity with requirements governing utilisation specified by the tyre manufacturer;
- 1.5. 'Maximum permissible mass per axle according to tyre specification' means the mass corresponding to the maximum permissible static vertical load that can be transmitted to the ground by the wheels of the axle as restricted by the maximum load rating of tyre types that can be fitted to the vehicle as listed in the information document.

2. Requirements

- 2.1. Requirements applying to the component type-approval of tyres
 - 2.1.1. Provisions for pneumatic tyres designed primarily for agricultural vehicles with diagonal or bias-ply and bias-belted construction with a reference speed not exceeding 40 km/h (i.e. speed symbol A8), as well as radial tyres designed primarily for construction application purposes (i.e. tyres marked "Industrial", "IND", "R-4" or "F-3").
 - 2.1.1.1. All tyres conforming to the relevant type shall be marked in conformity with points 2.1.1.2. to 2.1.1.2.4.
 - 2.1.1.2. Specific requirements for markings.
 - 2.1.1.2.1. Tyres shall bear the following markings, in conformity with ISO 4223-1:2002/Amd 1:2011, including:
 - the tyre size designation;
 - the load capacity index (i.e. a numerical code which indicates the load the tyre can carry at the speed corresponding to the associated speed category);
 - the speed category symbol (i.e. a symbol which indicates the maximum speed at which the tyre can carry the load corresponding to its load index); and
 - the word "TUBELESS" if the tyre is designed for use without an inner tube.
 - 2.1.1.2.2. Tyres shall bear the following additional markings:

- the manufacturer's trade name or mark;
- the inflation pressure that shall not be exceeded for the purpose of bead seating during tyre mounting;
- in case of implement tyres the service description (i.e. load index and speed category symbol) shall be supplemented with the indication whether it applies to "drive wheel" or to "free rolling wheel" or to both; and
- the date of manufacture in the form of a group of four digits, the first two showing the week and the last two the year of manufacture.

2.1.1.2.3. All markings mentioned in points 2.1.1.2.1. and 2.1.1.2.2. shall be legibly and permanently moulded into or onto the sidewall and produced as part of the process during manufacture. The use of branding or other methods of marking after completion of the original manufacturing process is not permitted.

2.1.1.2.4. In line with Article 34(2) of Regulation (EU) No 167/2013, no type-approval mark is required for pneumatic tyres designed primarily for agricultural vehicles with diagonal or bias-ply and bias-belted construction with a reference speed not exceeding 40 km/h (i.e. speed symbol A8), as well as radial tyres designed primarily for construction application purposes (i.e. tyres marked "Industrial", "IND", "R-4" or "F-3") approved in accordance with this Regulation.

The information document and information folder that shall be submitted with the application for type-approval of those tyres are specified in the models set out in Article 68(a) of Regulation (EU) No 167/2013.

A unique type-approval number, the model of which is set out in Article 68(h) of Regulation (EU) No 167/2013, shall be assigned to each type-approved tyre and a type-approval certificate, the model of which is set out in Article 68(c) of Regulation (EU) No 167/2013, shall be issued.

2.1.2. New pneumatic tyres conforming to the type complying with the requirements set out in points 2.1.1. to 2.1.1.2.4 may continue to be placed on the market until 31 December 2018.

2.1.2.1. Tyres that were manufactured prior to the date set out in point 2.1.2. which do not comply with the requirements of points 2.1.3. to 2.1.3.1. and which comply with the requirements set out in points 2.1.1. to 2.1.1.2.4. may be sold for a period not exceeding 30 months from that date.

2.1.3. Requirements for pneumatic tyres designed primarily for agricultural vehicles other than those set out in points 2.1.1. to 2.1.1.2.4.

2.1.3.1. Tyres not covered by the provisions of points 2.1.1 to 2.1.1.2.4. shall conform to the types approved under the relevant UNECE regulations.

2.2. Requirements for the approval of a type of vehicle with regard to the installation of tyres

2.2.1. Specific requirements for the installation of tyres on vehicles with a maximum design speed not exceeding 65 km/h.

2.2.1.1. Subject to the provisions of point 2.2.1.2. all tyres fitted to vehicles, including any spare tyre, shall be type-approved according to UNECE Regulation No 106 as referenced in Annex I.

- 2.2.1.1.1. For the purpose of vehicle type-approval in accordance with Regulation (EU) No 167/2013, tyres designed primarily for agricultural vehicles with diagonal or bias-ply and bias-belted construction with a reference speed not exceeding 40 km/h (i.e. speed symbol A8), as well as radial tyres designed primarily for construction application purposes (i.e. tyres marked "Industrial", "IND", "R-4" or "F-3"), may until 31 December 2017 be type-approved according to this Regulation instead.
- 2.2.1.2. Where a vehicle is designed for conditions of use which are incompatible with the characteristics of tyres type-approved according to UNECE Regulation No 106, as referenced in Annex I, or this Regulation and it is therefore necessary to fit tyres with different characteristics, the requirements of point 2.2.1.1. do not apply, provided that the following conditions are met:
- the tyres are in accordance with Regulation (EC) No 661/2009 of the European Parliament and of the Council⁶ (i.e. type-approved according to UNECE regulations Nos 30, 54 and 117 as referenced in Annex I to this Regulation) or type-approved according to UNECE Regulation No 75, as referenced in Annex I, and
 - the approval authority and technical service are satisfied that the tyres fitted are suitable for the operating conditions of the vehicle. The nature of the exemption and reasons for acceptance shall be clearly stated in the test report.
- 2.2.2. Specific requirements for the installation of tyres on vehicles with a maximum design speed exceeding 65 km/h.
- 2.2.2.1. Subject to the provisions of point 2.2.2.2., all tyres fitted to vehicles, including any spare tyre, shall be in accordance with Regulation (EC) No 661/2009 (i.e. type-approved according to UNECE Regulations Nos 30, 54 and 117 as referenced in Annex I).
- 2.2.2.2. Where a vehicle is designed for conditions of use which are incompatible with the characteristics of tyres type-approved in accordance with Regulation (EC) No 661/2009 and it is therefore necessary to fit tyres with different characteristics, the requirements of point 2.2.2.1. do not apply, provided that the following conditions are met:
- the tyres are type-approved according to UNECE Regulation No 75; as referenced in Annex I, and
 - the approval authority and technical service are satisfied that the tyres fitted are suitable for the operating conditions of the vehicle. The nature of the exemption and reasons for acceptance shall be clearly stated in the test report.
- 2.2.3. General requirements for the installation of tyres
- 2.2.3.1. All tyres normally fitted to one axle shall be of the same type, with the exception of the cases mentioned in points 2.2.4.1.1 and 2.2.4.1.2.
- 2.2.3.2. The space in which the wheel revolves shall be such as to allow unrestricted movement when using the maximum permissible size of tyres and rim widths, taking into account the

⁶ Regulation (EC) No 661/2009 of the European Parliament and of the Council of 13 July 2009 concerning type-approval requirements for the general safety of motor vehicles, their trailers and systems, components and separate technical units intended therefor (OJ L 200, 31.7.2009, p. 1).

minimum and maximum wheel off-sets if applicable, within the minimum and maximum suspension and steering constraints as declared by the vehicle manufacturer. This shall be verified by performing the checks with the largest and the widest tyres in each space, taking into account the applicable rim size and the maximum allowed section width and outer diameter of the tyre, in relation to the tyre size designation as specified in the relevant UNECE regulation. The checks shall be performed by rotating a representation of the tyre's maximum envelope, not just the actual tyre, in the space for the wheel in question.

2.2.3.3. The technical service may agree to an alternative test procedure (e.g. virtual testing) to verify that the requirements of point 2.2.3.2 are met, provided that the clearance between the tyre's maximum envelope and vehicle structure is complied with.

2.2.4. Load capacity

2.2.4.1. The maximum load rating of each tyre fitted on the vehicle, taking into due account the maximum design speed of the vehicle and the most demanding service conditions, as well as the special cases of points 2.2.6. to 2.2.6.5. if applicable, shall be at least equal to the following:

- the maximum permissible mass per axle where the axle is equipped with one tyre only;
- half of the maximum permissible mass per axle where the axle is equipped with two tyres in single formation;
- 0.285 times the maximum permissible mass per axle where the axle is equipped with two sets of tyres in dual (twin) formation;
- 0.20 times the maximum permissible mass per axle where the axle is equipped with two sets of tyres in triple formation.

2.2.4.1.1. In case where dual or triple formations are composed by tyres of different types (i.e. tyre size designations and service descriptions) the following apply:

the tyres shall have the same overall diameter;

the tyres shall be of the same “category of use”, “structure” and “speed category symbol” as defined in paragraphs 2.1.3, 2.1.4 and 2.1.5 of UNECE regulation 106, as referenced in Annex I;

the vehicle shall be equipped symmetrically;

the sum of the maximum load ratings of all tyres fitted to the axle shall be at least 1.14 times the maximum permissible axle mass in the case of dual formation and 1.2 times the maximum permissible axle mass in the case of triple formation;

the share of the maximum permissible mass per axle on each tyre of the formation shall not exceed the maximum load rating of each tyre;

the inflation pressure of each tyre in the formation shall conform to the recommendation of the tyre manufacturer taking into account the actual load on each tyre and the service conditions.

2.2.4.1.2. When a vehicle may be fitted on each axle with tyres for which the sum of maximum load rating is less than the maximum permissible mass per axle, the requirements of points

2.2.4.1 and 2.2.4.1.1 apply with the maximum permissible mass per axle according to the tyre specification instead of the maximum permissible mass per axle.

The maximum permissible mass per axle according to the tyre specification and the maximum permissible mass per axle are the ones declared by the vehicle manufacturer.

The owner's manual, the information document and the certificate of conformity shall mention the values of mass per axle for each one of them depending on the maximum permissible mass per axle according to the tyre specification.

2.2.4.2. The maximum load rating of a tyre is determined as follows:

2.2.4.2.1. In the case of tyres identified by speed symbol D (i.e. 65 km/h) or lower the 'table load-capacity variation with speed' as referred to in paragraph 2.30 of UNECE Regulation No 106, as referenced in Annex I, for its specific category of use is taken into account. The table shows, as a function of the load-capacity indices and nominal-speed-category symbols, the load variations which a pneumatic tyre can withstand taking into account the maximum design speed of the vehicle.

2.2.4.2.2. In the case of tyres identified by speed symbol F (80 km/h) or higher, type-approved according to UNECE Regulation No 54, the 'table load-capacity variation with speed' as referred to in paragraph 2.29 of that Regulation is taken into account. The table shows, as a function of the load-capacity indices and nominal-speed-category symbols, the load variations which a pneumatic tyre can withstand taking into account the maximum design speed of the vehicle.

2.2.4.2.3. In the case of tyres type-approved according to UNECE Regulation No 75, the 'table load-capacity variation with speed' as referred to in paragraph 2.27 of that Regulation is taken into account. The table shows, as a function of the load-capacity indices and nominal-speed-category symbols, the load variations which a pneumatic tyre can withstand taking into account the maximum design speed of the vehicle.

2.2.4.3. The applicable tyre inflation pressures shall be stated on the vehicle (e.g. on one or more labels). The information shall be clearly legible without the need to remove any parts with the use of tools and shall be affixed in a way that it is not easily removed. The relevant information concerning load and speed indices as well as the applicable tyre inflation pressures shall be stated clearly in the instruction manual of the vehicle in order to ensure that suitable replacement tyres with an appropriate load capacity shall be fitted when necessary, once the vehicle has been put into service.

2.2.4.3.1. The load capacity index indicated in the information document shall be the lowest grade which is compatible with the maximum permissible load on the tyre in question. Tyres with a higher grade may be fitted.

2.2.5. Speed capacity

2.2.5.1. Every tyre fitted normally on the vehicle shall bear a speed category symbol.

2.2.5.1.1. The speed category symbol shall be compatible with the maximum design speed.

2.2.5.1.2. The adjusted load rating as referred to in points 2.2.4.2.1. to 2.2.4.2.3. shall be taken into account.

2.2.5.2. The relevant information and the applicable tyre inflation pressure shall be stated clearly in the vehicle owner's handbook in order to ensure that suitable replacement tyres with an appropriate speed capacity shall be fitted when necessary, once the vehicle has been put

into service.

- 2.2.5.2.1. The speed category as indicated in the information document shall be the lowest grade which is compatible with the maximum design vehicle speed. Tyres with a higher grade may be fitted.
- 2.2.6. Specific requirements for vehicles fitted with tyres identified by speed symbols corresponding to a maximum design speed not exceeding 65 km/h (i.e. up to symbol D).
 - 2.2.6.1. Cyclic service
 - 2.2.6.1.1. In cyclic service:
 - 2.2.6.1.1.1. unloading shall occur before road transport;
 - 2.2.6.1.1.2. vehicles equipped with injectors, or any other ground engaging attachment (e.g. ploughs) or dragging objects are considered to be operating in a high torque mode;
 - 2.2.6.1.1.3. vehicles towing trailers are also considered to be operating in a high torque mode when operating on slopes greater than 11° (20 %).
 - 2.2.6.1.2. In case tyres classified in category of use 'Tractor - Steering wheel' and marked 'FRONT', 'F-1', 'F-2' or 'F-3' operated at speeds up to a maximum speed of 10 km/h on a tractor equipped with a 'Front end loader' the maximum load on a tyre shall not exceed 2.0 times the load corresponding to the load index marked on the tyre.
 - 2.2.6.1.3. In case tyres classified in category of use 'Tractor - Drive wheel' operating in field applications with 'high and sustained torque' (e.g. ploughing) the maximum load on a tyre shall not exceed the load corresponding to the load index marked on the tyre multiplied by 1.07 for tyres with speed symbol A8 or 1.15 for tyres with speed symbol D.
 - 2.2.6.1.4. In case tyres classified in category of use 'Tractor - Drive wheel' operating in field applications without 'high and sustained torque' and up to a maximum speed of 10 km/h (excluding hillside operations over 20% slope) the maximum load on a tyre shall not exceed the load corresponding to the load index marked on the tyre multiplied by 1.70.
 - 2.2.6.1.5. In case tyres classified in category of use 'Tractor - Drive wheel' operating in field applications without 'high and sustained torque' and a maximum speed not exceeding 15 km/h (excluding hillside operations over 20% slope) the maximum load on a tyre shall not exceed the load corresponding to the load index marked on the tyre multiplied by 1.55.
 - 2.2.6.1.6. In case tyres classified in category of use 'Implement, installed on T-, R- and S-category vehicles, identified by speed symbols A6 or A8 with a nominal rim diameter code lower than 24, operating in 'cyclic high load variation' (i.e. when one way the vehicle is empty and on the other way the technically permissible maximum laden mass of the vehicle exceeds two times the unladen mass in running order) the variation in load capacity with speed identified in point 2.2.4.2.1. may be increased by up to 20% for Free Rolling wheels or by up to 43% in case of Drive wheels.
 - 2.2.6.1.7. The minimum tyre inflation pressure to be adopted for the cases of the points 2.2.6.1.2 to 2.2.6.1.6 shall be provided by the tyre manufacturer.
 - 2.2.6.2. In case of "Improved Flexion Tyre" or "Very High Flexion Tyre" classified in category of use 'Tractor – Drive wheel' (marked with prefix IF or VF) operated at speeds up to a maximum speed of 10 km/h fitted to a vehicle equipped with a 'Front end loader', the maximum load on a tyre shall not exceed 1.40 times the load corresponding to the load

index marked on the tyre and the relevant reference pressure shall be increased by 40 kPa.

- 2.2.6.2.1. In the case of "Improved Flexion Tyre" classified in category of use 'Tractor Drive Wheel', marked with prefix IF and with suffix 'CFO', fitted to T-category vehicles operating in field applications without 'high and sustained torque' (excluding hillside operations over 20% slope) the maximum load on a tyre shall not exceed the load corresponding to the load index marked on the tyre multiplied by 1.55 for operations up to a maximum speed of 15 km/h and by 1.30 for operations up to a maximum speed of 30 km/h.
- 2.2.6.3. In case of tyres classified in category of use 'Tractor – Drive wheel' marked with speed symbols A6 or A8 fitted to agricultural trailers operating at speeds between 25 km/h and 40 km/h, the maximum load on a tyre shall not exceed 1.20 times the load corresponding to the load index marked on the tyre.
- 2.2.6.4. In case of tyres classified in category of use 'Forestry machines' fitted to traction wheels of T-category vehicles, for forestry purposes, with high and sustained torque applications in forestry service at speeds up to 10 km/h (including the cases of points 2.2.6.1.1.2 and 2.2.6.1.1.3), the maximum load on a tyre shall not exceed the load corresponding to the load index marked on the tyre.
- 2.2.6.5. In case of tyres classified in category of use 'Implement', marked with speed symbols A6 or A8, fitted to free rolling steering wheels of T--category vehicles, the load capacity identified as 'Free Rolling', taking into account the maximum design speed of the vehicle as well as the variation of load capacity with speed according to definition 2.30 of UNECE Regulation No 106 shall be multiplied by up 0.80.
- 2.2.6.6. The relevant information and the applicable tyre inflation pressure shall be stated clearly in the instruction manual of the vehicle in order to ensure that suitable replacement tyres with an appropriate load capacity shall be fitted when necessary, once the vehicle has been put into service.
- 2.2.6.7. In case the applicable tyre inflation pressure for tyres fitted to agricultural or forestry vehicles exceeds 500 kPa, the tyre ground pressure exerted on a flat surface shall not exceed 0.8 MPa.
- 2.2.6.7.1. The tyre ground pressure is the average load transmitted by the correctly inflated tyre, through its contact area, onto a flat surface. The vertical force is taken under static conditions on the axis of the wheel taking into account the maximum permissible mass per axle as declared by the manufacturer. The tyre contact area consists of the flat surface contained within the convex polygonal curve circumscribing the smallest area containing all points of contact between the tyre and the ground.

3. Accredited in-house technical services of the manufacturer

A tyre manufacturer may be designated as accredited in-house technical service to perform self testing, in accordance with Article 60 of Regulation (EU) No 167/2013.

ANNEX XXXI
Requirements on spray-suppression systems

1. Requirements for all vehicles in category Tb and Rb

- 1.1. Tb category tractors shall be equipped with wheel guards (parts of the bodywork, mudguards, etc.).
- 1.2. The wheel guards shall be designed so that they protect other road users as far as possible from dispersed stones, dirt, ice, snow and water.
- 1.3. The wheels shall have a guard at the top, which covers at least $\frac{2}{3}$ of the total width of the tyre. The front and rear edge of the guard shall cover an angle of at least 90 degrees.
- 1.4. Rb category vehicles, equipped with C3 tyres or with other tyres with road profile permitted for those vehicles, shall be equipped with wheel guards that cover the total width of the tyre; the front part of the wheel guard shall cover an angle of at least 30° towards the front, the rear part of it shall cover an angle of at least 60° rearward of the vertical plane passing through of the centre of the wheels. Parts of the bodywork may form parts of the guards if they provide the same level of protection against thrown-up stones, mud, ice, snow and water.

ANNEX XXXII
Requirements on the reverse gear

All tractors shall be equipped with a device for reversing which can be operated from the driving position.

ANNEX XXXIII
Requirements on tracks

1. Definitions

For the purposes of this Annex:

- 1.1. 'Crawler undercarriage' means a system comprising at least two track rollers, which are spaced a specified distance apart in one plane (in-line) and a continuous metallic or rubber track belt runs around them.
- 1.2. 'Track rollers' means the system that transmits the weight of the vehicle and crawler undercarriage to the ground via the track belt, transmit torque from the vehicle's drive system to the track belt and may produce a change of direction of the moving belt.
- 1.3. 'Track belt' means a continuous flexible belt, which can absorb longitudinal tractive forces.
- 1.4. 'Track length' means the distance between the centres of the extreme track rollers under which the pads or track belt are contacting the ground.
- 1.5. 'Track width' means the distance between two parallel planes bounding the outside of the raised tread pattern (lugs) or pads.

2. Scope

- 2.1. Vehicles of category C shall fulfil the requirements of this Annex.
 - 2.1.1. Vehicles with maximum design speed not exceeding 15 km/h shall be equipped either with metallic tracks which are fitted with rubber pads on the track shoes or with tracks made of rubber only.
 - 2.1.2. Vehicles with a maximum design speed exceeding 15 km/h and not exceeding 40 km/h shall be equipped with tracks made of rubber only.
 - 2.1.3. Vehicles with a maximum design speed exceeding 40 km/h shall be equipped with tracks made of rubber only.

3. Requirements

- 3.1. Vehicles with a maximum design speed of not less than 15 km/h shall be equipped with rubber tracks.
- 3.2. Crawler undercarriages shall be non-damaging to roads. Vehicles with crawler undercarriages are non-damaging to roads if
 - 3.2.1. the limits set out in points 3.3 – 3.5 are not exceeded; and
 - 3.2.2. the contact surface of the crawler undercarriage with the road pavement is composed of an elastomeric material (such as rubber, etc.).
- 3.3. Mean Ground Contact Pressure
 - 3.3.1. Metallic tracks
 - 3.3.1.1. Vehicles falling under point 2.1.1 shall have a Mean Ground Contact Pressure, P, not

exceeding 0.65 MPa, calculated according to the following formula:

$$P \text{ (in MPa)} = \frac{\text{Maximum permissible mass of vehicle (in kg)} \times 9.81}{N_R \times A_P}$$

Where N_R is the total number of track rollers directly transferring load onto the road surface (via the tracks and pads) and A_P is the outer surface area of each pad (i.e. in contact with the road), in mm^2 . A_P is defined by measuring the footprint of one pad perpendicular under the centre of a not extreme track roller, by lowering a laden vehicle onto a suitable piece of cardboard or other permanently deformable material and measuring the area of the depression so caused.

3.3.1.2. For vehicles with a combination of wheeled axles and tracks, the load acting through the wheeled axles with the vehicle in the laden condition shall be measured using suitable weigh pads and subtracted from the overall maximum permissible mass to calculate P. Alternatively, the manufacturer's declared maximum combined load for the track trains may be substituted for the maximum permissible vehicle mass.

3.3.2. Rubber tracks

3.3.2.1. Vehicles falling under point 2.1.2 shall have a Mean Ground Contact pressure, P, not exceeding 0.5 MPa, calculated according to the following formula:

$$P \text{ (in MPa)} = \frac{\text{Maximum permissible mass of vehicle (in kg)} \times 9.81}{A_L}$$

Where A_L is the total surface area of rubber lugs in contact with the road, between the centres of the extreme track rollers under which the track belt is contacting the ground. The supplier of the rubber belt shall provide the percentage of lug area⁷ versus the total surface of the belt (defined as the track length multiplied by the track width), or the total lug area in contact with the road can be measured by lowering a laden vehicle onto a suitable piece of cardboard or other permanently deformable material and measuring the total area of the depressions so caused.

3.3.2.2. For vehicles with a combination of wheeled axles and tracks, the load acting through the wheeled axles with the vehicle in the laden condition shall be measured using suitable weigh pads and subtracted from the overall maximum permissible mass to calculate P. Alternatively, the manufacturer's declared maximum combined axle load for the track trains may be substituted for the maximum permissible vehicle mass.

3.3.2.3. Vehicles falling under point 2.1.3 shall have a Mean Ground Contact pressure, P, not exceeding 0.2 MPa, calculated according to points 3.3.2.1. and 3.3.2.2.

3.4. The maximum load per track roller shall not exceed 2,250 kg, calculated by dividing the maximum permissible mass in kg (allowing for any mass acting on any wheeled axles in the same way as 3.3.1.2 or 3.3.2.2) by the total number of track rollers directly transferring load onto the road surface.

3.5. The maximum load per unit length of track surface in contact with the road shall be calculated by dividing the maximum permissible mass in kg (allowing for any mass acting on any wheeled axles in the same way as 3.3.1.2 or 3.3.2.2) by the total length in metres of tracks in contact with the road at any given moment in time (i.e. between the centres of the extreme track rollers), on the basis of the limits provided under 3.3.1.1 or 3.3.2.1 or 3.3.2.3,

⁷ % of lug area, also known as 'land and sea'

following the vehicle case under 2.1.1 or 2.1.2 or 2.1.3 respectively, and 3.4.

- 3.6. On the inside of track belts, there shall be elements to ensure that the track belt shall be guided over the rollers. On the outside, there shall be a track pattern appropriate for the specific intended use in the agricultural or forestry sector.
- 3.7. Torque can be transmitted by friction (directly) or by positive engagement of track rollers with track.
- 3.8. In vehicles in which track belts are driven by friction, the operator shall have a continuous indication of track tension during road travel, or there shall be a visual and/or audible signal that is activated when the minimum belt tension is reached.
- 3.9. Steering action
 - 3.9.1. Vehicles falling under point 2.1.1 or under point 2.1.2
 - 3.9.1.1. For vehicles with only one track train at each side, the steering function shall be performed by changing the speed between the left-hand side and right-hand side track trains.
 - 3.9.1.2. For vehicles with two track trains at each side, the steering function shall be performed by articulation of the front and rear part of the vehicle around a central vertical axis or by pivoting of two opposite or all four track trains.
 - 3.9.2. Vehicles falling under point 2.1.3
 - 3.9.2.1. The steering function shall be performed by articulation of the front and rear part of the vehicle around a central vertical axis or by articulation of all track trains.
 - 3.9.3. Vehicles falling under point 2.1.1 or 2.1.2 or 2.1.3 and which the undercarriage is a combination of a wheeled axle and a set of the corresponding tracks
 - 3.9.3.1. The steering function shall be performed by changing the direction of the wheels on the wheeled axle and/or by articulation of the front and rear part of the vehicle around a central vertical axis. The wheeled axle can be installed at the front or at the rear of the vehicle.
- 3.10. Marking

The type-approval mark shall be affixed to the statutory plate in accordance with Annex XX, presenting the compliance of the vehicle with the appropriate requirements of points 3.1 – 3.7.

ANNEX XXXIV
Requirements on mechanical couplings

1. Definitions

For the purposes of this Annex:

- 1.1. 'Mechanical coupling between tractor and towed vehicle' means the components installed on the tractor and on the towed vehicle in order to provide the mechanical coupling between those vehicles.
- 1.2. 'Type of mechanical coupling between tractor and towed vehicle' means parts which do not differ from one another in such essential respects as:
 - nature of mechanical coupling component,
 - drawbar rings,
 - external shape, dimensions or mode of operation (e.g. automatic or non-automatic),
 - material,
 - value of D as defined in Appendix 2 for the test performed using the dynamic method or the trailer mass as defined in Appendix 3 for tests performed using the static method, and also the vertical load on the coupling point S.
- 1.3. 'Reference centre of mechanical coupling' means the point on the pin axis which is equidistant from the wings in the case of a fork and the point resulting from the intersection of the plane of symmetry of the hook with the generatrix of the concave part of the hook at the level of contact with the ring when this is in the traction position.
- 1.4. 'Height above ground of mechanical coupling' means the distance between the horizontal plane through the reference centre of the mechanical coupling and the horizontal plane on which the wheels of the tractor are resting.
- 1.5. 'Vertical load on the coupling point' means the load transmitted, under static conditions on the reference centre of the mechanical coupling.
- 1.6. 'Automatic mechanical coupling' means a mechanical coupling component which closes and secures itself when the sliding mechanism for the drawbar rings is actuated, without further action.
- 1.7. 'Weight on the front axle of the unladen tractor' means that part of the weight of the tractor which, under static conditions, is transmitted on the ground by the front axle of the tractor.

2. General requirements

- 2.1. The mechanical coupling components may be designed to function automatically or non-automatically.
- 2.2. The mechanical coupling components on the tractor shall conform to the dimensional and strength requirements in point 3.1 and point 3.2 and the requirements for the vertical load on the coupling point in point 3.3.
- 2.3. The mechanical coupling components shall be so designed and made that in normal use

they will continue to function satisfactorily and retain the characteristics prescribed by this Annex.

2.4. All parts of mechanical coupling components shall be made of materials of a quality sufficient to withstand the tests referred to in point 3.2. and shall have durable strength characteristics.

2.5. All the couplings and their locks shall be easy to engage and release and shall be so designed that under normal operating conditions no accidental de-coupling is possible.

In automatic coupling components the locked position shall be secured in a form-locking manner by two independently functioning safety devices. However, the latter may be released using the same control device.

2.6. The drawbar ring shall be capable of tilting horizontally at least 60° on both sides of the longitudinal axis of a non-built-in coupling device. In addition, vertical mobility of 20° upwards and downwards is required at all times. (See also Appendix 1.)

The angles of articulation shall not be attained at the same time.

2.7. The jaw shall permit the drawbar rings to swivel axially at least 90° to the right or left around the longitudinal axis of the coupling with a fixed braking momentum of between 30 and 150 Nm.

The towing hook, no-swivel clevis coupling, ball type coupling and pin type coupling shall allow the drawbar ring to swivel axially at least 20° to the right or left around the longitudinal axis of the coupling.

2.8. In order to prevent unintentional uncoupling from the hitch ring, the distance between the towing hook or ball head or pin (piton) tip and the keeper (clamping device) shall not exceed 10 mm at the maximum design load.

3. Special requirements

3.1. Dimensions

The dimensions of the mechanical coupling components on the tractor shall comply with Appendix 1, Figures 1 to 5 and Table 1.

The dimensions of the mechanical coupling components on the towed vehicle shall comply with the ones permitted by the combinations in Table 2 of Appendix 1.

3.2. Strength

3.2.1. For the purposes of checking their strength, the mechanical coupling components shall undergo:

(i) a dynamic test under the conditions set out in Appendix 2 or a static test under the conditions set out in Appendix 3, if they are used on vehicles with maximum design speed not exceeding 40 km/h;

(ii) a dynamic test under the conditions set out in Appendix 2, if they are used on vehicles with maximum design speed exceeding 40 km/h.

Alternatively, in both cases set out in points (i) and (ii), the dynamic test may be performed according to the requirements of the UNECE Regulation No 55 as referenced in Annex I.

- 3.2.2. The test shall not cause any permanent deformation, breaks or tears.
- 3.3. Vertical load on the coupling point (S)
- 3.3.1. The maximum static vertical load is laid down by the manufacturer. However, it shall not exceed 3,000 kg, except for the ball type coupling, where the maximum value shall not exceed 4,000 kg.
- 3.3.2. Conditions of acceptance:
- 3.3.2.1. The permissible static vertical load shall not exceed the technically permissible static vertical load recommended by the manufacturer of the tractor nor the static vertical load laid down for the mechanical coupling pursuant to component type-approval.
- 3.3.2.2. Whatever the state of loading of the tractor, the mass transmitted to the road by the wheels on the forward (steering) axle shall not be less than 20 % of the unladen mass of that tractor, but the maximum load on the rear (other) axle shall not be exceeded.
- 3.4. Height above the ground of the coupling device (h)

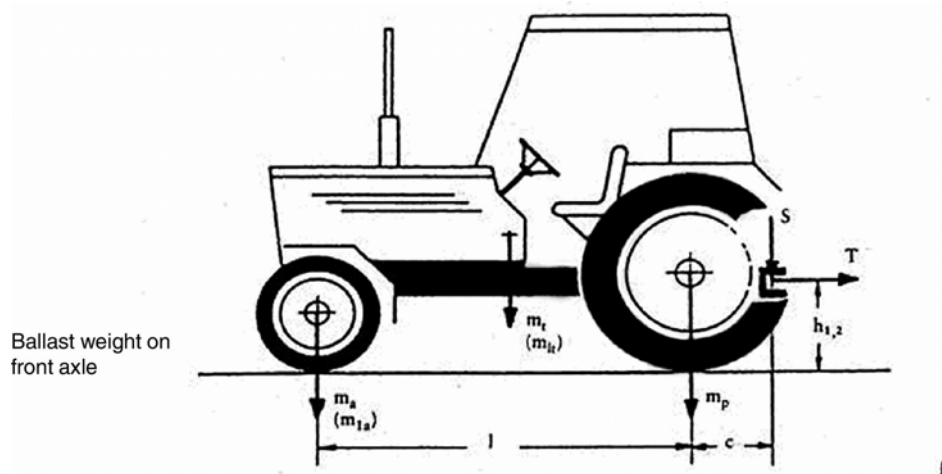

- 3.4.1. All tractors with a technically permissible maximum laden mass exceeding 2.5 tonnes shall be fitted with a trailer coupling having a ground clearance satisfying one of the following relations:

$$h_1 \leq (((m_a - 0.2 \cdot m_t) \cdot l - (S \cdot c)) / (0.6 \cdot (0.8 \cdot m_t + S))) \text{ or}$$

$$h_2 \leq (((m_{la} - 0.2 \cdot m_t) \cdot l - (S \cdot c)) / (0.6 \cdot (0.8 \cdot m_t - 0.2 \cdot m_t + S))) \text{ where:}$$

m_t	:	mass of the tractor,
m_{lt}	:	mass of the tractor with ballast weight on the front axle,
m_a	:	weight on the front axle of the unladen tractor,
m_{la}	:	weight on the front axle of the tractor with ballast weight on the front axle,
l	:	tractor wheelbase,

S	:	vertical load on the coupling point,
c	:	distance between the reference centre of the mechanical coupling and the vertical plane passing through the axle of the rear wheels of the tractor.

Masses m_t , m_{lt} , m_a and m_{la} are expressed in kg.

4. Conditions for granting EU type approval

4.1. A tractor representative of the tractor type to be approved, on which a coupling device, duly approved, is mounted is submitted to the technical services responsible for conducting the type-approval tests.

4.2. The technical service responsible for conducting the type-approval tests checks whether the approved type of coupling device is suitable for mounting on the type of tractor for which type-approval is requested. In particular, it ascertains that the attachment of the coupling device corresponds to that which was tested when the EU component type-approval was granted.

4.3. For each type of mechanical coupling component the application shall be accompanied by the following documents and particulars:

- scale drawings of the coupling device (three copies). These drawings shall in particular show the required dimensions in detail as well as the measurements for mounting the device,
- a short technical description of the coupling device specifying the type of construction and the material used,
- a statement of the value of D as referred to in Appendix 2 for the dynamic test or the value of T (towable mass in tonnes), corresponding to the technically permissible maximum laden trailer mass, as referred to in Appendix 3 for the static test, and also the vertical maximum load on the coupling point S (expressed in kg),
- one or more sample devices as required by the technical service.

4.4. The holder of the EU type-approval may apply for its extension for other types of coupling device.

4.5. The competent authorities grant such extension on the following conditions:

4.5.1. the new type of coupling device has received EU component type-approval;

4.5.2. it is suitable for mounting on the type of tractor for which the extension of the EU type-approval is requested;

4.5.3. the attachment of the coupling device on the tractor corresponds to that which was presented when EU component type-approval was granted.

4.6. A certificate, which template is set out in Article 68(c) of Regulation (EU) No 167/2013, is annexed to the EU type-approval certificate for each type-approval or type-approval extension which has been granted or refused.

4.7. If the application for EU type-approval for a type of tractor is made at the same time as the request for EU component type-approval for a type of coupling device on a tractor for

which EU type-approval is requested, then points 4.1 and 4.2 are unnecessary.

- 4.8. All mechanical couplings shall be accompanied by the manufacturer's instructions for use. These instructions shall include the EU component type-approved number and also the values of D (kN) or T (tonnes) depending on which test was performed on the coupling.

5. Markings

- 5.1. Every mechanical coupling component conforming to the type for which EU component type-approval has been granted shall bear a marking with the following inscriptions:
- 5.1.1. trade name or mark;
- 5.1.2. EU component type-approval mark conforming to the model set out in Article 68(h) of Regulation (EU) No 167/2013;
- 5.1.3. where the strength is checked in accordance with Appendix 2 (dynamic test):
permissible value of D (kN),
static vertical load value of S (kg);
- 5.1.4. where the strength is checked in accordance with Appendix 3 (static test):
towable mass T (tonnes), and vertical load on the coupling point S (kg).
- 5.1.5. The data shall be clearly visible, easily legible and durable.
6. Instead of complying with the requirements of this Annex, the manufacturer may choose to present a component type-approval for a mechanical coupling granted under UNECE Regulation No 55, as referenced in Annex I.
7. For vehicles which are fitted with handlebars, manufacturers may choose whether to apply either the requirements of points 2 to 6 or the requirements of the relevant provisions of Annex II(C)(4) to Regulation (EU) No 168/2013.

Appendix 1

Mechanical coupling types on tractors

'Clevis type mechanical coupling': see Figures 1 and 2.

'No-swivel clevis mechanical coupling': see Figure 1d.

'Towing hook': see Figure 1 – "Hitch-hook dimensions" in ISO 6489-1:2001.

'Tractor drawbar': see Figure 3.

'Ball type mechanical coupling': see Figure 4.

'Pin (piton) type mechanical coupling': see Figure 5.

Tractor drawbar dimensions shall comply with those of the following categories of ISO 6489-3:2004:

Category (0) (pin 18); compatible with ISO 5692-3, shape W (22 mm hole).

Category (1) (pin 30); compatible with ISO 5692-3, shape X (35 mm ring); ISO 5692-2:2002 (40 mm hole); ISO 8755:2001 (40 mm hole).

Category (2) (pin 30); compatible with ISO 5692-3, shape X (35 mm ring); ISO 5692-2:2002 (40 mm hole); ISO 8755:2001 (40 mm hole).

Category (3) (pin 38); compatible with ISO 5692-1:2004 (50 mm ring); ISO 5692-3:2011 shape Y (50 mm hole); ISO 20019:2001.

Category (4) (pin 50); compatible with ISO 5692-3:2011 shape Z (68 mm hole).

Mechanical coupling types on towed vehicles

‘Hitch rings’ according to ISO 5692-1:2004 (50 mm hole, 30 mm ring diameter).

‘Hitch rings’ according to ISO 20019:2001 (50 mm hole centre, 30 to 41 mm ring diameter).

‘Swivel hitch rings’ according to ISO 5692-3:2011.

‘Coupling rings’ according to ISO 5692-2:2002 (40 mm socket).

‘Drawbar eye’ according to ISO 8755:2001 (40 mm hole).

‘Drawbar eye’ according to ISO 1102:2001 (50 mm hole).

‘Coupling device’ according to ISO 24347:2005 (80 mm ball diameter).

Drawings of mechanical couplings components

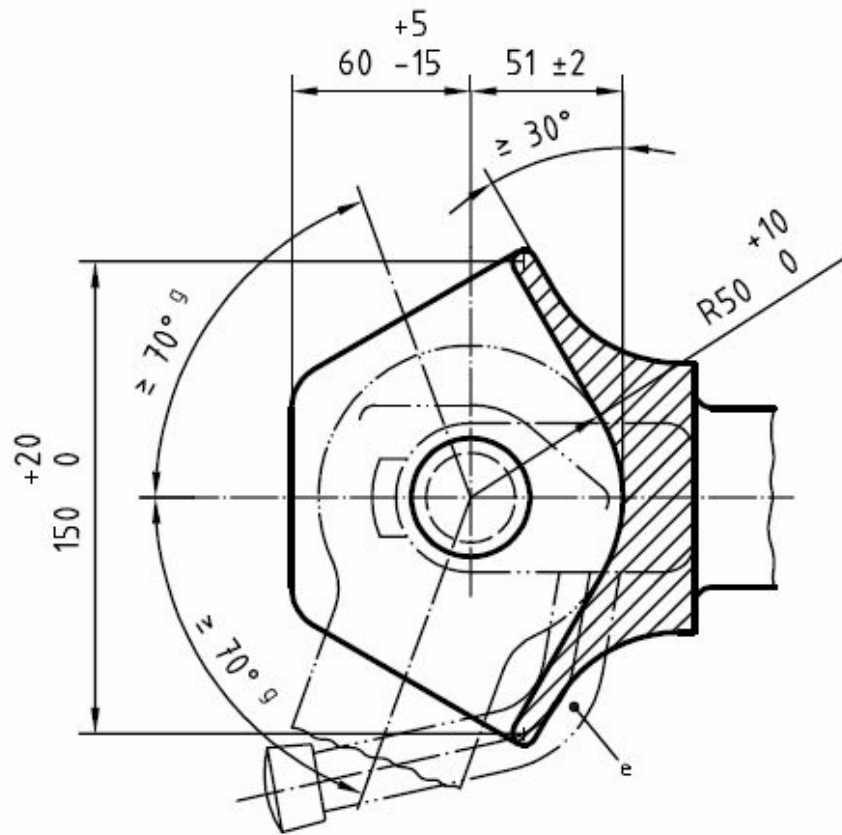
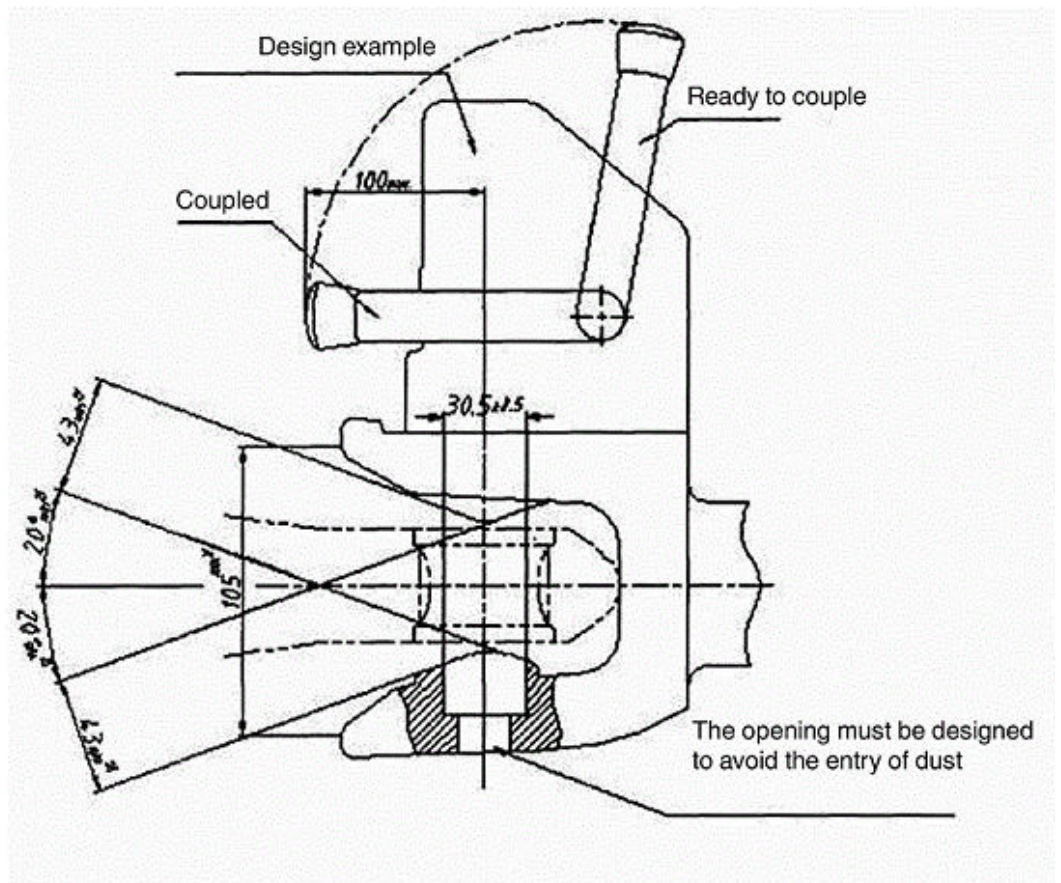

Figure 1b — Automatic trailer coupling, with cylindrical locking pin

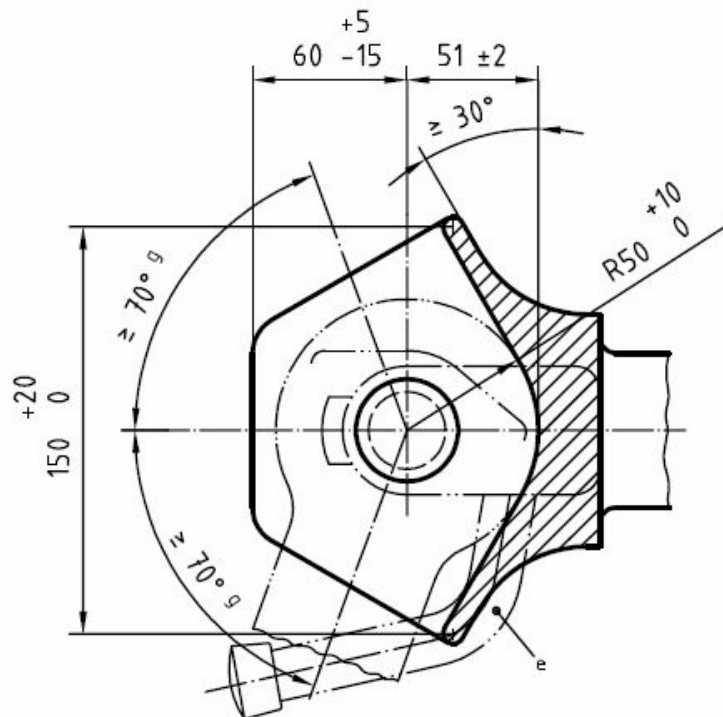
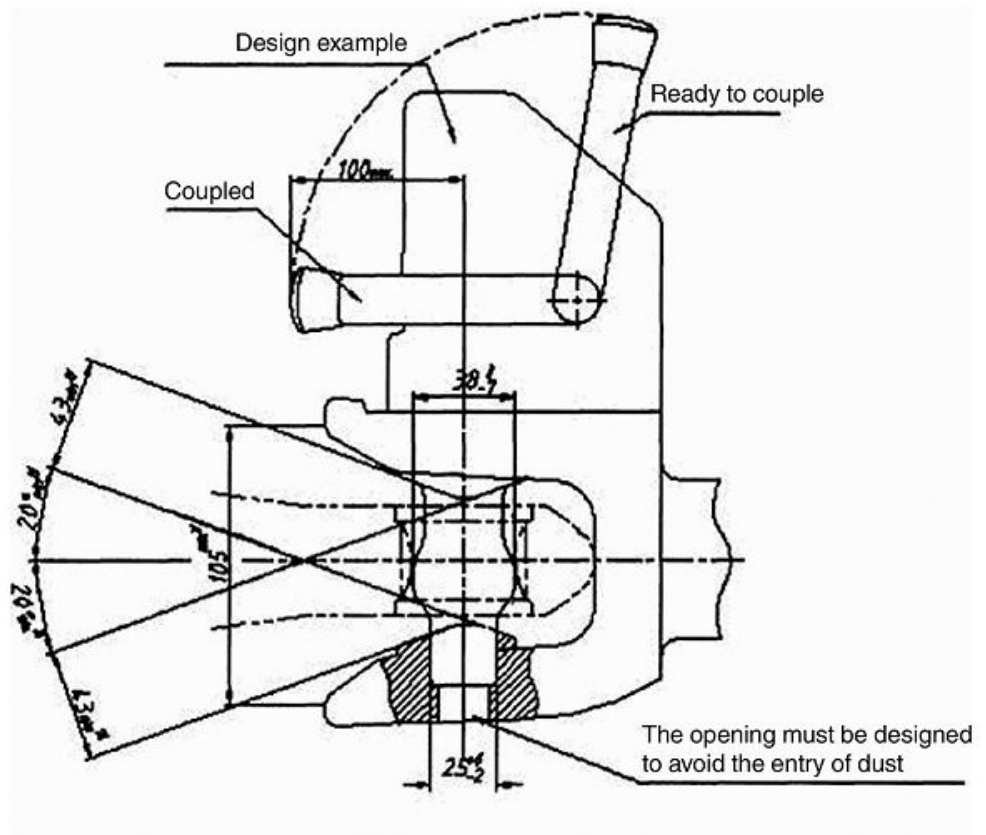

Figure 1c — Automatic trailer coupling, with cambered locking pin

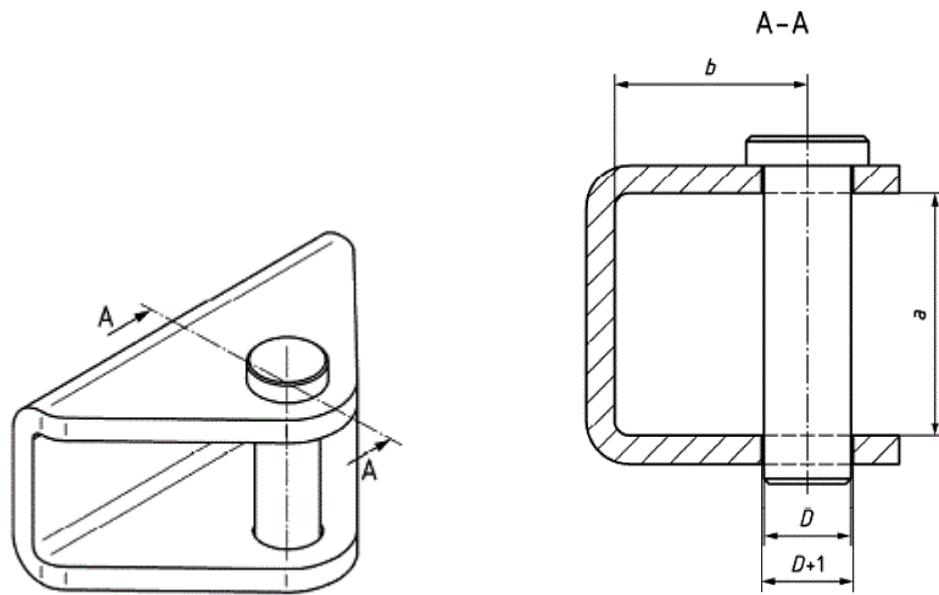

Table 1					
Shapes and dimensions of trailer or implement clevis couplings					
Vertical load S kg	D value D kN	Shape	Dimension mm		
			D $\pm 0,5$	a min.	b min.
$\leq 1,000$	≤ 35	w	18	50	40
$\leq 2,000$	≤ 90	x	28	70	55
$\leq 3,000$	≤ 120	y	43	100	80
$\leq 3,000$	≤ 120	z	50	110	95

Figure 1d – No-swivel clevis coupling (corresponding to ISO 6489-5:2011)

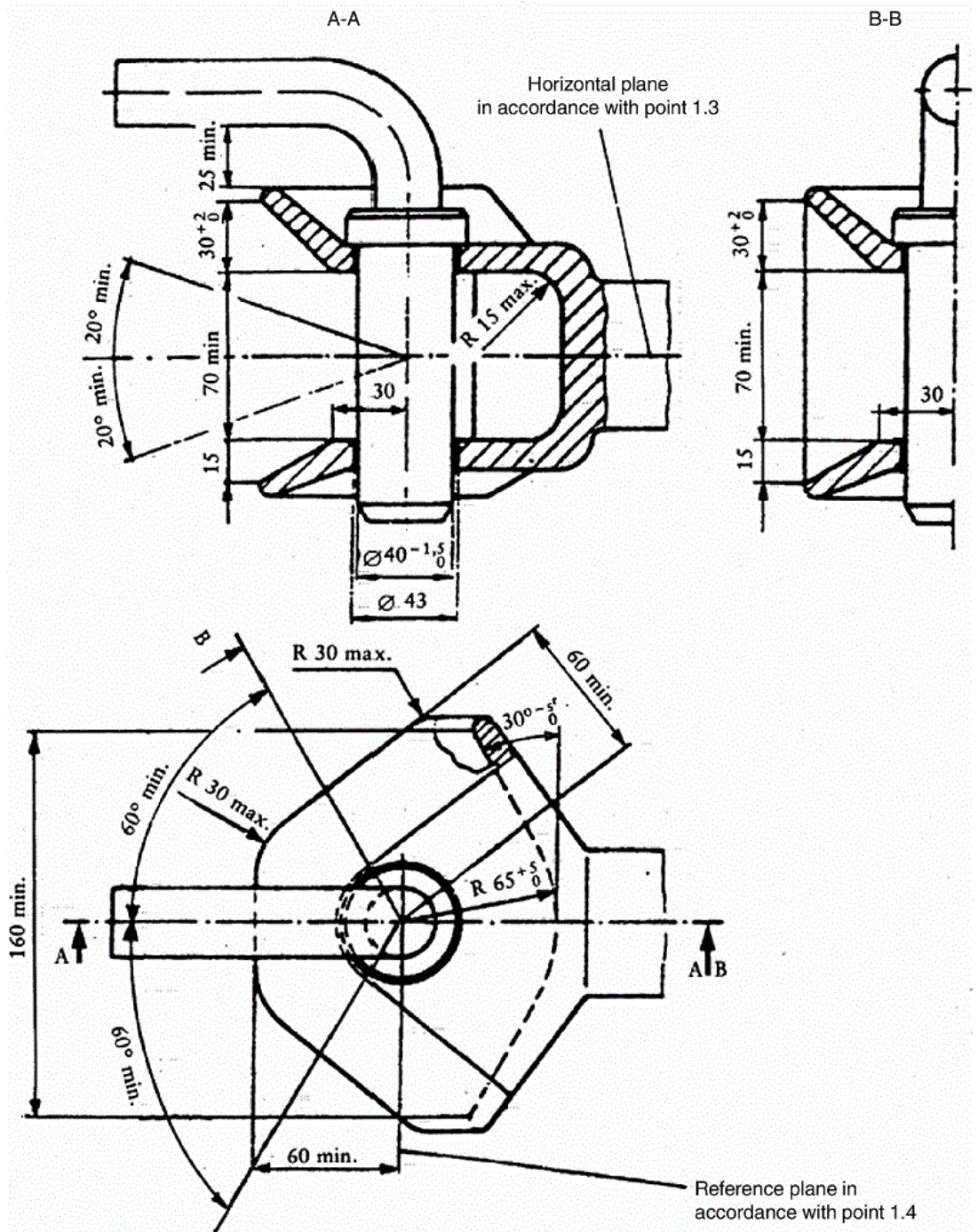

Figure 2 — Non-automatic trailer coupling corresponding to ISO 6489 Part 2 of July 2002

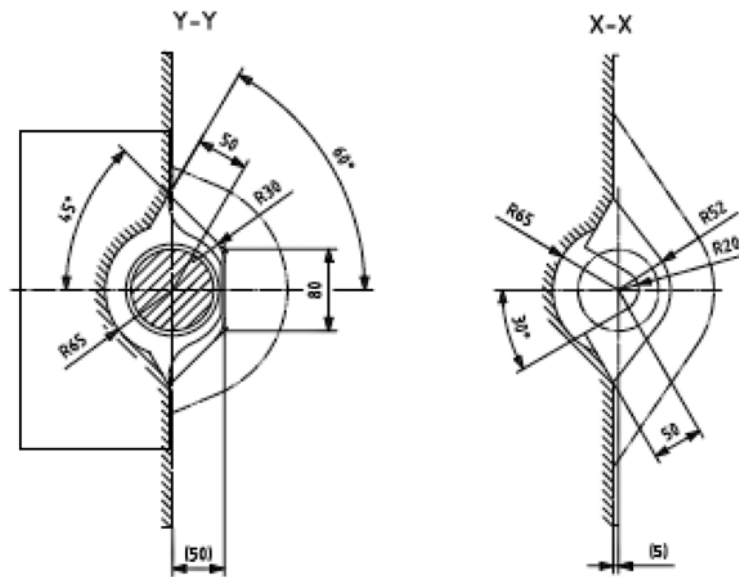
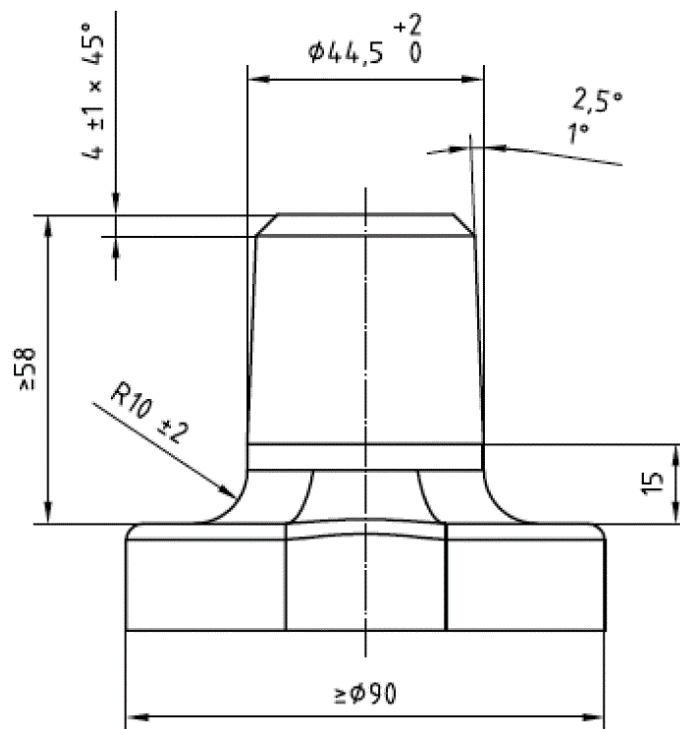

Figure 4 – Ball type coupling (corresponding to ISO 24347:2005)



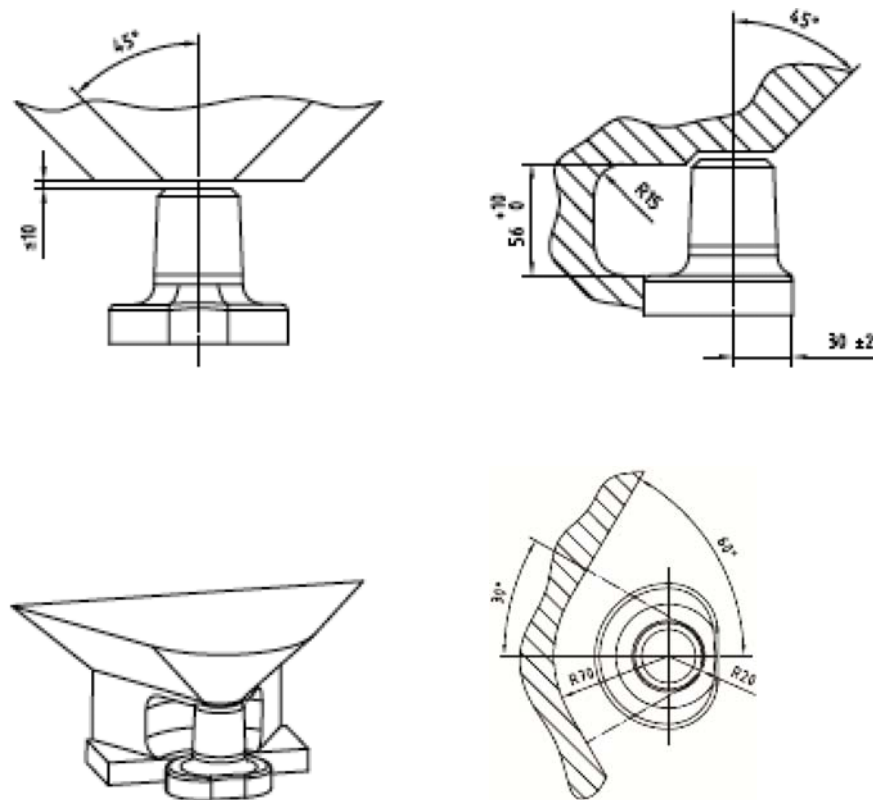

Figure 5 – Pin type coupling (corresponding to ISO 6489-4:2004)

Table 2	
<i>Coupling component on the tractor</i>	<i>Coupling component on the towed vehicle</i>
Corresponding to ISO 6489-1:2001 (hook type)	Corresponding to ISO 5692-1:2004 (hitch ring, 50 mm hole centre, 30 mm ring diameter) or to ISO 20019:2001 (hitch ring, 50 mm hole centre, 30 to 41 mm ring diameter) or to ISO 5692-3:2011 (swivel hitch rings; compatible only with shape Y, 50 mm hole)
Corresponding to ISO 6489-5:2011 (no swivel clevis coupling)	Corresponding to ISO 5692-3:2011 (swivel hitch rings)
Corresponding to ISO 6489-2:2002 (clevis type)	Corresponding to ISO 5692-2:2002 (coupling ring, 40 mm socket) or to ISO 8755:2001 (40 mm drawbar eye) or to ISO 1102:2001 (50 mm drawbar eye, compatible only with ISO 6489-2:2002, shape A – non-automatic)

Corresponding to ISO 6489-3:2004 (drawbar)	Appropriate coupling type mentioned in this column that fits the drawbar dimensions of the tractor mentioned in this Appendix or corresponding to Sa vehicles' hitch rings and attachment to tractor drawbars according to ISO 21244:2008.
Corresponding to ISO 24347:2005 (ball type)	Corresponding to ISO 24347:2005 (80 mm ball diameter)
Corresponding to ISO 6489-4:2004 (piton type)	Corresponding to ISO 5692-1:2004 (hitch ring, 50 mm hole centre, 30 mm ring diameter) or to ISO 5692-3:2011 (swivel hitch rings; compatible only with shape Y, 50 mm hole)

Appendix 2

Mechanical Coupling Dynamic Test Method

1. Test procedure

The strength of the mechanical coupling shall be established by alternating traction on a test bed.

This method describes the fatigue test to be used on the complete mechanical coupling device, i.e. when fitted with all the parts needed for its installation the mechanical coupling is mounted and tested on a test bed.

The alternating forces shall be applied as far as possible sinusoidally (alternating and/or rising) with a load cycle depending on the material involved. No tears or breaks may occur during the test.

2. Test criteria

The horizontal force components in the longitudinal axis of the vehicle together with the vertical force components shall form the basis of the test loads.

In so far as they are of secondary importance, horizontal force components at right angles to the longitudinal axis of the vehicle and also moments shall not be taken into consideration.

The horizontal force components in the longitudinal axis of the vehicle shall be represented by a mathematically established representative force, the value D.

The following equation shall be applied to the mechanical coupling:

$$D = g \cdot (M_T \cdot M_R) / (M_T + M_R)$$

Where:

M_T	=	the technically permissible maximum laden mass of the tractor,
M_R	=	the technically permissible maximum laden mass of the towed vehicles,
g	=	9.81 m/s ² .

The vertical force components at right angles to the track shall be expressed by the static vertical load S .

The technically permissible loads shall be given by the manufacturer.

3. Test procedure requirements

3.1. General requirements

The test force shall be applied to the mechanical coupling device being tested by means of an appropriate standard drawbar ring beneath an angle formed by the position of the vertical test load F_v *vis-à-vis* the horizontal test load F_h in the direction of the median longitudinal plane passing from top front to bottom rear.

The test force shall be applied at the usual point of contact between the mechanical coupling device and the drawbar ring.

The play between the coupling device and the ring shall be kept to a minimum.

In principle the test force is applied in an alternating manner around the zero point. With an alternating test force the resulting load is equal to zero.

Should the design of the coupling device (e.g. excessive play, towing hook) make it impossible to carry out the test with an alternating test load, the test load may also be applied on a rising basis in the direction of traction or pressure, whichever is the greater.

Where the test is carried out with a rising force curve, the test load is equal to the upper (highest) load, and the lower (smallest) load should not exceed 5 % of the upper load.

Care should be taken in the alternating force test to ensure that by suitable mounting of the test apparatus and choice of power conduction system no additional moments or forces arising at right angles to the test force are introduced; the angular error for the direction of force in the alternating force test should not exceed $\pm 1.5^\circ$; and for the rising force test the angle is set in the upper load position.

The test frequency shall not exceed 30 Hz.

For components made of steel or steel casting the load cycle amounts to $2 \cdot 10^6$. The subsequent tear test shall be carried out using the colour penetration method or similar method.

If springs and/or dampers are incorporated into the coupling parts, they shall not be removed during the test but may be replaced if, during the test, they are subject to strain under conditions which would not obtain during normal operation (e.g. heat action) and become damaged. Their behaviour before, during and after the test shall be described in the test

report.

3.2. Test forces

The test force shall consist in geometrical terms of the horizontal and vertical test components as follows:

$$F = \sqrt{(F_h^2 + F_v^2)} \quad \text{where:}$$

$$F_h = \pm 0.6 \cdot D \text{ (kN) in the case of alternating force,}$$

or

$$F_h = 1.0 \cdot D \text{ (kN) in the case of rising force (traction or pressure),}$$

$$F_v = g \cdot 1.5 \cdot S/1000 \text{ (value expressed in kN)}$$

S	=	static drawbar load (load on the track, expressed in kg).
---	---	---

Appendix 3

Mechanical Coupling Static Test Method

1. Test specifications

1.1. General

1.1.1. Subject to a check on its construction characteristics, the mechanical coupling shall undergo static tests in accordance with the requirements of points 1.2, 1.3 and 1.4.

1.2. Test preparation

The tests shall be carried out on a special machine, with the mechanical coupling and any structure coupling it to the body of the tractor attached to a rigid structure by means of the same components used to mount it on the tractor.

1.3. Test instruments

The instruments used to record loads applied and movements shall have the following degree of accuracy:

- loads applied ± 50 daN,
- movements ± 0.01 mm.

1.4. Test procedure

1.4.1. The coupling device shall first be subjected to a pre-traction load which does not exceed 15% of the traction test load defined in point 1.4.2.

1.4.1.1. The operation described in point 1.4.1 shall be repeated at least twice, starting with a zero load, which is gradually increased until the value prescribed in point 1.4.1 is reached, and then decreased to 500 daN; the settling load shall be maintained for at least 60 seconds.

1.4.2. The data recorded for plotting the load/deformation curve under traction, or the graph of that curve provided by the printer linked to the traction machine, shall be based on the application of increasing loads only, starting from 500 daN, in relation to the reference centre of the coupling device.

There shall be no breaks for values up to and including the traction test load which is established as 1.5 times the technically permissible trailer mass; in addition, the load/deformation curve shall show a smooth progression, without irregularities, in the interval between 500 daN and 1/3 of the maximum traction load.

1.4.2.1. Permanent deformation is recorded on the load/deformation curve in relation to the load of 500 daN after the test load has been brought back to that value.

1.4.2.2. The permanent deformation value recorded shall not exceed 25 % of the maximum elastic deformation occurring.

1.5. The test referred to in point 1.4.2 shall be preceded by a test in which an initial load of three times the maximum permissible vertical force (in daN, equal to $g \cdot S/10$) recommended by the manufacturer is applied in a gradually increasing manner, starting from an initial load of 500 daN, to the reference centre of the coupling device.

During the test, deformation of the coupling device shall not exceed 10 % of the maximum elastic deformation occurring.

The check is carried out after removing the vertical force (in daN, equal to $g \cdot S/10$) and returning to the initial load of 500 daN.