



Council of the
European Union

Brussels, 21 October 2015
(OR. en)

Interinstitutional File:
2015/0241 (NLE)

13276/15
ADD 1

UD 205

PROPOSAL

From:	Secretary-General of the European Commission, signed by Mr Jordi AYET PUIGARNAU, Director
date of receipt:	20 October 2015
To:	Mr Jeppe TRANHOLM-MIKKELSEN, Secretary-General of the Council of the European Union
No. Cion doc.:	COM(2015) 512 final ANNEX 1 - PART 1/2
Subject:	ANNEX ATTACHMENT to the Proposal for a Council Decision on the position to be adopted on behalf of the European Union within the Administrative Committee for the TIR Convention as regards the proposal to amend the Customs Convention on the international transport of goods under cover of TIR carnets

Delegations will find attached document COM(2015) 512 final ANNEX 1 - PART 1/2.

Encl.: COM(2015) 512 final ANNEX 1 - PART 1/2



EUROPEAN
COMMISSION

Brussels, 20.10.2015
COM(2015) 512 final

ANNEX 1 – PART 1/2

ANNEX

ATTACHMENT

to the

Proposal for a Council Decision

on the position to be adopted on behalf of the European Union within the Administrative Committee for the TIR Convention as regards the proposal to amend the Customs Convention on the international transport of goods under cover of TIR carnets

AMENDMENTS TO THE CUSTOMS CONVENTION ON THE INTERNATIONAL TRANSPORT OF GOODS UNDER COVER OF TIR CARNETS (TIR CONVENTION 1975)

Annex 6, new Explanatory Note 0.42 bis

Add a new Explanatory Note to Article 42 bis to read as follows:

“0.42 bis The term “immediately” in Article 42 bis is understood to mean that national measures that may affect the application of the TIR Convention and/or functioning of the TIR system, ought to be communicated in writing to the TIRExB as soon as possible and, if possible, prior to its entry into force so as to allow the TIRExB to efficiently discharge its supervisory functions and fulfil its responsibility to examine the measure as to its conformity with the TIR Convention in accordance with Article 42 bis and its Terms of Reference as laid down in Annex 8 of the TIR Convention.”

Annex 2, Article 4, paragraph 2, (i)

For the existing text *substitute*(i) The sliding sheets, floor, doors and all other constituent parts of the load compartment shall be assembled either by means of devices which cannot be removed and replaced from the outside without leaving obvious traces, or by such methods as will produce a structure which cannot be modified without leaving obvious traces.

Annex 2, Article 4, paragraph 2, (iii)

For the existing text *substitute*

(iii) The sliding sheet guidance, sliding sheet tension devices and other movable parts shall be assembled in such a way that when closed, and Customs sealed, doors and other movable parts cannot be opened or closed from the outside without leaving obvious traces. The sliding sheet guidance, sliding sheet tension devices and other movable parts shall be assembled in such a way that it is impossible to gain access to the load compartment without leaving obvious traces once the closing devices have been secured. An example of such a system of construction is given in sketch No. 9 appended to these Regulations.

Annex 2, new Article 5

After the modified Article 4 *insert*

Article 5

Vehicles with a sheeted sliding roof

1. Where applicable, the provisions of Articles 1, 2, 3 and 4 of these Regulations shall apply to vehicles with a sheeted sliding roof. In addition, these vehicles shall conform to the provisions of this Article.
2. The sheeted sliding roof shall fulfil the requirements set out in (i) to (iii) below.
 - (i) The sheeted sliding roof shall be assembled either by means of devices which cannot be removed and replaced from the outside without leaving obvious traces, or by such methods as will produce a structure which cannot be modified without leaving obvious traces.
 - (ii) The sliding roof sheet shall overlap with the solid part of the roof at the front side of the load compartment, so that the roof sheet cannot be pulled over the top edge of the upper cantrail. In the length of the load compartment, at both sides, in the hem of the roof sheet, a pre-stressed steel cable shall be inserted in such a way that it cannot be removed and re-inserted without leaving obvious traces.

The roof sheet shall be secured to the sliding carriage in such a way that it cannot be removed and re-secured without leaving obvious traces.

- (iii) The sliding roof guidance, the sliding roof tension devices and other movable parts shall be assembled in such a way that when closed, and Customs sealed, doors, roof and other movable parts cannot be opened or closed from the outside without leaving obvious traces. The sliding roof guidance, sliding roof tension devices and other movable parts shall be assembled in such a way that it is impossible to gain access to the load compartment without leaving obvious traces once the closing devices have been secured.

An example of a possible system of construction is shown in sketch No.10, appended to these Regulations.

Annex 2, Sketch No. 9

For the existing Sketch No. 9 *substitute*

Sketch No. 9

EXAMPLE OF A CONSTRUCTION OF A VEHICLE WITH SLIDING SHEETS

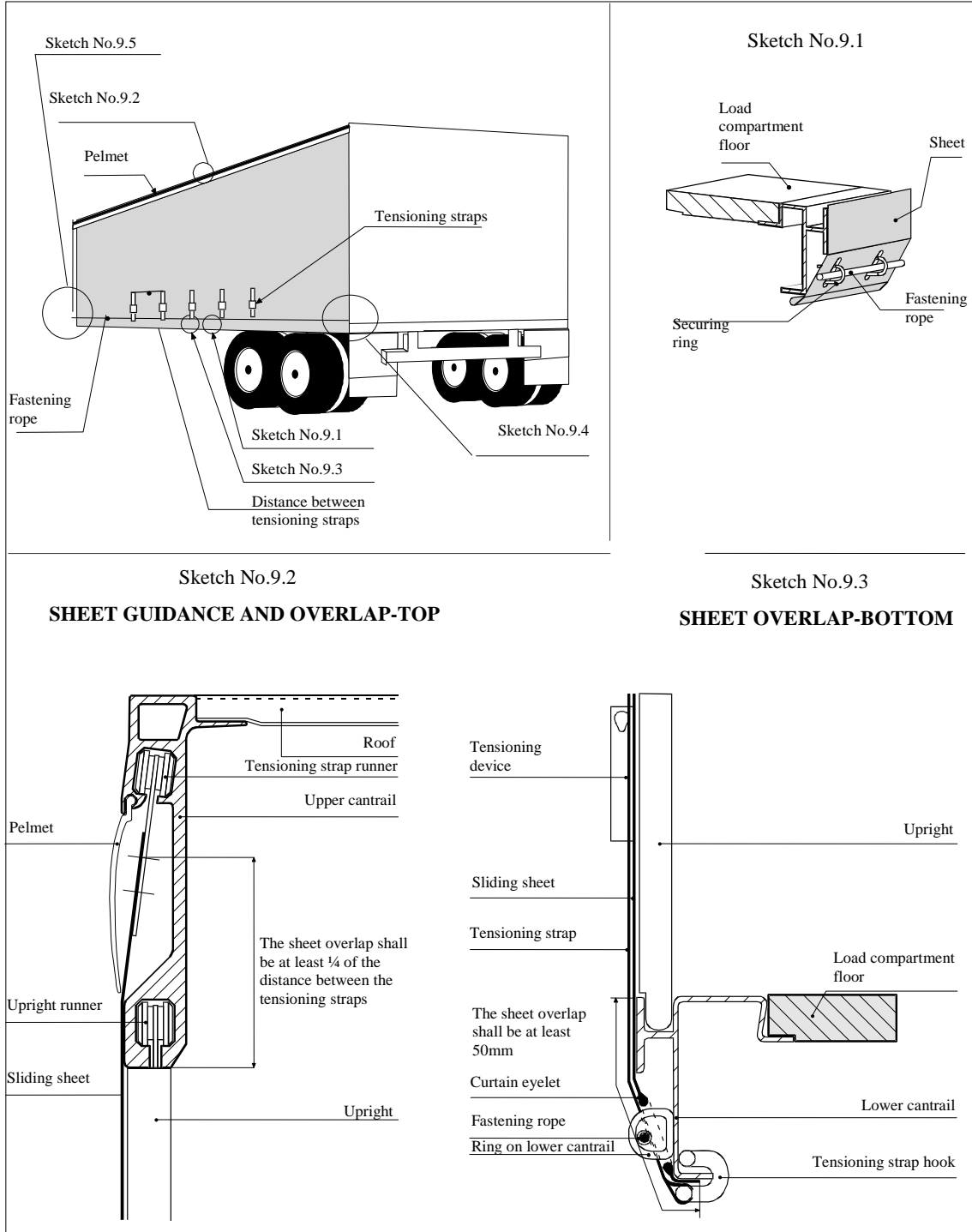

Sketch No. 9.4

To tighten the sliding sheets in the horizontal direction, a ratchet gear is used (normally at the rear end of the vehicle). This sketch shows two examples, (a) and (b), of how the ratchet or gearbox may be secured.

(a) Ratchet securing

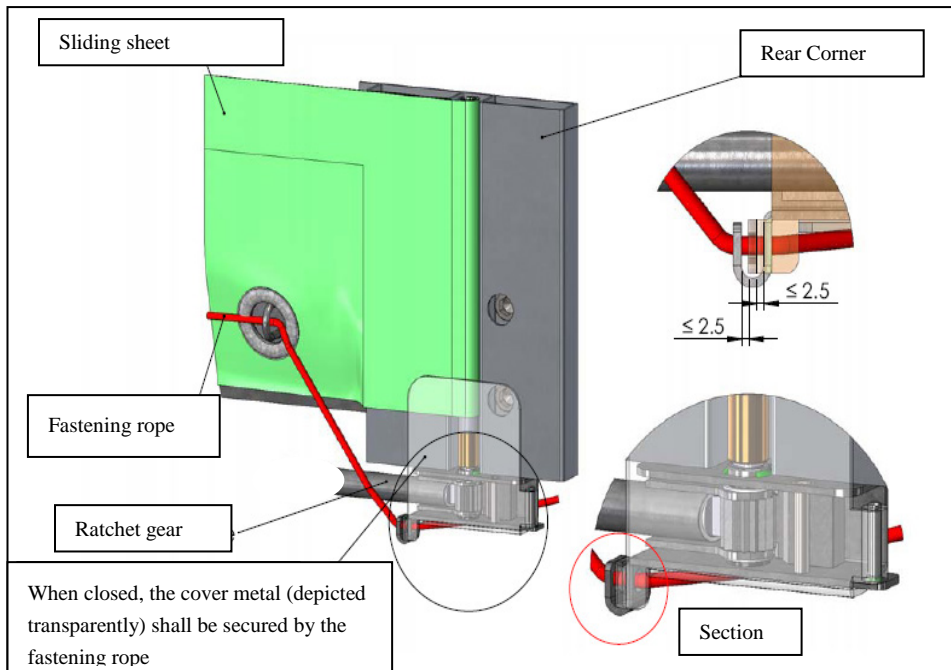

(b) Gearbox securing

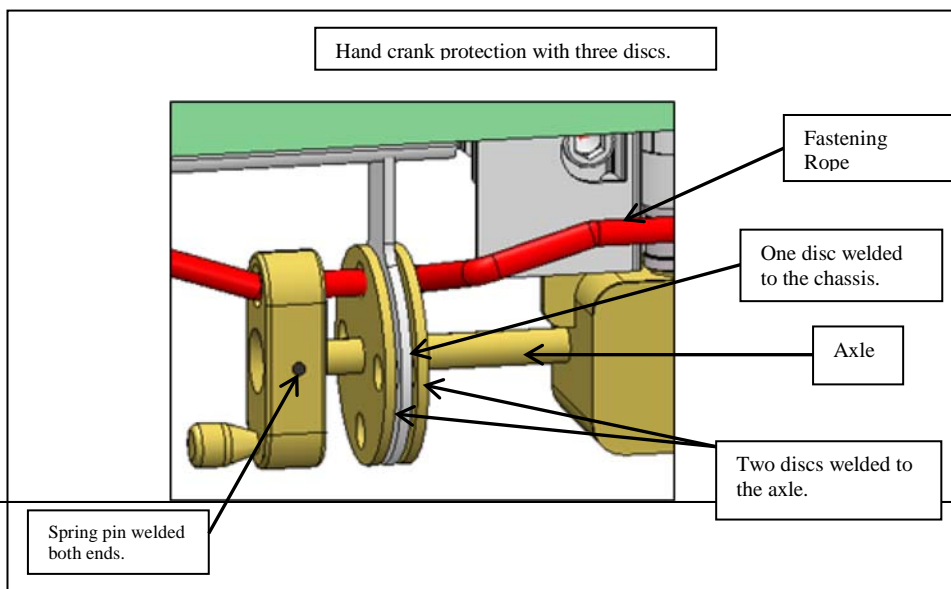

Sketch No. 9.5

To fix the sliding sheet on the other side (normally the front of the vehicle), the following systems, (a) or (b), may be used.

(a) Cover metal

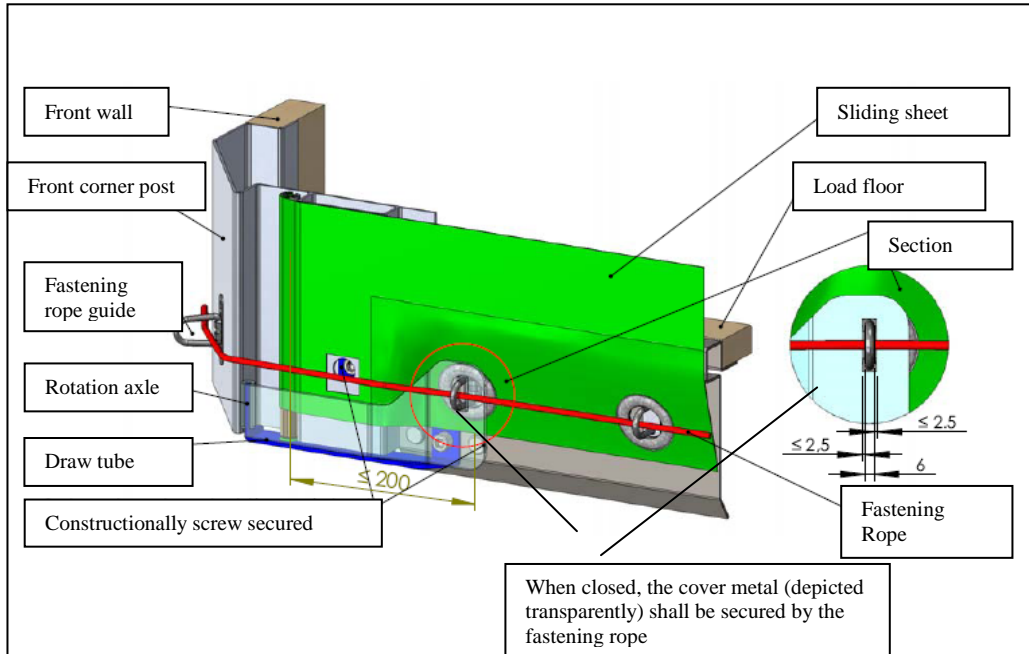

(b) Narrow oval eyelet, anti-lifting system for the tensioning tube

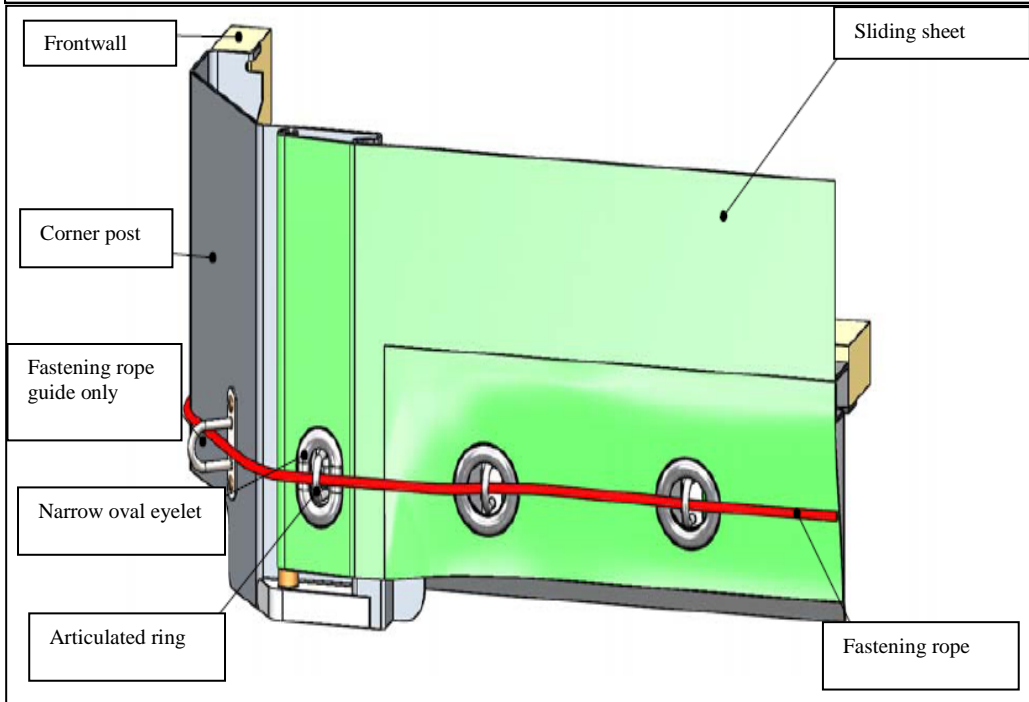

Annex 2, new Sketch No. 10

After new Sketch No. 9 insert

Sketch No. 10

**EXAMPLE OF A CONSTRUCTION OF A VEHICLE WITH A SHEETED
SLIDING ROOF**

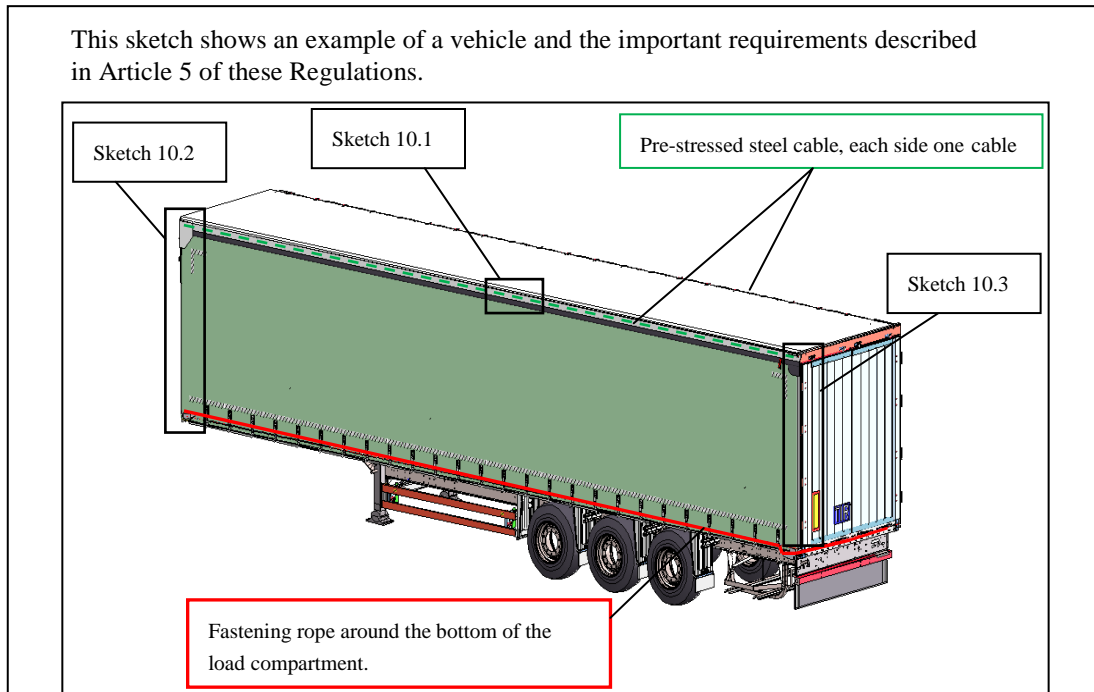

Sketch No. 10.1

Two pre-stressed steel cables, embedded in a hem, are fixed on each side of the load compartment. This pre-stressed steel cable is fixed to the front (see sketch 10.2) and rear of the body (see sketch 10.3). The tractive force as well as the connecting disc on each sliding carriage makes it impossible to lift up the hem with the pre-stressed steel cable above the upper cantrail.

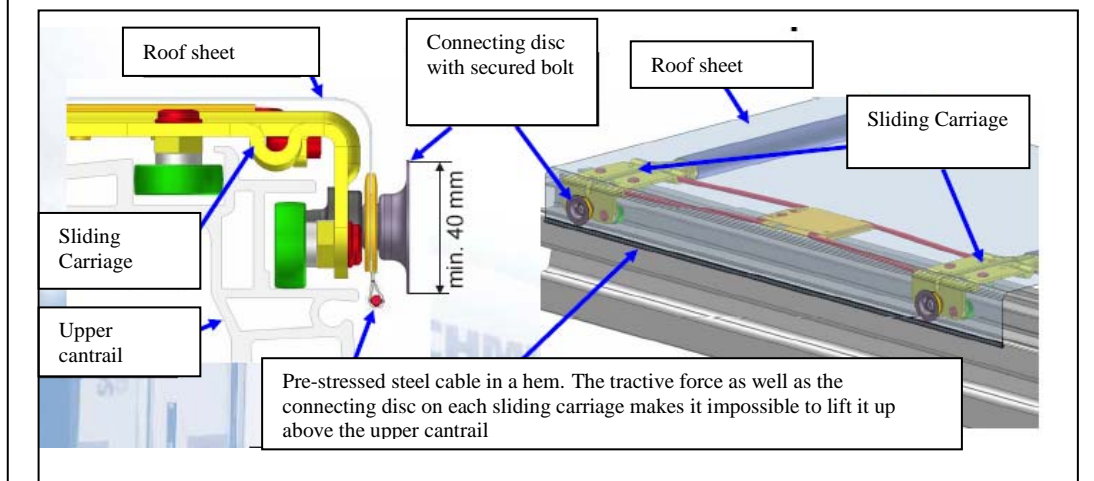

Sketch No.10.2

The sliding roof sheet shall overlap with the solid part of the roof at the front side of the load compartment, so that the roof sheet cannot be pulled over the top edge of the upper cantrail.

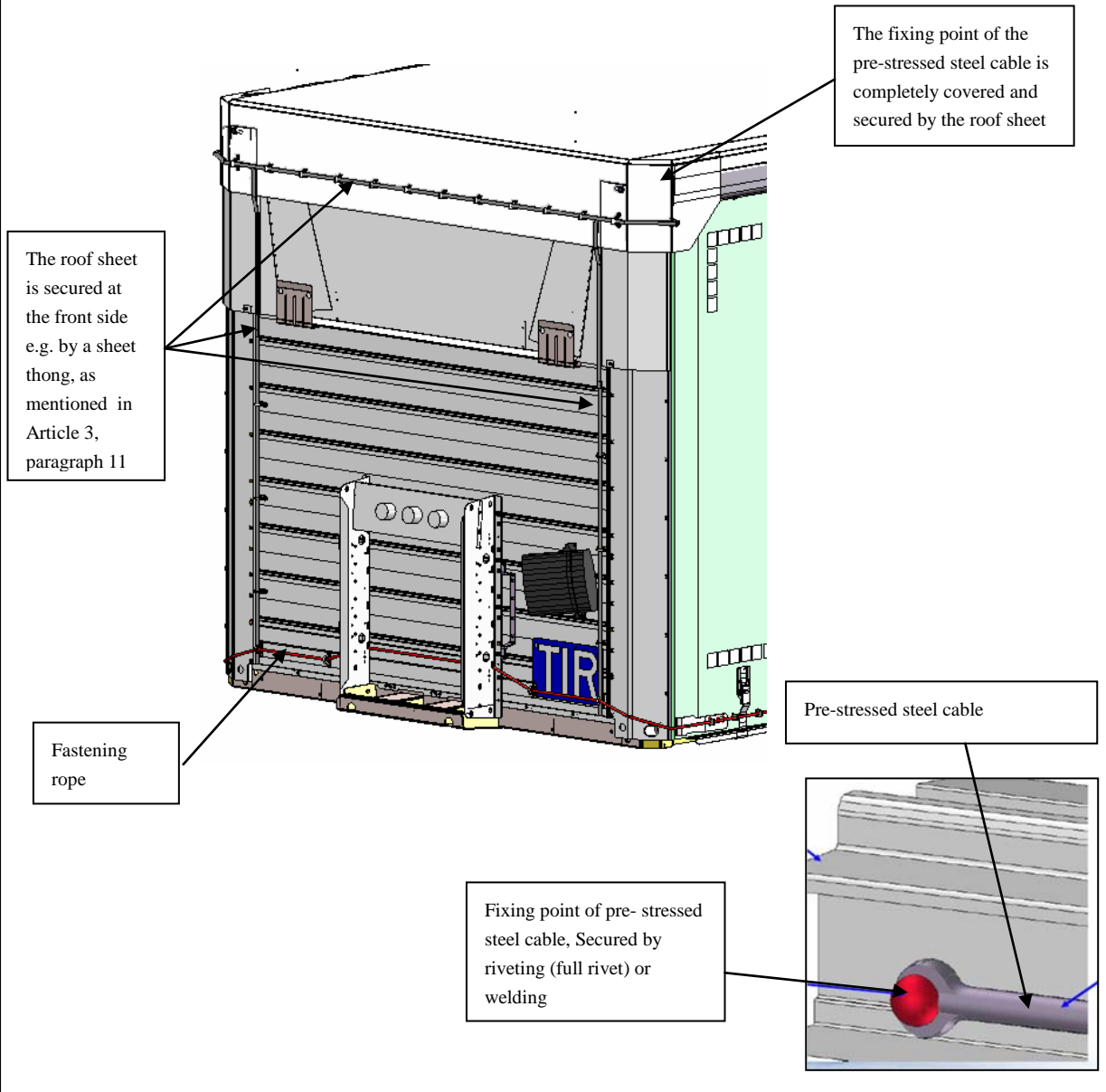

Sketch No.10.3

At the rear, a special device, such as a baffle plate, is fitted to the roof, preventing access to the container, without leaving obvious traces when the doors are closed and sealed.

