



Brussels, 29 May 2019  
(OR. en)

9609/19

MAR 118  
OMI 49  
ENV 507

## 'I' ITEM NOTE

---

From:	General Secretariat of the Council
To:	Permanent Representatives Committee
No. Cion doc.:	9524/19 MAR 115 OMI 46 ENV 501 9525/19 MAR 116 OMI 47 ENV 502
No. prev. doc.:	9597/19 MAR 117 OMI 48 ENV 505 + ADD 1 + ADD 2
Subject:	IMO - Union submission and INF paper to be submitted to the 6th session of the Sub-Committee on Carriage of Cargoes and Containers (CCC 6) of the IMO, taking place in London from 9 – 13 September 2019, concerning the results of a Formal Safety Assessment study on the use of low-flashpoint diesel as a marine fuel within the scope of the International Code of Safety for Ships Using Gases or Other Low-flashpoint Fuels (IGF Code) and draft amendments to the IGF Code to regulate the use of such fuels – <i>Endorsement</i>

---

## INTRODUCTION

1. On 20 May 2019, the Commission transmitted to the Council two Staff Working Documents containing a draft submission and a draft information paper to the 6th session of the Sub-Committee on Carriage of Cargoes and Container ('CCC 6') of the International Maritime Organization ('IMO') concerning the results of a Formal Safety Assessment ('FSA') study on the use of low-flashpoint diesel as a marine fuel within the scope of the International Code of Safety for Ships Using Gases or Other Low-flashpoint Fuels ('the IGF Code') as well as draft amendments to the IGF code to regulate the use of such fuels. The deadline for transmitting the draft submissions to the IMO Secretariat is 7 June 2019.

2. The aim of the FSA study is to identify potential additional hazards, assess related risks and identify potential risk control measures to achieve safety equivalence for one representative low-flashpoint diesel with a flashpoint of 52°C or above and less than 60°C, in comparison to conventional maritime diesel. The use of low-flashpoint fuels is in line with general objectives to encourage and facilitate the uptake of alternative fuels, but any safety concerns need to be taken seriously.

## **WORK WITHIN THE COUNCIL**

3. The draft submissions were examined by the Shipping Working Party at its meetings on 22 and 29 May 2019. Based on the discussions at that last meeting, minor changes have been made to the draft submissions for clarification purposes; there was, however, unanimous agreement on the substance of the documents. It was also agreed that the Presidency would be allowed to indicate at the time of transmission that the documents may be released to the public by the IMO secretariat prior to CCC 6.
4. It should be noted that some delegations did not agree with one of the legal bases the Commission had indicated in support of its claim for EU exclusive competence, namely the references in the Commission Staff Working Documents to Directive 2014/94/EU of the European Parliament and of the Council of 22 October 2014 on the deployment of alternative fuels infrastructure.
5. While there is agreement on the substance of the draft submissions, there is no agreement on who should submit them. The Commission maintains the view that the draft submissions should be made by "the European Commission on behalf of the European Union", while the Member States consider that the submissions should be made by the Member States and the European Commission.
6. Given the urgency and importance of the matter, it was agreed at working party level to propose to transmit the submissions in the name of the Member States and the European Commission, while taking good note of the position of the Commission.

## CONCLUSION

7. In the light of the above, the Permanent Representatives Committee is invited to
    - endorse the text of the draft submissions in the annex, with a view to their transmission by the Presidency to the International Maritime Organization by 7 June 2019.
-

SUB-COMMITTEE ON CARRIAGE OF  
CARGOES AND CONTAINERS  
6th session  
Agenda item 3

CCC 6/3/X  
8 June 2018  
Original: ENGLISH  
Pre-session public release:

**AMENDMENTS TO THE IGF CODE AND DEVELOPMENT OF  
GUIDELINES FOR LOW-FLASHPOINT FUELS**

**FSA Study on the use of low-flashpoint diesel as a marine fuel  
within the scope of the IGF Code and draft amendments to the IGF Code**

**Submitted by Austria, Belgium, Bulgaria, Croatia, Cyprus, the Czech Republic, Denmark,  
Estonia, Finland, France, Germany, Greece, Hungary, Ireland, Italy, Latvia, Lithuania,  
Luxembourg, Malta, the Netherlands, Poland, Portugal, Romania, Slovakia, Slovenia, Spain,  
Sweden, the United Kingdom and the European Commission**

**SUMMARY**

*Executive summary:* This document presents a FSA study on safety-related issues for the potential use of low-flashpoint oil fuels as a marine fuel as well as draft amendments to the IGF Code to regulate the use of such fuels.

*Strategic Direction, if applicable:* 2

*Output:* 2.3

*Action to be taken:* Paragraph 4

*Related documents:* MSC.391(95); CCC 2/15; SOLAS II-2; CCC 4/3/5, CCC 4/INF.11, CCC 4/12; CCC 5/3/4; CCC 6/INF.XX

## Introduction

1 This document is submitted in view of the discussion on the use of low-flashpoint diesel in the context of SOLAS chapter II-2 and the IGF Code (resolution MSC.391(95)). As discussed at MSC 94, MSC 95, MSC 96, MSC 98, CCC 2, CCC 4 and CCC 5, provisions should be made to allow for the use of low-flashpoint diesel. It was decided that such a discussion would take place in the context of this output.

2 In support of the further debate on the safe use of low-flashpoint diesel as a fuel on ships to which SOLAS and the IGF Code apply, an FSA study on the safe use of low-flashpoint diesel as a marine fuel was carried out. A summary of this study is set out in annex 2. The full report of the FSA study is provided in document CCC 6/INF.XX. **The aim of the study is to provide a comparative risk assessment based on the behaviour of diesel fuels with a flashpoint of 52°C or above and less than 60°C.**

3 The outcome of this study shows that there are only slight differences in the risk of using low-flashpoint diesel fuels compared to conventional oil fuels when it comes to worst case scenarios. These marginal additional risks could be addressed by specific regulations in the IGF Code. The first draft, based on the recommendations of the FSA study, for such regulations is set out in annex 1.

### Action requested of the Sub-Committee

4 The Sub-Committee is invited to note the executive summary of the study provided in annex 2 and to consider the proposal for a new, fuel-related chapter of the IGF Code as set out in annex 1, and take action as appropriate.

\*\*\*

## ANNEX 1

### DRAFT PART A-2

#### **SPECIFIC REQUIREMENTS FOR SHIPS USING OIL FUEL WITH A FLASHPOINT OF 52°C OR ABOVE AND LESS THAN 60°C**

Fuel in the context of the regulations in this part means oil fuel with a flashpoint of 52°C or above and less than 60°C.

#### 20 Ship design, arrangement and equipment

##### 20.1 Goal

The goal of this chapter is to provide for safe location, space arrangements and protective equipment for ships using low flashpoint oil fuel.

##### 20.2 Functional requirements

20.2.1 This chapter is related to functional requirements in 3.2.1, 3.2.11, 3.2.17 and 3.2.18.

##### 20.3 Regulations

The following regulations apply in addition to the regulations for machinery and machinery spaces of category A of the Convention.

20.3.1 Fuel tanks except those arranged in double bottom compartments shall be located outside of machinery spaces of category A;

20.3.2 Equipment for the measurement of oil temperature shall be provided on the suction pipe of the fuel pump;

20.3.3 Stop valves and/or cocks shall be provided on the inlet side and outlet side of the oil fuel strainers;

20.3.4 Pipe joints of welded construction or of circular cone type or spherical type union joint shall be applied as far as reasonably practicable

20.3.5 Bilge systems installed in areas with LFPD fuel installations shall be segregated from other bilge systems.

20.3.6 Other tanks containing fuel, e.g. drain tanks, shall not be located within machinery spaces or within accommodation spaces.

## ANNEX 2

### FORMAL SAFETY ASSESSMENT OF LOW-FLASHPOINT DIESEL FUEL

#### 1. EXECUTIVE SUMMARY

Following the IMO discussions on the use of automotive diesel for shipping, the German *Federal Ministry of Transport and Digital Infrastructure* (BMVI) initiated a study on the identification of potential additional hazards for the use of diesel with a flashpoint below 60°C in shipping. According to IMO's SOLAS Convention, the use of maritime liquid fuels is limited to fuels with a flashpoint equal or above 60°C<sup>1</sup> and thus usage of automotive diesel with flashpoint below this threshold is prohibit.

The aim of this study is to identify potential additional hazards, assess related risks and identify potential risk control measures to achieve safety equivalence for one representative low-flashpoint diesel with a flashpoint of 52°C or above and less than 60°C, in comparison to conventional maritime diesel.

This risk-based analysis is orientated on IMO's guidelines for Formal Safety Assessment (FSA) of 2018 /1/. As recommended by these guidelines a Hazard Identification (HazId) was conducted to identify potential additional hazards related to the usage of low-flashpoint diesel in comparison to conventional maritime diesel fuels. The characterization by OWI of diesel fuel with and without flashpoint below 60°C is considered in the HazId. The results of the HazId are summarized in Chapter 6.2 of this report.

Following the IMO FSA guidelines /1/ a further analysis for scenarios identified within the HazId were performed in terms of a Risk Assessment including experimental investigations, CFD simulations, numerical calculations and event sequence analysis. The results of this Risk Assessment can be found in Chapter 7.6 of this report.

The Risk Assessment showed no difference in the ignition behaviour between a diesel fuel with FP 52°C and one with FP 60°C. Slight differences in the evaporation behaviour were determined during experimental measurements. Via the CFD-simulations it could be demonstrated that even under worst case boundary conditions the likelihood for a flammable atmosphere inside the fuel tank or in the machinery space is not significantly increased by fuels with a lower flashpoint than 60°C. Further, for the ignition behaviour of different fuels with different flashpoints no significant differences regarding the autoignition temperature and the ignition on hot surfaces could be identified. The risk level of the use of low-flashpoint diesel is assessed to be equivalent to conventional maritime diesel fuel systems. Further Risk Control Options are recommended in in chapter 8 in order to prevent uncertainties for worst case scenarios. Further recommendation are made in chapter 10 to avoid inconsistencies in the current rule frame work.

#### **Actions to be taken**

Based on results of this risk assessment risk control options (RCOs) are identified that are listed in Chapter 8 of this report.

#### **Related documents**

A first study on "Safety relevant properties of low flashpoint diesel fuels" was carried out by the companies ThyssenKrupp Marine Systems and the OWI in June 2016.

---

<sup>1</sup> In the following "conventional marine diesel fuel".

An information document CCC 4/INF.11 of this study was submitted to the IMO sub-committee on carriage of cargoes and containers in July 2017.

## INTRODUCTION

Reducing pollutant emissions caused by maritime shipping is a key objective of the German Federal Government's climate policy. The use of alternative fuels, e.g. Liquefied Natural Gas (LNG) or automotive diesel on board ships has been discussed at IMO for several years.

As one result, it was decided under international law to limit the sulphur content of marine fuels to 0.5% from 01.01.2020 (MARPOL Annex VI, Rule 14), which means that a large proportion of currently used fuels is no longer permitted without after treatment of the emissions. Alternative fuels which are fulfilling the emission targets of the existing and upcoming regulations are generally available, but SOLAS requires in Chapter II-2 Rule 4 2.1.1 that the flashpoint of fuels used on board seagoing vessels may not be less than 60°C which limits the range of fuels. Exceptions for fuels with a flashpoint less **than** 60°C are regulated in the IGF Code but fuels, such as automotive diesel has not yet been included. Automotive diesel has a lower flashpoint of at least 55°C in the EU and 52°C in the US.

In view of allowing the usage of low flashpoint on seagoing vessel, this study focus on an identification and assessment of the additional risk of using low flashpoint diesel, and, if necessary, identify risk control measure to reach safety equivalency.

The starting point for this is a study by the Oel-Wearme-Institut (OWI), affiliated institute of the RWTH Aachen, in which, the physical properties of fuels with different flashpoints were determined and evaluated /2/.

The study is performed considering IMO Formal Safety Assessment (FSA) guideline /1/.

For the identification of additional hazards a generic model for a representative generic machinery space model is used, operated with two different diesel fuels with a flashpoint of 52°C and 60°C (Chapter 4). In the HazId standard operation and accidental situations were discussed and probability and consequences estimated by experts (Chapter 6). Subsequently, scenarios with noticeable additional consequences due to the flashpoint differences are selected for further consideration in step 2 the risk assessment, including experimental investigations of the ignition and evaporation behaviour of diesel fuels and CFD simulations (Chapter 7). To reduce potential additional risks due to the use of Low-Flashpoint diesel to the equivalent risk level of conventional diesel fuel Risk Control Measures (RCMs) will be identified (FSA step 3; chapter 8) and their costs and benefits assessed (FSA step 4; chapter 9). The study ends with recommendations (FSA step 4) to further consideration (Chapter 10).

## AIM OF THIS STUDY

The aim of this study is to provide a comparative risk assessment based on the behaviour of diesel fuels with a flashpoint of 52°C **or above** and **less than** 60°C.



## STUDY BASELINE / BACKGROUND

### Safety relevant properties of diesel fuels

The safety relevant properties of diesel fuels were assessed during a first study by the OWI [2]. Important are the characteristics for the formation and ignition of explosive atmospheres. The most important safety relevant properties are the flashpoint (FP), explosion limits (EL), explosion points (EP) and auto ignition temperatures (AI). The upper and lower explosion limits (UEL, LEL; critical concentrations) and upper and lower explosion points (UEP, LEP; critical temperatures) are physically related to each other by the vapour pressure curve, thus forming a well-defined region under which an explosive atmosphere does occur (see Figure 1).

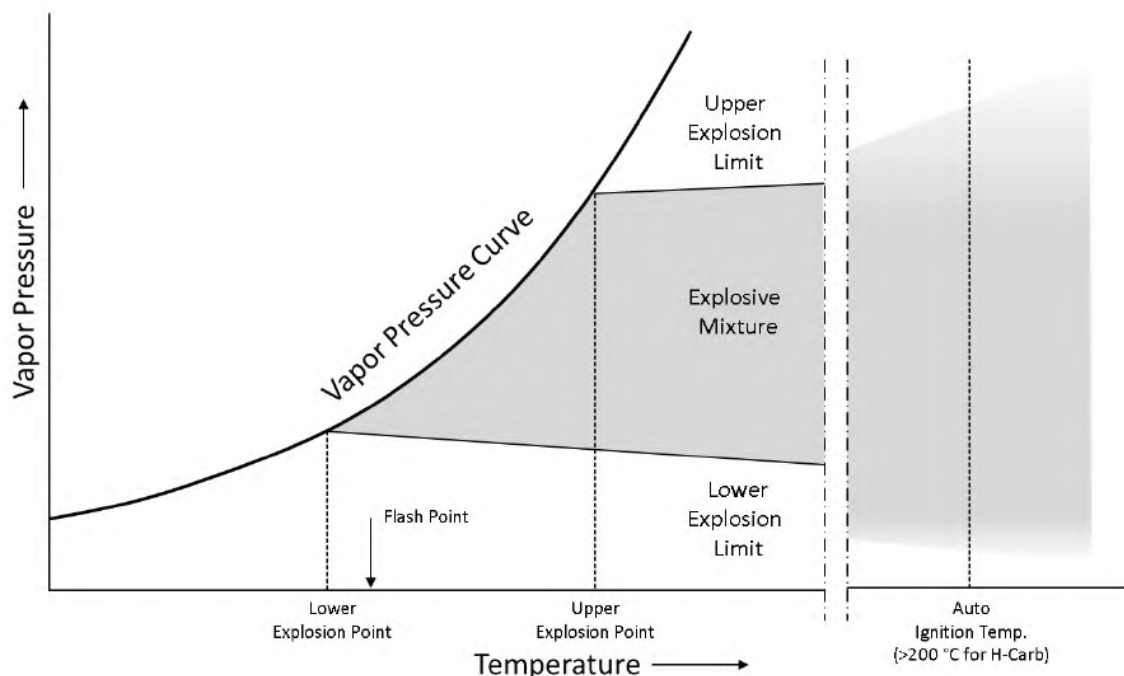

**Figure 1: Vapour pressure and temperature relation**

The FP of a diesel fuel is mainly depending on the saturated vapour pressure of the hydro-carbons and does not correlate to the auto ignition temperature. However, the chain length and structure of the hydrocarbons of diesel fuels give an indication of the auto ignition temperature, e. g. long chain length of homologous series of n-alkanes decreases the auto ignition temperature in comparison to short-chain length n-alkanes. The safety parameters UEL/UEP and LEL/LEP provide a sound basis to evaluate, whether an atmosphere at a certain temperature is explosive or not. For liquid fuels the critical area is limited by the saturation pressure in the low temperature range. The FP shows if a liquid fuel can generally form an ignitable atmosphere considering saturated vapour pressure of the fuel and the minimum ignition energy. However, it is noted that the explosion points and explosion limits should be considered in addition as they provide a more complete set of parameters considering concentration and related temperature of the explosive mixture.

Another important safety aspect is the time needed to form an explosive mixture which cannot be judged from the static parameter set FP/EP/EL. For that reason, in addition to the differences in the standard parameters, the differences in the evaporation rates must be studied.

## Regulations affected by using low-flashpoint diesel fuels

The current regulations allow the use of oil fuels with a flashpoint equal or above 60°C according to SOLAS Chapter II-2 regulation 4, Para. 2.1.1 /3/. The use of automotive diesel with a flashpoint of 52°C<sup>1</sup> is not permitted, except for cases handled by SOLAS Chapter II-2 regulation 4, Para. 2.1.5 referring to the requirements of SOLAS Chapter II-1 Part G regulation 56 and 57. According to these regulations, ships other than gas carriers need to comply with the requirements of the IGF Code.

For the time being the IGF Code does not provide requirements for the use of low-flashpoint diesel as fuel. However, according to IGF Code Section 2.3.2 an approval of low-flashpoint diesel fuel systems is possible based on the alternative design process (SOLAS regulation II-1/55).

Exceptions for the use of oil fuel having a flashpoint less than 60°C are made for e.g. feeding the emergency pump's engines and auxiliary machine. Corresponding requirements are defined in SOLAS Ch. II-2/2; Sec. 2.1.3.

## Definition of reference diesel fuels

For this study two reference diesel fuels with a flashpoint of 60°C and 52°C have been selected and investigated in detail. The diesel fuel with flashpoint 60°C is a commercial available diesel fulfilling the specifications acc. DIN EN 590 /4/ for automotive diesel and ISO 8217 /5/ for marine diesel. The low-flashpoint diesel fuel with a flashpoint of 52°C was blended from that diesel and a diesel-like fuel with a flashpoint of 43°C, and is fulfilling the specifications acc. to DIN EN 590 as well except flashpoint. The diesel-like fuel with a flashpoint of 43°C is also tested in the study to have a third set of parameters for the identification of trends in the results.

## Definition of a generic diesel fuel system model

For the comparative study a generic engine room model is designed (see Figure 2) which represents a typical size and arrangement for a vessel operating with marine diesel oil based on existing designs. This generic machinery space concept is used for further evaluation of the specific fuel behaviour within the HazId workshop, the risk assessment and the CFD simulations as well.

The generic engine room model is shown in Figure 2 without the storage tanks containing the diesel fuels. The reference diesel fuel system is structured in the following sub-systems:

- Storage tank
- Transfer system
- Fuel service system
- Overflow system
- Engine system
- Exhaust gas system

---

<sup>1</sup> Flashpoint limits for automotive diesel are 52°C in the US and 55°C in Europe.

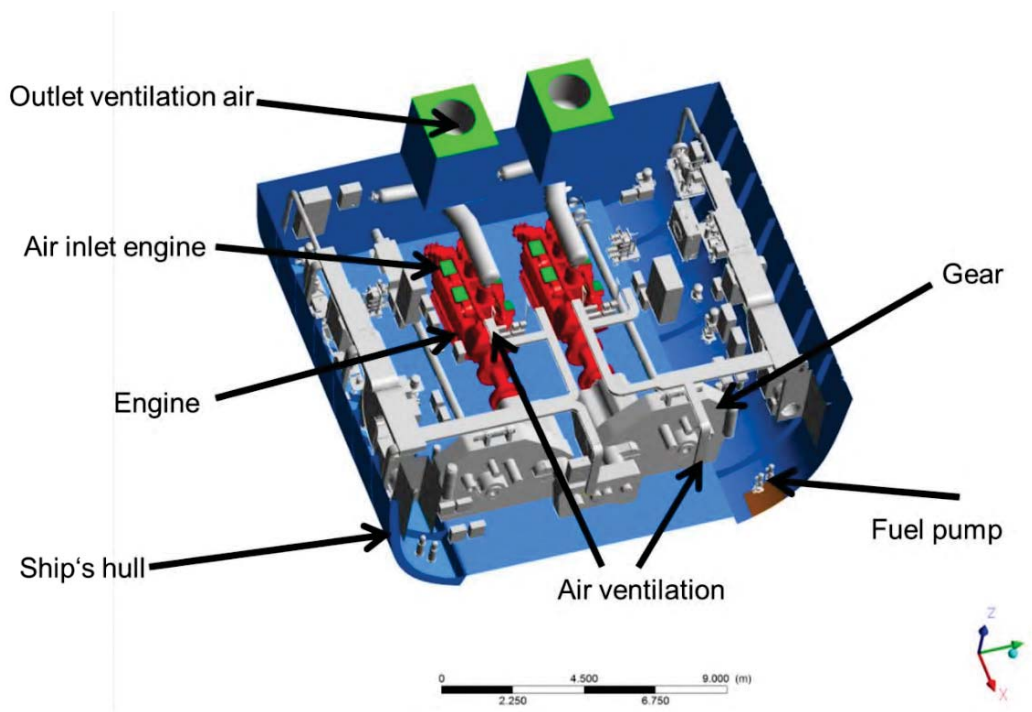

**Figure 2: Reference diesel engine room arrangement (source: tkMS)**

The diesel fuel is transferred by the transfer system from the bunker tanks to the settle tank, which is designed for 24 hours operation. After fuel treatment (separation) the fuel is transferred to the day tank, designed for 8 h of operation, and further to the engines. The overflow system is transferring excessive fuel from the engines into the day tank and the day tank into the settle tank. The vent line of the day and settle tank is routed via the overflow tank to the atmosphere on open deck.

The generic machinery system consists of two 4-stroke diesel engines. These engines are equipped with high-pressure injection provided by high pressure pumps for the fuel. According to current SOLAS requirements the high-pressure parts are double walled, spray shields are provided and the engine room is equipped with a ventilation system.

### **Assumptions and limitations**

The aim of the study is to assess the risk of low flash point diesel by comparing two representative diesel fuels with different flashpoints, i.e. with FP 60°C and FP 52°C. Preparational investigation of fuel oil characteristics and the HazId meeting showed that low flashpoint diesel fuel does not introduce new failure modes for the machinery system. Therefore, increased emphasis is put on investigating the differences of the consequences. For this, worst case scenarios caused by single point failure are considered but not a combination of several failures. Accordingly, the day tank and the pumps for the transfer of fuel are located inside the engine room because it is expected that this configuration will cause the most severe effects due to potential ignition sources and presence of crew in case of a leakage. In reality the design may differ and the day tank can be located adjacent to the engine room which is regarded to be of lower risk.

In view of investigating worst case scenario, for the CFD simulation a scenario with a low ventilation rate of the engine room is considered as in this case higher concentrations of diesel vapour mixture can be expected than for a high ventilated room. Due to the fact that the ventilation rate of the machinery room depends on the combustion air demand of the engine, an engine load of 20% was considered. In this operational point 110% of the combustion air needed for the engine is supplied by the engine room ventilation.

## METHOD OF WORK

### Analysis team

This study is performed by the team members that are listed below including their role, and which belong to a consortium of the companies:

**Table 1 - Core team members of the study**

Name	Company	Role
Lars Langfeldt	DNV GL	Risk Assessment / FSA lead
Stephan Eylmann	DNV GL	Risk Assessment
Dr. Rainer Hamann	DNV GL	Review of Formal safety assessment
Benjamin Scholz	DNV GL	Safety requirements for LFPD fuel installations
Pawel Bittner	OWI	Numerical Tank Simulation
David Diarra	OWI	Diesel fuel specifications and properties
Sebastian Feldhoff	OWI	Diesel fuel specifications and properties
Melanie Grote	OWI	Engine room simulations
Holger Kapahnke	tkMS	Engine room and fuel system design
Keno Leites	tkMS	Engine room and fuel system design

### Methodology

The study is orientated on IMO's guidelines for Formal Safety Assessment (FSA) MSC-MEPC.2/Circ. 12/Rev. 2 /1/. This chapter is intended to give a brief introduction of the methodology for the work documented in this report, for details on the FSA process see /1/.

The overall FSA process is shown Figure 3.

Following the objectives and the prerequisites, based on the FSA guidelines the scope of this study is specified as follows:

- Problem definition;
- Step 1 identification of hazards: identify potential hazards related to the usage of diesel in ship machinery system in general and, in particular, the impact of the flashpoint by means of two representative diesel fuels with flashpoints of 52°C and 60°C. Subsequently, identify main risk contributors for step 2 of the investigation. The HazId is performed as moderated expert session;

- Step 2 risk assessment: based on the outcome of the hazard main risk contributors are investigated in detail, in particular, with respect to factors driving the risk. Risk is evaluated by means of SOLAS compliant design, i.e. diesel fuel with FP 60°C;
- Step 3 identification of risk control options: related to the outcome of the risk evaluation risk mitigating measures are identified, if necessary, aiming on safety equivalence to SOLAS compliant design;
- Step 4 cost-benefit assessment: due to the fact that safety equivalence is the evaluation criterion, application of ALARP principle including cost-benefit assessment is regarded not necessary. Anyway, an indication of potential cost driver is performed; and,
- Step 5 recommendations: recommendation related to the outcome of Step 3 will be developed.

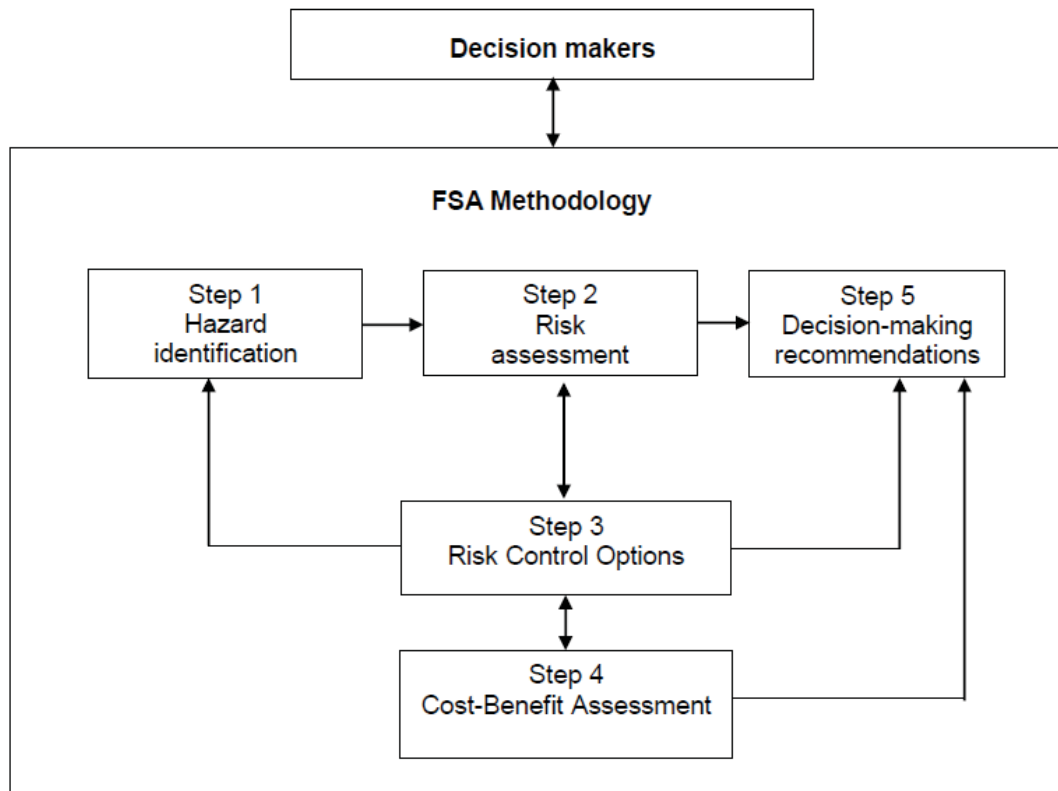

Figure 3: Flow Chart of the FSA Methodology (source: /1/)

## STEP 1 – HAZARD IDENTIFICATION

### Objective and approach

During the first study by tkMS and OWI /2/ it was identified that the differences between fuel properties which are relevant for the formation of explosive mixtures and ignition at ambient conditions, for conventional and LFPD are small. To prove those findings in this document a Hazard Identification (HazId) is used to identify relevant scenarios where potential differences could lead to additional hazards. The main risk contributors resulting from the HazId are investigated in detail in step 2 risk analysis focusing on dependencies from the flashpoint of the diesel fuel.

The HazId is conducted as a moderated expert session taking place on 18<sup>th</sup> of January 2018. The list of experts including a brief characterisation of their expertise is summarised in Annex A “Background of participating experts”. The Failure Mode, Effects and Criticality Analysis (FMECA) technique acc. IEC 60812 /6/ is used to analyse the functions and systems of the generic diesel fuel system model using the reference diesel fuels as defined in chapter 4.

Nature of the FMECA is that each item of the system under review is identified at a required level of analysis. The effects of item failure at that level and at higher levels are analysed during relevant operational modes to determine their severity on the system as a whole. Any compensating or mitigating provisions already present in the SOLAS compliant system are taken into account when discussing effects of failure modes. Considered are items which are active in the corresponding operational mode “normal operation“, “bunkering“, “maintenance and repair“ and for further „external events“.

Severity and frequencies of failures are determined by means of expert judgement during the expert workshop using the rating scales as defined by the FSA guidelines /1/. The experts discussed their estimations in the group and agreed on frequency and severity indices (FI and SI) values. Subsequently, HazId result tables are distributed to all participants to allow for reviewing and commenting.

Finally, the identified hazards and their associated scenarios are ranked in order to prioritize them and to identify scenarios characterising the risk for further consideration in the risk analysis. For ranking the risk index (RI) is used which is the sum of severity index SI and frequency index FI.

### Results

Over all 55 scenarios are identified in the HazId workshop. 17 scenarios are found to be comparable to other identified scenarios, therefore they are combined. The remaining 38 scenarios are ranked against their risk indices.

Based on the results of the first study regarding the small differences in the formation of explosive mixtures and ignition of conventional and LFPD no additional hazards to the operation of conventional diesel fuel system are identified by the HazId. For this reason, no difference in the risk index for the conventional and LFPD system are constituted. The expert group decided to focus on relevant failure scenarios of the operation of conventional diesel fuel systems and to further investigate them in step 2 risk analysis.

In the following the six scenarios with the highest risk indices (RI = 8 and RI = 7) are briefly described:

1. Heat exchanger for cooling of return fuel line: Leakage into the engine room, flammable atmosphere and ignition possible; Normal operation: Failure-No. 30; RI=8;
2. Pumps of transfer system (located in engine room): Leakage into the engine room; flammable atmosphere and ignition possible; Normal operation: Failure-Nr. 15; RI=7;
3. Fuel pumps (located in engine room): Leakage into the engine room; flammable atmosphere and ignition possible; Normal operation: Failure-No. 25; RI=7;
4. Booster pumps: Leakage into the engine room; flammable atmosphere and ignition possible; Normal operation: Failure-No. 26; RI=7;
5. Injection system: Leakage into the engine room; flammable atmosphere and ignition possible; Normal operation: Failure-No. 27; RI=7;
6. Fuel filter: Leakage into the engine room; flammable atmosphere and ignition possible; Normal operation: Failure-No. 29; RI=7.

By analysing these high-rated scenarios and further scenarios identified during the HazId the following main risk contributors are identified:

1. Diesel fuel leakages in various locations of the fuel system
2. Formation / release of ignitable vapour mixtures
3. Ignitable atmosphere inside fuel tanks
4. Increased heat ingress into diesel fuel systems

During the HazId workshop an additional list of fuel specific items were derived from the failure scenarios which could lead to additional risks when using LFPD as marine fuel. This task list is serving as baseline for detailed investigation of the risk-related differences of the fuels in the following step 2 risk assessment (Table 2):

**Table 2: Task list derived from relevant HazId scenarios**

	Action List
<b>1</b>	Fuel specifications
<b>2</b>	Influence of ambient temperature on evaporation rate of diesel with different flashpoints
<b>3</b>	Occurrence of ignitable diesel vapor / air mixture depending on the flashpoint
<b>4</b>	Mixing behavior of different diesel fuels with water (e.g. density, evaporation rate)
<b>5</b>	Potential amount of diesel vapor released from "breathing tank"
<b>6</b>	Self ignition temperature depending on flashpoint and influence on probability of ignition
<b>7</b>	Likelihood of deflagration inside an ventilated room
<b>8</b>	Evaporation rate on different surfaces (water / steel)
<b>9</b>	Conditions inside the tank system (temp., tank head mixture)
<b>10</b>	Relations between ignition energy, mixing behavior with water and radiation heat

## STEP 2 – RISK ASSESSMENT

### Objective and approach

The purpose of the risk assessment is a detailed investigation of the causes, initiating events and consequences of the relevant scenarios identified during the HazId and the evaluation of the risk. For this scenarios selected on basis of the HazId are used focusing potential differences in the evaporation and ignition behaviour of the diesel fuel systems under review.

In the first part of the risk assessment experimental investigations are performed on the behaviour of the two reference diesel fuels with different flashpoints. A detailed investigation plan was derived from the results of the HazId to study the evaporation and ignition behaviour under different conditions. With regards to the HazId scenarios the focus of the laboratory investigations is the determination of the evaporation rate, ignition on hot surfaces and self-ignition considering diesel pools, sprays or wetting of hot surfaces.

In the second part, numerical investigations are performed to transfer the experimental results to relevant failure scenarios of the HazId. Focus of these investigations are potential ignitable atmospheres in the settle tank and the engine room.

For the engine room CFD simulation two scenarios from the HazId were considered:

1. Diesel fuel leakage out of the fuel pumps resulting in a fuel pool below the pumps (cp. Failure scenarios No. 25, 26: Leakage from fuel pumps, booster pumps)
2. Diesel fuel leakage between both engines resulting in a fuel pool between the engines (cp. Failure scenario No. 27: Leakage from injection systems)

Finally, an event sequence analysis is performed to verify the consequences of the scenarios and to study potential differences in the consequences based on experimental data.

### Results from experimental investigations

In this sub-task of the study, diesel fuels with a flashpoint of 60°C and a diesel fuel with a flashpoint of 52°C were characterized for the formation and ignition of explosive atmospheres. The results are summarized in the following Table 3:



**Table 3 - Results from experimental investigations**

No	Method	variable Parameter	FP 60°C	FP 52°C	FP 43°C
1	TGA	test temperatures: 20°C, 40°C, 60°C	20°C, 40°C 60°C	20°C, 40°C 60°C	20°C, 40°C 60°C
2	SIMDEST	none (DIN EN ISO 3924)	done	done	done
3	Flashpoint	none (EN ISO 2719)	60°C	52°C	43°C
4	Autoignition temp.	none (DIN 51794)	289°C	268°C	280°C
5	Single-Droplet evaporator	Temperature	320°C	318°C	324°C
6	Spray ignition	Temperature	up to 450°C	up to 450°C	up to 450°C
7	Poolfire	None	Done	done	done
8	Fuel Specification	None	Done	done	done

The experimental investigation showed only slight differences between both diesel fuels for e.g. the determination of ignition temperatures of tests no. 4 and 5 (compare Table 3). Therefore, and with the intention of increasing the visibility of the effect of flashpoint on characteristic properties the group of reference diesel is enlarged by a third diesel-like fuel with FP 43°C. In all used methods, no significant difference due to the lower flashpoint was observed. Only the thermogravimetric analytic (TGA) showed a slight trend to higher initial evaporation rates in low flashpoint fuels at 60°C test temperature. Referring to the measuring accuracy of the standardized procedures no difference in the ignition behaviour of the different fuels can be found.

### Results of settle tank atmosphere simulations

A two-dimensional simulation of the settle tank atmosphere during filling and discharging of the tank is performed considering both reference diesel fuels (FP 60°C and 52°C), and focusing on the volume fraction of fuel-vapour in the tank atmosphere. By this parameter the ignitability of the tank atmosphere is characterized. Both, transient and stationary simulations are conducted.

For the tank model (Figure 4) a volume of 100 m<sup>3</sup> with 8 m height, 4 m length and 3.125 m width was used. The minimum fuel level is 20% and the maximum is 85%, i.e. the minimum filling height is 1.6 m and the maximum filling height is 6.8 m. The filling from minimum to maximum is assumed to last 4 h and discharge 20 h. The boundary conditions are shown in Figure 4.

For the simulation a homogeneous fuel temperature is assumed inside the tank so that the interface temperature is equal to the bulk fuel temperature. The fuel is in contact with the hot 45°C engine wall and the 32°C cold wall. Additionally, a 32°C fuel source from the main tank is considered during filling.

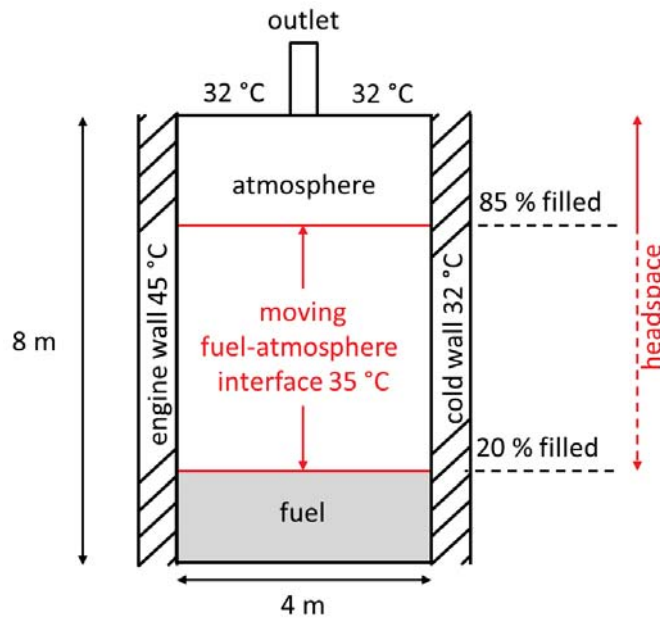
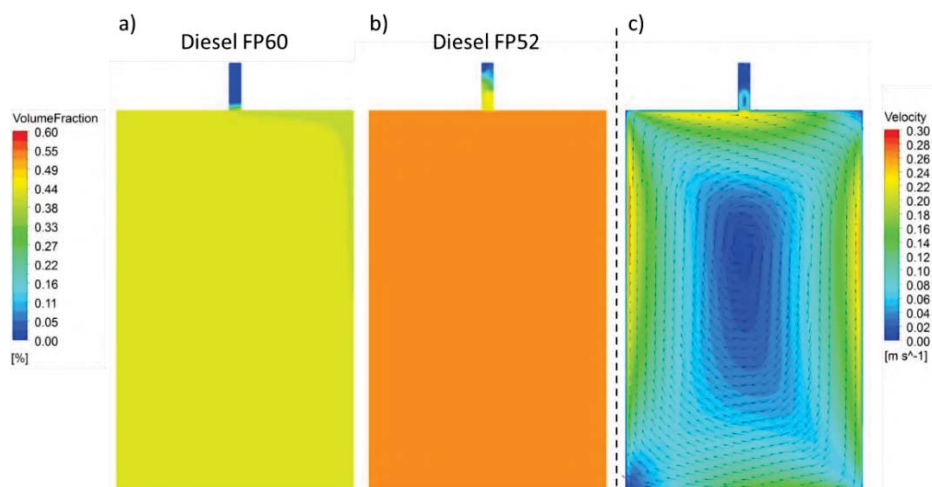

**Figure 4 - Geometry of settle tank model**

The evaporation rates for the different diesel fuels are determined by means of the TGA (Thermo Gravimetric Analysis) performed by the OWI.

The transient simulation with diesel FP 60°C shows that during the filling phase the whole atmosphere is homogeneously filled with fuel vapour with a constant equilibrium volume fraction of 0.412% at  $T = 35^{\circ}\text{C}$ . The reason for the homogeneity is the difference between the different walls of the tank, i.e. top and side have different temperature which leads to a large vortex flow (see Figure 5c) inside the tank atmosphere. This vortex flow causes a well-mixed atmosphere. During the subsequent draining phase the volume fraction does not change any more and stays at its equilibrium value. The final state after one filling-draining cycle is shown in Figure 5a for FP 60°C and in 5b for FP 52°C.

The results of the settle tank atmosphere simulation have shown, that – even under the given stringent conditions- the atmosphere is not ignitable for both diesel fuels with a FP of 52°C and 60°C at any time (cp. Figure 5a tank atmosphere for FP 60°C in yellow, concentration below 0.49 and Figure 5b tank atmosphere for FP 52°C in orange, concentration below 0.55; both are below the LEL of approximately 0,6 %). Only slight differences in the composition of the atmosphere are calculated, from which no difference in the behaviour acc. to the flashpoint can be concluded.



**Figure 5: Simulation results of the settle tank after one cycle or of stationary calculation, a) volume fraction of fuel vapour FP 60°C, b) volume fraction of fuel vapour FP 52°C, c) velocities in the tank**

## Results of engine room simulations

The aim of the engine room simulation is to determine the differences in the evaporation behaviour of the two reference diesel fuels in case of a fuel leakage in an engine room. Therefore, Computational Fluid Dynamics simulations (CFD) of the engine room are performed. Results of the calculations are the spreading of fuel vapour under various boundary conditions (ventilation rate, temperatures) and for diesel fuels with different flashpoints (FP). Arising explosive atmospheres due to leakage are investigated for:

1. fuel leakage out of the fuel pumps resulting in a fuel pool below the pumps (cp. Failure scenarios No. 25, 26: Leakage from fuel pumps, booster pumps);
2. fuel leakage between both engines resulting in a fuel pool between the engines (cp. Failure scenario No. 27: Leakage from injection systems)

For both scenarios in item 1 and 2, a diesel pool in the engine room resulting from the leakage was assumed. For item 1 a pool of 1 m<sup>2</sup> is considered and for item 2 a 10 m<sup>2</sup> diesel pool is considered. For scenario 2 an additional scenario with a diesel spray is simulated. Baseline for the simulation are the evaporation rates as determined by the TGA tests in chapter 7.2.

The simulation of case 1 with a 1m<sup>2</sup> diesel pool showed no differences between the evaporation behaviour of the both fuels. In both cases no ignitable mixtures are formed.

With increasing fuel pool size the fuel vapour concentrations the engine room raise. The comparison of fuel vapour distribution and isosurfaces for case 2, engine room with 10 m<sup>2</sup> fuel pool between engines, are shown in Figure 6 and Figure 7.

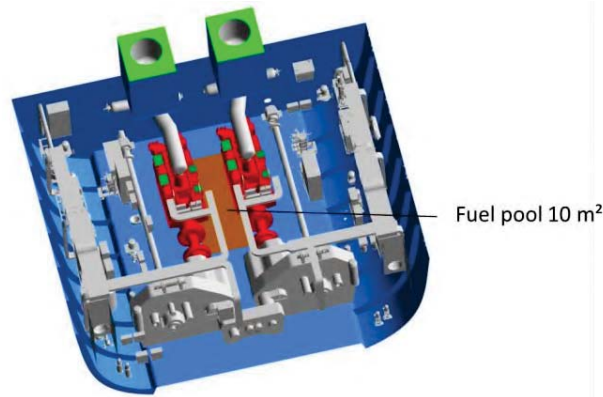

**Figure 6 - Position of fuel pools caused by leakage, scenario: 10 m<sup>2</sup> between engines**

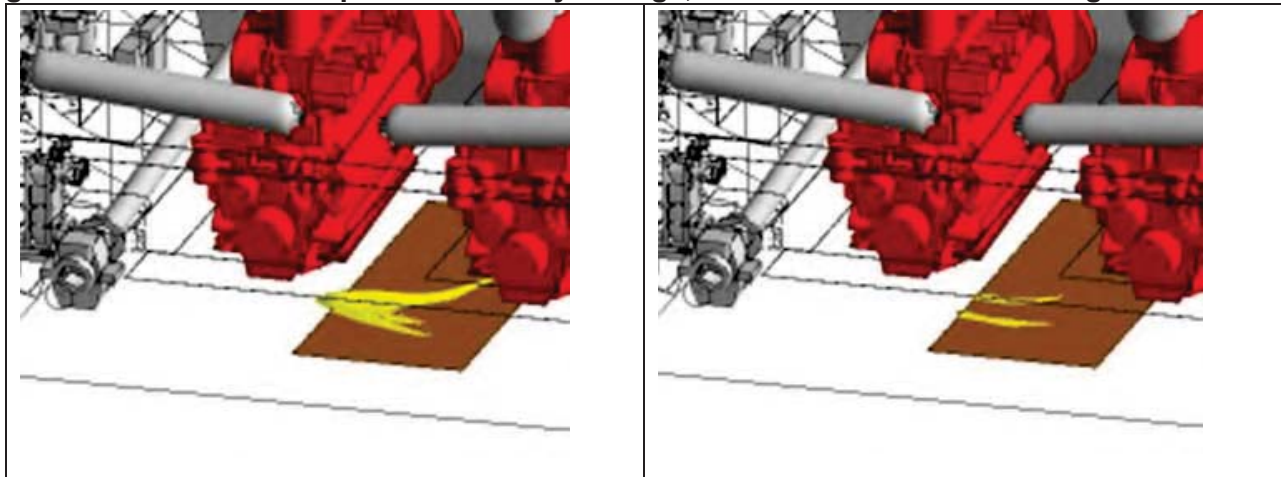

**Figure 7: Isosurface fuel vapour concentration 100% LEL, 10 m<sup>2</sup> fuel pool between engines (case 2), for diesel FP = 52°C (left) and diesel FP = 60°C (right)**

In this case 2 the differences between both fuels with respect to the evaporation behaviour are also small. The increased total amount of evaporated (10 m<sup>2</sup>) fuel leads to small areas of explosive atmosphere, see

Figure 7. The volume of these “plumes” is 8.5 l for diesel FP 60°C and, respectively, 44.2 l for FP 52°C. Due to the generally low rate of flame propagation an ignition will cause no explosion. Instead, for both fuels a deflagration is expected, in case 2 leading to a small (negligible) pressure increase in the engine room. The consequences of these deflagration are locally limited due to the small amount of ignitable mixtures in comparison to the engine room volume of about 870 m<sup>3</sup>.

The results of transient simulations are showing, that the dispersion of fuel vapour cloud in case 2 is completed in 1 – 2 minutes with negligible time differences between both reference diesel, and then remain constant until all fuel is evaporated.

Further, the consequences of a small leakage causing a diesel spray is investigated. This simulation of the diesel spray between both engines showed, that no ignitable atmosphere will be generated at all. This was confirmed by a diesel spray test program, where the fuel spray was intended to be ignited only in contact with a hot surface. Within these tests, no ignition was generated until surface temperatures of 450°C (see Table 3).

The engine room simulation showed slight difference of the evaporation behaviour of the diesel fuels for the worst case analysis having a very large leakage in the engine room. Considering the dimensions of the engine room the differences in the volume mixtures and dispersion time of the LPFD and the diesel fuel with a FP of 60°C are negligible.

### Results of event sequence analysis

For a further analysis the event sequences of the main risk scenarios risk models were developed. Objective is the comparison of the HazId and experimental investigation results to highlight single branches where potential difference between the fuels with different flashpoint could be identified and further risk control measures are necessary.

Risk models were developed in form of Event Trees (ET). An illustrative example is shown in **Error! Reference source not found.** for leakage scenarios. This tree can be drawn for both small and large leakages and different fuel conditions, i.e. liquid fuel, fuel in form of droplets or spray. Immediate ignition on hot surfaces is assessed by the properties resulting from tests no. 4, 5, and 6, see **Error! Reference source not found.** The occurrence of ignitable atmosphere is predicted by CFD simulations using the determined evaporation rates (test no. 1). If the leakages of the low flashpoint diesel fuel will lead to a higher risk than those caused by conventional diesel, suitable actions are to be taken.

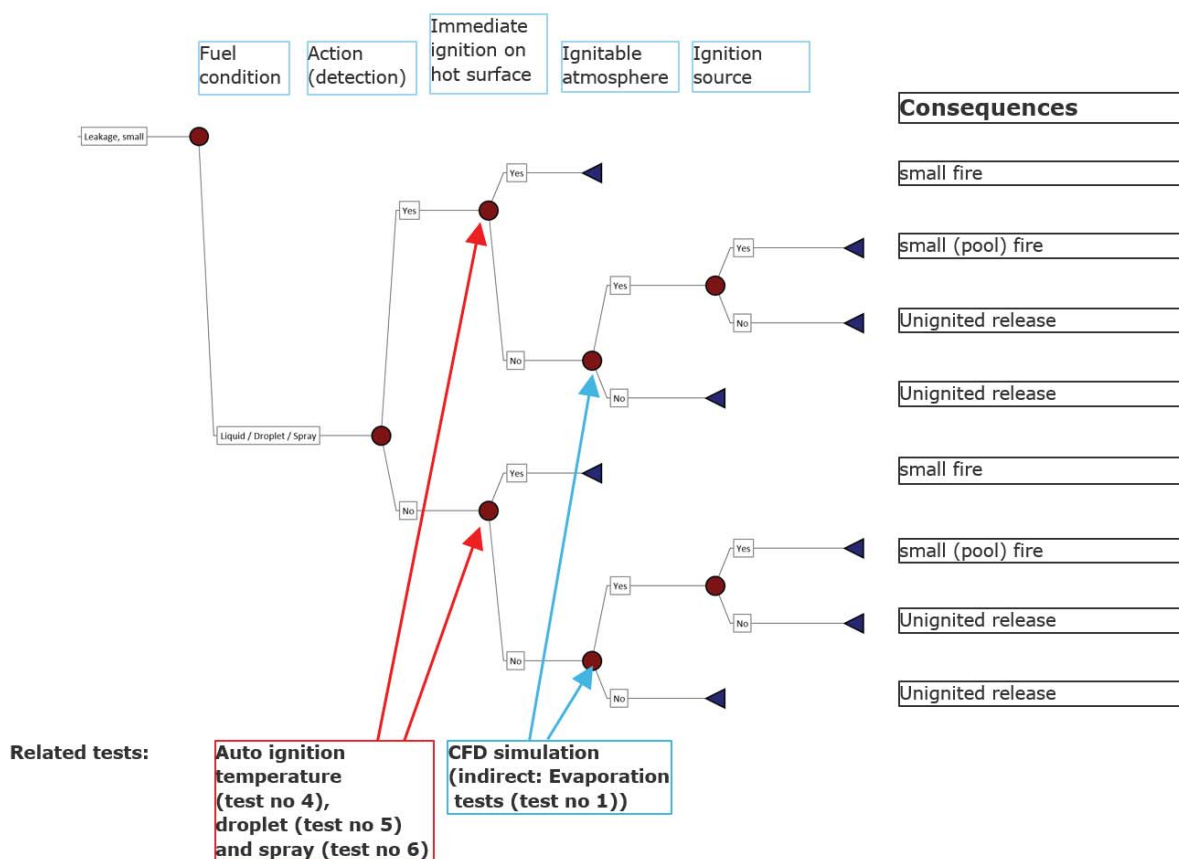

Figure 8: Event sequences for leakage scenarios

The experimental investigations showed no differences in the ignition behaviour of both fuels. For the evaporation behaviour only slight differences were identified during CFD simulation. Based on this results no differences in risk is determined.

### **Fire inside a tank**

The existence of flammable atmosphere inside a tank has been analysed by numerical calculations and CFD simulations. The CFD analyses in chapter 7.3 revealed that no flammable atmosphere inside the tank is to be expected for both FP 60°C and LFPD, even if quite conservative boundary conditions are applied, e.g. high tank wall and fuel temperatures. The difference between both diesel fuels are negligible wherefore no event sequence was illustrated.

### **Release of flammable atmosphere**

The existence and potential release of flammable atmosphere has been analysed by numerical calculations and CFD simulations. As stated in chapter 7.3 no ignitable atmosphere inside the tank was predicted by CFD calculations. Therefore, it is concluded that no ignitable atmosphere will be released via the tank venting system. The difference between both diesel fuels are negligible wherefore no event sequence was illustrated.

### **Increased heat ingress**

Numerical analyses showed, that an increasing fuel temperature in the tank will lead to an ignitable atmosphere in the tank head space. This applies for both fuels. A slight difference for the minimum temperature where the ignitable atmosphere appears but the difference in the temperature range is negligible. For that reason, no event sequence was illustrated.

### **Summary of risk assessment results**

The analytical part of the study showed for the diesel fuel with a flashpoint of 60°C and the diesel-like fuel with a flashpoint of 52°C only slight difference due to the lower flashpoint was observed. With the intention of increasing the visibility of the effect of flashpoint on characteristic properties, the group of reference diesel is enlarged by a third diesel-like fuel with FP 43°C. Even with this fuel, in all used experimental methods, no significant difference due to the lower flashpoint was observed. Only the thermogravimetric analytic (TGA) showed a slight trend to higher mass loss in low flashpoint fuels at 60°C. Considering the measuring accuracy of the standardized procedures no difference in the ignition behaviour of the different fuels can be found.

The simulation of the settle tank atmosphere showed also no significant difference in the concentration of the atmosphere of a diesel fuel with FP 52°C to that of a diesel fuel with FP 60°C.

The engine room simulation showed slight difference of the evaporation behaviour of the diesel fuels only in case of a worst case analysis assuming a very large leakage in the engine room of 10 m<sup>2</sup>. Taking further into account the dimensions of the engine room the differences in the volume mixtures and dispersion time of the LFPD and diesel fuel with FP 60°C are negligible.

### Step 3: Risk Control Options

The risk assessment showed no additional risks due to the use of low-flashpoint diesel compared to the use of conventional diesel fuel. Slight differences in the evaporation behaviour were identified by the TGA experiments. Only for worst case scenarios with significant amount of spills small differences in the amount of ignitable mixtures are observed. Even though, to in order to address uncertainties inherent in the analyses, i.e. avoid potential effects due to uncertainties in the evaporation rates, it is conservatively suggested to consider the following risk control measures:

1. Bilge systems installed in areas with LFPD fuel installations shall be segregated from other bilge systems.
2. Other tanks containing LFPD-fuel, e.g. drain tanks, shall not be located within machinery spaces or within accommodation spaces.

### Step 4: Cost-benefit assessment

Typically, cost-benefit assessment is used to evaluate the benefit of RCOs with respect to the cost criterion proposed in FSA guidelines<sup>1</sup>. Basis of this study is the evaluation of risk by means of SOLAS compliant design, i.e. safety equivalency. Therefore, application of ALARP principle including cost-benefit assessment is regarded not necessary. Anyway, an indication of potential cost for the identified RCO's is performed based on yard estimations.

The introduction of additional protect temperature measurement, stop valves and welded pipe joints items 2 to 4 in section 7 leading to negligible additional costs (few 1,000 USD).

The segregation of the bilge system of the LFPD fuel from other bilge systems (chapter 8; item 1) are already done for diesel systems due to environmental reasons and hence do not cause additional costs.

The relocation of tanks containing LFPD-fuel (chapter 8; item 2) leading to additional pipe length, fittings and bulkhead penetrations leading to additional costs of few 10,000 USD (depending on distance) which are negligible in comparison to the total costs of the fuel system.

It is expected that additional costs for the proposed measures are negligible for Newbuildings with LFPD-fuel systems. For retrofits, cost indications cannot be estimated as they are depending on the individual design.

---

<sup>1</sup> Respectively values specified in recent investigations GOALDS and EMSA III using a thresholds of 7.4 million USD per avoided fatality.

## Step 5: Recommendations

The study shows only differences in risk between conventional and low-flashpoint diesel, and only for worst case scenarios with big amounts of diesel fuel in the engine room. Even though, some RCO's are considered to mitigated potential effects from these. In terms of risks no further RCO's are necessary for the safe operation of the low-flashpoint diesel fuel systems.

However, as discussed in section 0 current IMO instruments allow the usage of diesel with a flashpoint below 60°C for special application and when complying with related regulations. Therefore, to avoid potential inconsistencies in the IMO instruments it is recommended to consider the measures as defined in SOLAS Chapter II-2 Rule 4 2.1.1 as well for general applications of low-flashpoint diesel fuel systems. The following SOLAS requirements are to be considered:

1. fuel oil tanks except those arranged in double bottom compartments shall be located outside of machinery spaces of category A;
2. provisions for the measurement of oil temperature are provided on the suction pipe of the oil fuel pump;
3. stop valves and/or cocks are provided on the inlet side and outlet side of the oil fuel strainers; and
4. pipe joints of welded construction or of circular cone type or spherical type union joint are applied as much as possible;

In addition, It is recommended to consider the proposed Risk Control Measures as listed in chapter 8 "Step 3: Risk Control Options" for the further rule making process for low-flashpoint diesel as marine fuel.



## APPENDIX A – Background of participating experts

1. Thorsten Tüxen (Caterpillar)

**Section Supervisor Engine Fuel Systems & SCR**

>5 Years: Development and supervision of gas admission valves & gas valve units for medium speed engines meeting requirements of IGC & IGF codes

>5 Years: Development and supervision of fuel injection systems capable for MDO, HFO and Crude Oil for medium speed engines for the marine market

>10 Years: Development of system & components for gas operation

2. Finn Vogler (Caterpillar)

**Engine system design and operation**

Finn Vogler was working for Germanischer Lloyd since 2005 in the research and development department with the topics Gas as Fuel, Fuel Cells, Rule Development and Risk Analysis. In this respect, he was involved in the IGF-Code development and all JIP and development projects of Germanischer Lloyd with regard to gas as fuel.

Since 2012 Finn Vogler is working with Caterpillar Gas System Technology Team with the topic on DF engine conversions and the management and supply of gas systems to Caterpillar customers including supplier coordination.

Mr. Vogler studied Naval Architecture and finished studies as DIPL. ING. in 2005.

3. Dr. Rainer Hamann (DNV GL)

**Formal safety assessment**

Joined DNV GL in 1995. Strong background in various topics of mechanics as well as material technology. Since 2005 responsible for risk assessment and development of related methods/processes and participated in several FSAs (containership, general cargo ship, GOALDS, EMSA III). For more than ten years advisor of German Ministry of Transport on IMO topics FSA and Goal-Based Standards including the representation at IMO meetings (MSC, SSE/DE).

Rainer Hamann finished his studies at Technical University Braunschweig in 1989 as mechanical Engineer and his doctor degree in 1995 at Technical University Hamburg-Harburg.

4. Stephan Eylmann (DNV GL)

**Risk Assessment**

Stephan Eylmann joined DNV GL in 2008 as senior project engineer, working initially in the field of structural analysis, later in the field of risk assessment. He holds a Dipl.-Ing. degree in shipbuilding from the Technical University Hamburg-Harburg.

5. Lars Langfeldt (DNV GL)

**Risk Assessment**

Lars Langfeldt joined DNV GL Maritime as project engineer for the assessment of alternative fuels and energy converters in year 2008. His areas of expertise are safety analysis with focus on the assessment of low-flashpoint fuel installations.

Mr. Langfeldt finished his studies in mechanical engineering at the University of Applied Sciences in Hamburg in 2007 and his Master studies in electrical engineering in 2018 at the Fernuniversität in Hagen.

6. Benjamin Scholz (DNV GL)

**Safety and regulatory requirements of LFP fuel installations**

Benjamin Scholz is working as ship type expert liquefied gas carrier in the section Machinery Systems & Marine Products at DNV GL, Hamburg. As project manager he is responsible for different client and research projects with the focus gas as ship fuel and liquefied gas carrier. Contributing to the development of the International Code of Safety for Ships Using Gases or Other Low-Flashpoint Fuels (IGF Code) is part of his area of responsibility. He joined DNV GL in 2008 after studying mechanical engineering at the University of Rostock.

7. Peter von Allwörden (DNV GL)

**Tanker Expert**

Joined DNV GL in 1999.

Master Mariner, Marine Engineer, Engineer for Electrical Engineering.

Since 2002 responsible for Oil-, Gas- and Chemical Tanker cargo and ship systems.

Frequent risk assessments related to the above.

8. Dr. Christoph Rohbogner MAN

**Specialist Marine Fuels**

Christoph Rohbogner is a PhD Chemist. He joined MAN Diesel & Turbo in 2014 as head of department, leading the Chemical Laboratory. His expertises are: engine fluids, especially fuels, lubricants and coolants.

He is member of CIMAC WG 7 (Fuels) WG8 (Marine Lubricants), DIN FAM NA 062-06-34 AA (Heating Oils and Marine Fuels) and ISO ISO/TC 28/SC 4/WG 6 (Classification and specification of marine fuels).

9. Dirk Blomke Minimax

**Fire safety system design**

Manager Marine Division

10. Christian Prinz MTU

**Engine system design and operation**

Christian Prinz is working as a sales manager at MTU Friedrichshafen GmbH, Hamburg office since 2013. He is responsible for sales of marine engines for commercial vessel and authority vessels in Germany.

Christian Prinz studied Mechanical Engineering at TU Hamburg-Harburg.

After his studies, he worked at the machinery departments of Flensburger Schiffbau-Gesellschaft and Sietas, with responsibilities for layout and design of the propulsion and energy generating systems.

At both shipyards, he also worked on projects regarding fuel cells and LNG

11. Pawel Bittner OWI

**Numerical Tank Simulation**

Mr. Bittner joined the Calculation and Simulation workgroup at Oel-Waerme-Institut in 2017. The group focus is on numerical analysis of materials and fluid flows in a system, development of mathematical models for model-based control system and transient simulation of dynamic systems. Mr. Bittner finished his studies in materials engineering at RWTH-Aachen in 2015 with a masters degree. Since then he also began a part-time study in mathematics at RWTH-Aachen.

12. David Diarra OWI

***Diesel fuel specifications and properties***

Mr. David Diarra is employed at OWI since 2001. As a senior research engineer his expertises are liquid fuel combustion, atomization and evaporation of fuels, reaction kinetics of ignition and combustion of hydrocarbons. Furthermore, he is experienced in safety analysis (HAZOP) of fuel cell systems including reforming components. Since 2014 he is the managing director of OWI.

13. Sebastian Feldhoff OWI

***Diesel fuel specifications and properties***

Mr. Feldhoff joined OWI Oel-Waerme-Institut gGmbH in 2012 and since 2017 he is the team leader of the workgroup Fuels and Lubricants. The group focuses on properties of liquid fuels and lubricants and their application in technical systems. Within the scope of his Ph.D. thesis Mr. Feldhoff is dealing with the estimation of laminar combustion velocities of liquid fuels. Additionally he is an active member of the ProcessNet working committee "Alternative flüssige und gasförmige Kraft- und Brennstoffe (AA-AKB)" of DECHEMA. Mr. Feldhoff finished his studies of mechanical engineering at the university of Duisburg-Essen in 2010 with a Dipl.-Ing. degree.

14. Melanie Grote OWI

***Engine room simulation***

Mrs. Melanie Grote has a graduate degree in Chemical Engineering from Technical University Dortmund. She has been working at OWI Oel-Waerme-Institut gGmbH since 2001. She is expert in modelling and numerical simulation, especially in Computational Fluid Dynamics (CFD). In past projects she worked on modelling of fuel evaporation. Since 2017 she is team leader of the group High-temperature Technology, which deals with research and development in the fields of innovative evaporation and combustion technology for liquid fuels as well as material technology.

15. Holger Kapahnke tkMS

***Engine room and fuel system design***

Mr. Holger Kapahnke has been working for several years in the design department of ThyssenKrupp Marine Systems. His main field of expertise is the design of engine rooms and the generation of Cad models.

16. Keno Leites tkMS

***Engine room and fuel system design***

Keno Leites has studied mechanical engineering with a focus on ship machinery and energy conversion at the technical university of Hamburg-Harburg. After his studies he worked for 8 years in the project department of Blohm+Voss, with responsibilities for the complete machinery and the electronic systems. From that function he moved to the research and development department and lead projects in the same fields. For the last 10 years he is in charge of projects on alternative energy sources and systems, e.g. LNG, LFPD, fuel cells, HTS and similar.

## APPENDIX B – List of References

- /1/ International Maritime Organization (IMO): Revised Guidelines for Formal Safety Assessment (FSA) for Use in the IMO Rule-Making Process. MSC-MEPC.2/Circ.12/Rev.2, 2018
  - /2/ ThyssenKrupp Marine Systems and the OWI: Safety relevant properties of low flashpoint diesel fuels, information paper CCC 4/INF11, July 2017
  - /3/ International Maritime Organization (IMO): International Convention for the Safety of Life at Sea (SOLAS), 1974, as amended
  - /4/ DIN EN 590: Automotive fuels - Diesel - Requirements and test methods, 2017
  - /5/ ISO 8217: Petroleum products - Fuels (class F) - Specifications of marine fuels, 2017
  - /6/ IEC 60812: Analysis techniques for system reliability - Procedure for failure mode and effects analysis (FMEA), 2006
-

SUB-COMMITTEE ON CARRIAGE OF  
CARGOES AND CONTAINERS  
6th session  
Agenda item 3

CCC 6/INF.X  
8 June 2018  
Original: ENGLISH  
Pre-session public release:

## AMENDMENTS TO THE IGF CODE AND DEVELOPMENT OF GUIDELINES FOR LOW-FLASHPOINT FUELS

### FSA Study on the Use of Low-Flashpoint oil fuels

**Submitted by Austria, Belgium, Bulgaria, Croatia, Cyprus, the Czech Republic, Denmark, Estonia, Finland, France, Germany, Greece, Hungary, Ireland, Italy, Latvia, Lithuania, Luxembourg, Malta, the Netherlands, Poland, Portugal, Romania, Slovakia, Slovenia, Spain, Sweden, the United Kingdom and the European Commission**

#### SUMMARY

*Executive summary:* This document presents the full report of a FSA study on safety related issues for the potential use of low-flashpoint oil fuels

*Strategic Direction, if applicable:* 2

*Output:* 2.3

*Action to be taken:* Paragraph 3

*Related documents:* MSC.391(95); CCC 2/15; SOLAS II-2; CCC 4/3/5, CCC 4/INF.11, CCC 4/12; CCC 5/3/4; CCC 6/3/XX

#### Introduction

1 This document is submitted in view of the discussion on the use of low-flashpoint oil fuels in the context of SOLAS chapter II-2 and the IGF Code (resolution MSC.391(95)). As discussed at MSC 94, MSC 95, MSC 96, MSC 98, CCC 2, CCC 4 and CCC 5, provisions should be made to allow for the use of low-flashpoint diesel.

2 In support of the further debate on the use of low-flashpoint oil fuels on ships to which SOLAS and the IGF Code apply, a study addressing safety related issues for the use of low flashpoint oil fuels, comparing the hazards and risks in the use of low-flashpoint oil fuels to oil fuels with a flashpoint of 60°C and above, is presented in the annex to this document.<sup>1</sup>

**Action requested of the Sub-Committee**

3 The Sub-Committee is invited to note the information provided and take action as appropriate.

\*\*\*

---

---

<sup>1</sup> Due to its size, the full report is not included in this I-item note; it can be found in doc. 9597/19 ADD 2.