



Council of the
European Union

126644/EU XXVII.GP
Eingelangt am 10/01/23

Brussels, 10 January 2023
(OR. en)

5180/23
ADD 5

ENER 13
ENV 17
TRANS 7
ECOFIN 24
RECH 11
CLIMA 8
IND 3
COMPET 15
CONSOM 5

COVER NOTE

From: Secretary-General of the European Commission, signed by Ms Martine DEPREZ, Director

date of receipt: 9 January 2023

To: Ms Thérèse BLANCHET, Secretary-General of the Council of the European Union

No. Cion doc.: SWD(2023) 1 final - PART 5/6

Subject: COMMISSION STAFF WORKING DOCUMENT Accompanying the document REPORT FROM THE COMMISSION TO THE EUROPEAN PARLIAMENT, THE COUNCIL, THE EUROPEAN ECONOMIC AND SOCIAL COMMITTEE AND THE COMMITTEE OF THE REGIONS
JRC technical report on "Assessment of the potential for energy efficiency in electricity generation, transmission and storage"

Delegations will find attached document SWD(2023) 1 final - PART 5/6.

Encl.: SWD(2023) 1 final - PART 5/6



Brussels, 9.1.2023
SWD(2023) 1 final

PART 5/6

COMMISSION STAFF WORKING DOCUMENT

Accompanying the document

**REPORT FROM THE COMMISSION TO THE EUROPEAN PARLIAMENT, THE
COUNCIL, THE EUROPEAN ECONOMIC AND SOCIAL COMMITTEE AND THE
COMMITTEE OF THE REGIONS**

**JRC technical report on "Assessment of the potential for energy efficiency in electricity
generation, transmission and storage"**

{COM(2023) 1 final}

Contents

Abstract.....	1
1 Introduction.....	2
2 Fossil fuels power plants	3
2.1.1 Introduction	3
2.2 Thermodynamics and thermal generation	5
2.2.1 The Rankine cycle	5
2.2.1.1 Coal power plants.....	7
2.2.1.2 Oil power plants	9
2.2.1.3 Gas power plants.....	9
2.2.1.4 The Brayton cycle	9
2.2.2 The Combined cycle.....	11
2.3 Current efficiency of the European thermal power plants	13
2.4 Summary of the thermal plant efficiencies.....	14
3 Storage technologies.....	15
3.1 Introduction	15
3.2 Mechanical energy storage	16
3.2.1 Pumped hydro storage	16
3.2.2 Compressed Air Energy Storage (CAES).....	18
3.2.3 Liquid air energy storage	19
3.2.4 Flywheels	19
3.3 Electrochemical energy storage.....	21
3.3.1 Lead-acid batteries	21
3.3.2 Lithium-ion batteries	22
3.3.3 Flow batteries	22
3.3.4 High temperature batteries	23
3.4 Electrical energy storage.....	24
3.4.1 Supercapacitors	24
3.4.2 Superconducting Magnetic Energy Storage.....	25

3.5	Chemical energy storage.....	25
3.5.1	Power-to-hydrogen.....	25
3.6	Summary of storage efficiencies	26
4	Transmission High Voltage Direct Current systems.....	27
4.1	Introduction	27
4.2	HVDC system structure	29
4.3	Line Commutated Converters (LCC).....	32
4.4	Voltage Source Converters (VSC)	33
4.5	Technical-economic HVAC vs. HVDC comparison	34
4.6	Conclusions on power losses in HVAC and HVDC Transmission Systems	36
5	Conclusions.....	38
	References	39
	List of abbreviations and definitions	43
	List of figures	45
	List of tables	47
	APPENDIX I - Coal	48
	APPENDIX II - Gas	50
	APPENDIX III – Storage	57
	APPENDIX IV – HVDC Technologies	58

4 Transmission High Voltage Direct Current systems

4.1 Introduction

It has been widely documented in the history of the electricity industry that the first commercial electricity generated (by Thomas Alva Edison) was Direct Current (DC) electrical power. The first electricity transmission systems were also in DC. However, DC power at low voltage could not be transmitted over long distances, and that gave rise to high voltage Alternating Current (AC) electrical systems [60], leaving DC applications to very small-scale and particular cases. Nevertheless, with the development of high voltage power electronics, it was possible to transfer DC power once again at high voltages and over long distances for the DC interconnection of power systems, exploiting favourable efficiency of DC transmission. Since the first commercial installation in 1954, several HVDC transmission systems have been installed around the world.

High-voltage direct current (HVDC) is an increasingly important technology for transferring electrical power common also in the European transmission grid [61]. Figure 28 shows the cross-frontier transmission lines operated by European TSOs [62]. HVDC systems are used either for submarine interconnection or for cross-border interconnections, mostly cables. Several further projects are currently under construction. Among those, the second HVDC module (600 MW) of the Italy-Montenegro interconnection project is strictly correlated with the Transbalkan and the Mid Continental East corridors, and therefore will contribute significantly to enable the usage of an increased transmission capacity between Italy and South-East European Countries, especially Romania and Bulgaria. Another one, called ALEGrO, realizes the first interconnection between Belgium (Lixhe) and Germany (Oberzier) as a 100 km HVDC link with a bidirectional rated power of 1.000 MW capacity. ElecLink is, instead, a new FR – UK interconnection cable with 1000 MW capacity through the Channel Tunnel between Sellindge (UK) and Mandarins (FR). Converter stations will be located on Eurotunnel concession at Folkestone and Coquelles. Lastly, the interconnection of Crete to the Mainland System of Greece is already under construction. Crete is the largest electrically non-interconnected island system in Greece, representing a particular case, due to large size, rapid growth, remote location and large RES potential. The project aims at increasing security of supply and improve stability issues of the island. It is expected to contribute to the reduction of the operation of oil-fired units that currently supply the island and in the long run to allow their progressive decommissioning, thus contributing to the reduction of production variable costs and greenhouse gas emissions. This interconnection will be implemented in two phases. In Phase I Crete will be connected to Peloponnese with a 150 kV AC double circuit submarine cable interconnector of 2x200 MVA nominal transfer capacity. In Phase, II Crete will be connected to Attica with a bipolar submarine HVDC-VSC link of 2x500 MW capacity transfer.

There are further projects ongoing on offshore DC transmission connections. Most of the projects are either in North or Baltic sea. On the one hand, the NordLink is a new HVDC connection between Southern Norway and Northern Germany and consists in a 514 km subsea cable with a capacity of 1400 MW. On the other hand, North Sea Link is a 720 km long subsea interconnector between Norway and Great Britain which is planned to be commissioned in 2021. When realised, it will be the world longest subsea Interconnector. The main driver for the project is to integrate the hydro-based Norwegian system with the thermal, nuclear and wind-based British system. The interconnector will improve security of supply both in Norway in dry years and in Great Britain in periods with negative power balance (low wind, high demand etc.). In addition, the interconnector will be favourable for the European market integration, whilst also facilitating renewable energy in preparation for a power system with lower CO₂-emissions. The so-called Viking DKW-GB is, instead, a 2x700 MW HVDC subsea link across the North Seas which relies on new substations on both sides, Bicker Fen (GB) and Revsing (DK). The last project is related to the Baltic states synchronization with continental Europe. The project covers a lot of new investments for internal grid reinforcements - new 330 kV and 400 kV AC lines, voltage stabiliser units, synchronous compensators, upgrades of PSS in power stations, internal 110 kV network reinforcement required for synchronization and separation of 110 kV Baltic grid from IPS/UPS system. As part of the project, after the synchronization, a new HVDC connection will be established between LT-PL allowing for a commercial exchange of the Baltic States with Continental Europe in the amount of 700 MW.

Many other projects are still in the earliest or very early stages of implementation: 10 projects are in the authorization phase, 2 are planned but not yet authorized and 18 are being studied.

Figure 28: Cross-frontier transmission lines operated by European TSOs [62].

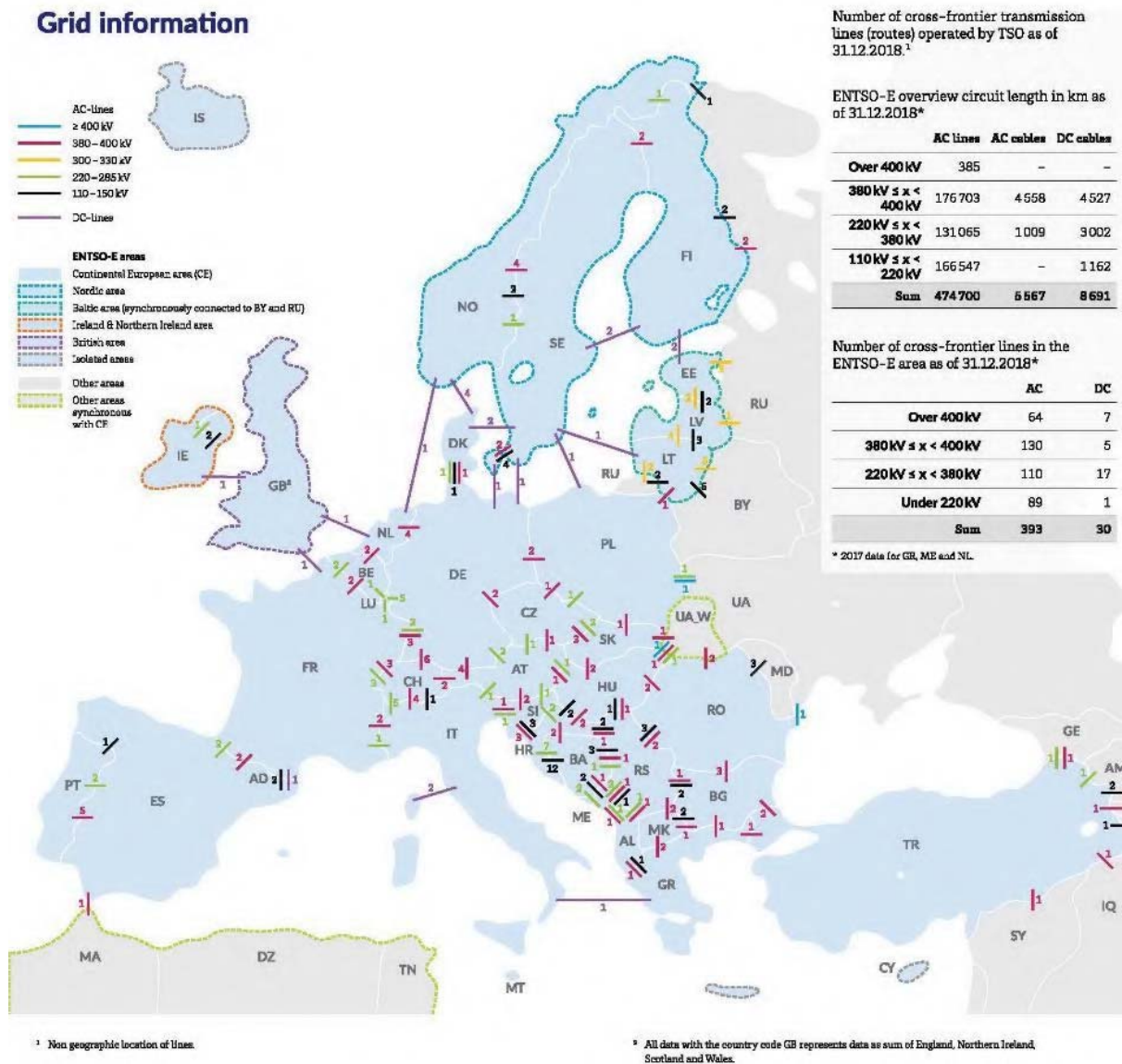

New HVDC links play a key role in future development plans for the European transmission grid and internal market. The use of the advanced functionalities of these HVDC links in system operations is essential for the secure and efficient operation of the grid. ENTSO-E, the European Network of Transmission System Operators which represents 43 electricity transmission system operators (TSOs) from 36 countries across Europe, recognizes the importance of the functionalities and ancillary services that can be provided by HVDC links. Moreover, the HVDC technology makes it possible to benefit from the efficiency that DC transmission can readily provide. The use of the functionalities of the HVDC links in system operations contributes to meeting current and future challenges, such as decarbonisation and large-scale integration of Renewable Energy Sources (RES) which are largely connected via Power Electronics (PE). Such technologies result in the decommissioning of classic rotating power plants and the disappearance of the physical characteristics the power system was built on. In addition, the HVDC technology may support the realisation of an integrated European energy market and the sharing of ancillary services between countries and synchronous areas. Today, HVDC links are typically used for long-distance bulk power interconnections, using both overhead lines and submarine cables, in some cases for connecting two asynchronous, non-embedded AC systems, and for the subsea interconnection of large offshore wind farms. They can also be designed to provide ancillary services to AC systems, such as frequency control, emergency controls, fast power reversal, etc.

The main advantages of DC over AC are the elimination of the reactive power requirement, lower operational losses in the DC link and the possibility to easily control real power flows in a meshed AC system. There are also disadvantages for HVDC systems: for voltage transformation, transformers cannot be used; circuit breakers and protections are still problematic, especially in case of meshed DC systems; the most important drawback is the high costs that, independent of the distance of transmission, are needed to provide AC/DC conversion at both ends of the DC link.

4.2 HVDC system structure

A generic HVDC system structure overview is reported in Figure 29. In the first HVDC station, the converter transformer changes the AC voltages to the required level. The converter station takes the electric power from the three-phase AC network and rectifies it into DC; the power is then transmitted through overhead lines or cables. At the receiving end of the DC line, an inverter converts the DC voltage back to AC, and a transformer connects the link to the local power system. This technology is suitable for transmitting power in the range 100 MW -10 GW.

Figure 29: HVDC system structure [63].

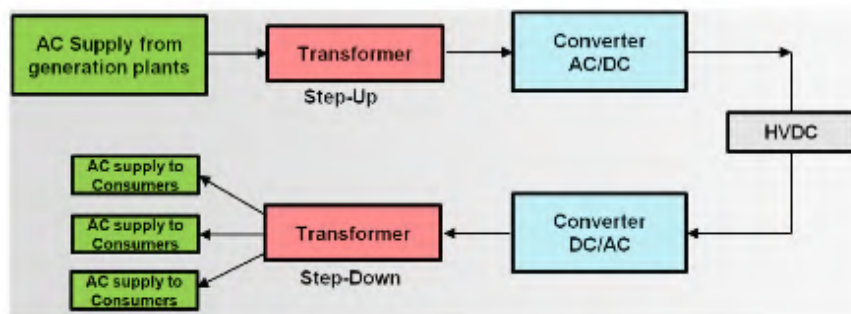

As shown in Figure 30 the backbone of any HVDC system is the converter station which converts AC voltage to adequate DC transmission voltage level (AC/DC converter) at one end, and converts the DC voltage back to adequate AC grid interfacing voltage level (DC/ AC converter) at the other end. The notions of sending and receiving end are often used interchangeably depending on the power flow direction. The converters are protected by AC circuit breakers while the voltage is adjusted to the required level by means of transformers [64].

Short-circuit protection of HVDC transmission conductors requires DC circuit breakers (DCCB). Interrupting a DC current represents one of the principal technical challenge as, in contrast to AC, there is no natural zero crossing which provides an opportunity for current flow to be broken.

Figure 30: Generic HVDC transmission system layout with component-based description. DCCBs are not typically implemented in point-to-point links and are displayed to illustrate their principal of operation [65].

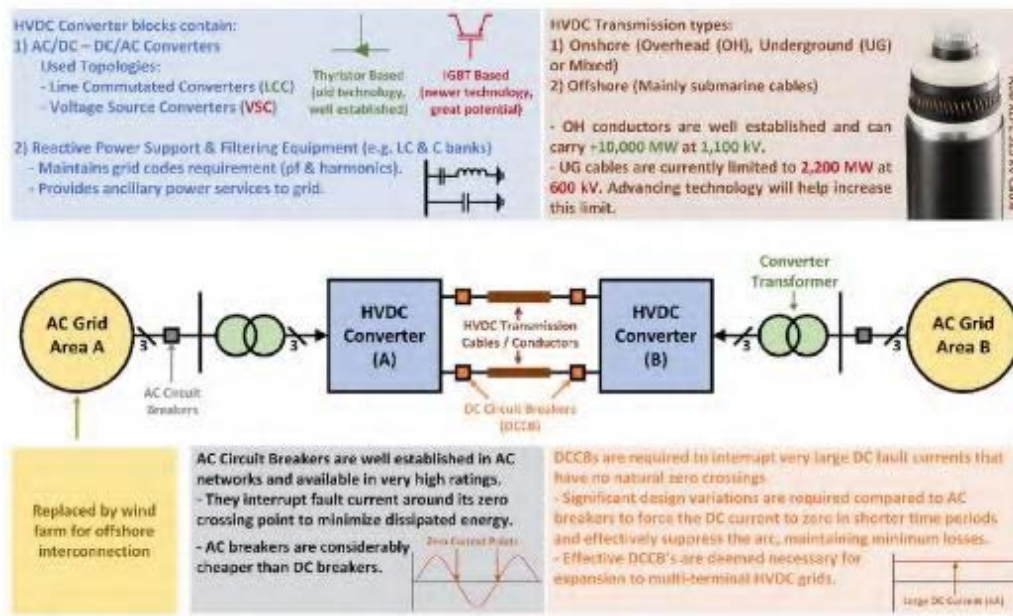

Two main converter types are being used in HVDC links:

- Line Commutated Converters (LCCs), which employ line-commutated thyristor valves;
- Voltage Source Converters (VSCs) which rely on Insulated Gate Bipolar Transistors (IGBTs).

Additionally, reactive power banks and filtering equipment have to be installed to maintain grid codes requirement in terms of power factor and harmonics as well as to provide ancillary services to the AC grids.

Both LCC and VSC links can be connected using different AC network configurations. The DC network topology or configuration selection is mainly influenced by the required level of reliability, rating, cost-effectiveness and compliance with policies and regulations [66]. Commonly used topologies of HVDC transmission systems are DC monopoles and bipolar system, while DC tripolar system are rarely implemented and mostly based on design variations of the other common configurations [67]. Appendix IV gives out an overview of the comparison between the two different HVDC technologies in terms of power transmission .

A particular case is Back-to-Back connections, primarily used to link unsynchronized neighbouring AC networks. With a back-to-back HVDC link, two independent neighbouring transmission systems with incompatible electrical frequencies, with exceeding short-circuit power levels or with different operating philosophies are connected, putting converters in the same converter station.

Figure 31 reports the common HVDC transmission configurations. In the monopolar configuration, the power transfer between the two converter stations makes use of a single DC pole rated for full high-voltage DC capacity. The return circuit can be a low voltage return path (asymmetrical monopole), which may be realized using an earth electrode at each station, or a low-voltage metallic return link [68]. Earth electrodes require special design considerations to accommodate the fully rated DC current and are typically placed away from the converter stations and connected using electrode lines [69][70]. This option is cost effective and avoids the use of return cable/conductor extending over the whole link distance. Yet, several existing regulations/policies restrict the use of earth electrodes in many HVDC projects due to their negative environmental impact, especially in case of underground or subsea cables, potentially causing corrosion to nearby pipes and affecting sea creatures in the latter case [70]. When used, the metallic return link is rated for full current, but with low voltage insulation requirements.

Figure 31 (a) illustrates both conventional HVDC monopole connection options, which are applicable to both LCC and VSC configurations, but more commonly used with LCC. Another monopole configuration that equally shares the full rated HV between two positive and negative links connecting both stations is known as symmetrical monopole (e.g., 320 kV lines rather than single 640kV line to ground) [68]. The direct advantage in symmetrical monopole systems is the decreasing of the voltage rating of the links, which is especially important in underground/subsea cable transmission. Figure 31 (b) illustrates the symmetrical monopole configuration, where midpoint grounds are defined at both converter stations. This configuration is common for offshore VSC applications. On the other hand, it is rarely implemented in case of LCC [71]. The main disadvantage of the discussed monopole configurations remains in that there is no inherent redundancy in the design, meaning that when there is a fault in one of the lines or converters, then the full transmission capacity is lost [72]. To overcome this issue, the bipolar configuration can be adopted as it provides increased reliability.

Figure 31: Common HVDC transmission configurations: (a) Monopole with both metallic and earth electrode return options. (b) Symmetrical monopole. (c) Bipolar system with both return options. Two return options are presented in (a) and (c) for illustration, real implementations use only one [65].

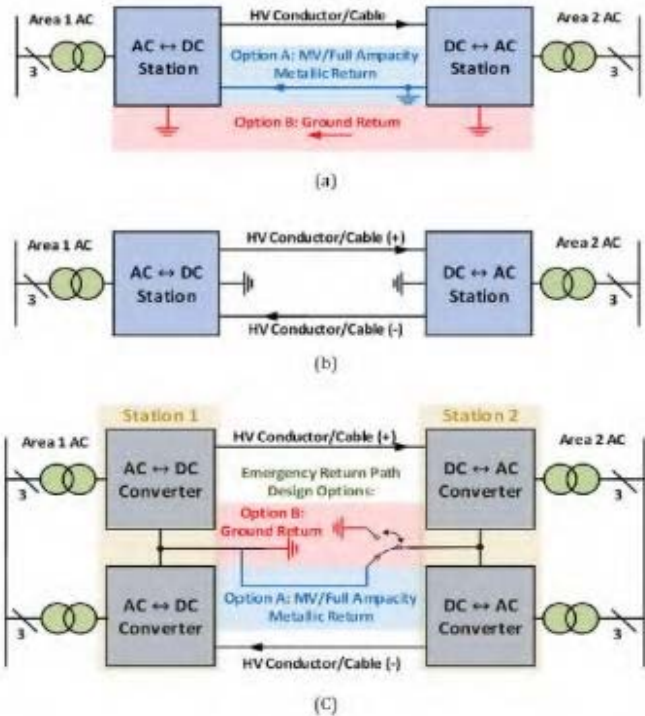
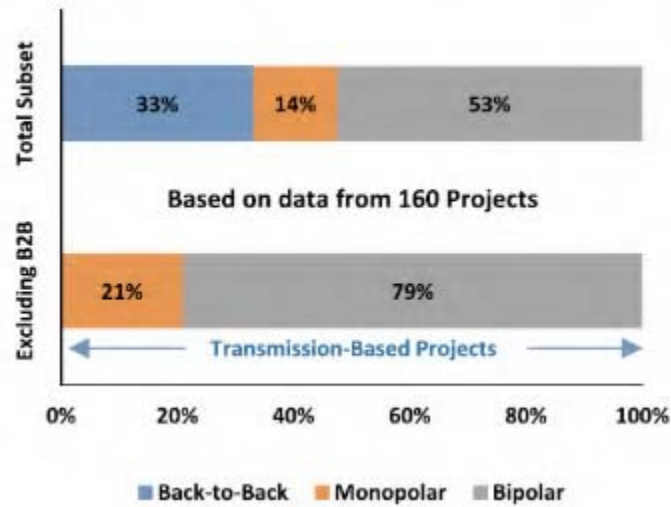

Figure 31 (c) illustrates a high-level block diagram of bipolar configuration alternatives, where in each station two converters grounded at midpoint are installed. These converters produce equal and opposite HV DC outputs, creating a normal energy flow path in the outer loop with negligible flow in the neutral/earth connection. The mid-point emergency return path can be designed using either earth electrodes or metallic return link, similarly to the monopole case. The main advantage of common bipolar configurations is the increased reliability, which is similar to that of a double-circuit AC transmission line. That is, a fault on any single transmission line/cable or converter pole results only in that link to independently shut down. In this scenario, provided that the fault does not affect other pole assets, the neutral link can be used as a low voltage return path, allowing for continued operation up to 50 % of the total HVDC power capacity [73][74][75]. As reported in Figure 32, 53 % out of 160 projects analysed by the Bloomberg New Energy Finance utilize bipolar links, 79 % not considering Back-to-Back projects [76].

Figure 32: Market share of the main HVDC configurations, including and excluding Back-to-Back links, based on data from 160 projects [76].



4.3 Line Commutated Converters (LCC)

Line-Commutated Converter (LCC) HVDC is a mature technology with the highest power and efficiency rating used for more than 50 years for bulk power transfer. LCC-HVDC technical capabilities, combined with its economic advantages and low operating losses, make it a widely used solution for empowering or enhancing power system interconnections [77][78]. LCC-HVDC technology employs line-commutated thyristor valve converters. Early LCC systems employed mercury-arc valves, however many adaptations were necessary to make them suitable for HVDC. Nowadays mercury-arc valves have been replaced by thyristors. A thyristor is a controllable semiconductor able to carry very high currents (4000 A) and to block very high voltages (up to 10 kV). Many thyristors connected in series build a thyristor valve, suitable to operate at hundreds of kV at the network frequency (50 Hz in Europe). A LCC requires a stable AC system voltage (high short-circuit power) for a reliable commutation so that the difference in reactive power must be kept within defined values to maintain the AC voltage in the desired tolerance [79]; in some cases, synchronous capacitors and flywheels are used to fulfil this requirement. This limitation is overcome in VSC stations. Figure 33 shows the configuration of a LCC-HVDC system.

Figure 33: LCC-HVDC converter station [61]

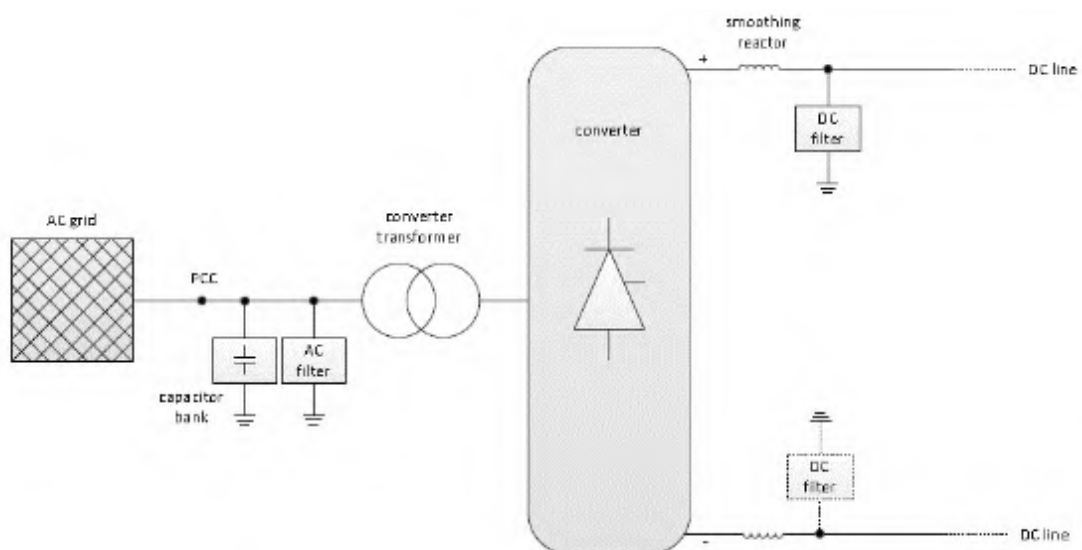

The function of LCC-HVDC components are as follows:

- *Converters:* DC/AC and AC/DC conversion is performed in the rectifier and inverter units. Each unit typically has a 12-pulse arrangement consisting of two 6-pulse thyristor bridges connected in series on the DC side.
- *Converter transformers:* Transformers, with tap changers to adjust the supplied AC voltage to the valve bridges, ensure optimisation of HVDC operation and are designed to work with high harmonic currents and to withstand AC/DC voltage stresses. The transformer for a 12-pulse bridge has a star-star-delta three-winding configuration and typically has a leakage reactance to limit the current during a short-circuit fault of the bridge arm.
- *AC and DC side filters:* Converter operation generates harmonic currents and voltages on the AC and DC sides, respectively. Common issues with high harmonics include machine heating, insulation stress, overloading of capacitor banks and interference with communication equipment. Some HVDC designs with overhead lines also implement a DC filter. DC filters are not required in cable transmission or back-to-back schemes.
- *Reactive power compensation:* A LCC-HVDC link has a high reactive power demand that varies with its loading. Typically, a large percentage of reactive power compensation is required, up to 60 % of the DC power rating, and is provided by filter banks and switchable capacitor banks or FACTS-based devices such as a STATCOM or SVC. If the converter unit is in a weak AC grid, it may be necessary to install synchronous condensers to increase the short-circuit level and improve the voltage control.
- *Control system:* The rectifier and inverter include various hierarchical control systems.
- *Smoothing reactors:* The DC side of the converter consists of smoothing reactors, which are primarily required to reduce harmonics on the DC side, prevent commutation failures and protect valves after DC faults [78].
- *DC connections:* Cables or overhead lines are always present on the pole connections, except in back-to-back systems. DC faults can be managed with LCC-HVDC technologies by controlling the short-circuit current, whereas in VSC-HVDC systems DC short-circuits could be more critical.

Losses in a single converter station can be assumed, for LCC technology, about 0.7 % of the power through the station. Of course, Joule losses on DC conductors should be added.

4.4 Voltage Source Converters (VSC)

Voltage Source Converter (VSC) technology was employed for the first time in 1997 in the Hellsjön project in Sweden [80]. Since then, a considerable development of this technology has been achieved: the first VSC-HVDC system was commissioned with a voltage of ± 10 kV and a transmission capacity of 3 MW; today VSC-HVDC systems with voltages above ± 500 kV and 2 GW are feasible. The INELFE VSC-HVDC system between France and Spain with a voltage of ± 320 kV and a DC power of 2x1 GW is at present the VSC system with the highest transmission capability [81]. The newest generation applies a modular concept (Modular Multilevel Converter, MMC) with an arbitrary number of voltage levels (dependent on the manufacturer), which leads to reduced losses and improved harmonic behaviour.

VSC uses Insulated Gate Bipolar Transistors (IGBTs) which can be both turned on and off. The turn-on and -off capabilities of IGBTs enable voltage generation on the AC side with a specific amplitude and phase angle. On the other side, as mentioned, thyristors can only be turned on, and this is why synchronous machines must be available in the AC system to which the LCC-HVDC is connected, in order to provide the commutating voltage. This makes VSC more flexible than LCC, as the VSC valves are independent on the operation of the AC grid. Hence, a VSC-HVDC system can be operated in weaker, and even in passive, AC systems (providing, e.g., black start capability). Furthermore, VSC can control the power flow and provide dynamic voltage regulation to the AC system [79][82][83]. Additionally, no reactive power compensation and less harmonic filtering are needed which results in more compact converter stations, making the use of VSC-HVDC advantageous for instance on

offshore platforms, where space saving is an important issue. Lastly, in LCC stations the direction of power flow can be changed only by reversing the polarity of DC voltage at both stations. In VSC it can be achieved by reversing the current direction, keeping the polarity of DC voltage constant. By this means, VSC can be easily connected to Multi-terminal HVDC systems [84].

Figure 34 shows the configuration of a VSC-HVDC system. The function of VSC-HVDC components are as follows:

- *Converter*: A VSC-HVDC system (point-to-point connection) consists of two converters (rectifier and inverter) at both ends in monopolar or bipolar configuration. The modular concept – with many series of connected submodules (half-bridge or full-bridge modules) in each arm – enables generation of an almost perfect sinusoidal voltage on the AC side of the converter.
- *Converter transformer*: Conventional two- or three-winding transformers are applied in VSC-HVDC systems to adapt the AC system voltage to an appropriate level for the operation of the converter. Tap-changers could be used in addition to the reactive power control of the converter to support voltage control.
- *Arm inductance*: The arm inductance determines the active and reactive power exchange between the AC system and the converter. Additionally, the inductances keep the loop currents between the parallel converter legs to a low level.
- *AC and DC side filters*: Generally, AC and DC filters can be omitted, as the voltage of the converter is almost perfectly sinusoidal and therefore the harmonic content is very low. In special cases, such as the application to overhead lines, DC filters are installed if required.
- *Control system*: The active and reactive power exchange is controlled by an outer and inner control loop. The outer loop calculates the reference values for the inner loop, which determines subsequently the firing pulses for the IGBTs.
- *DC capacitors*: The large DC capacitors of two- or three-level converters are – in cases of modular multilevel converters – distributed in the submodules along the converter arms.

Figure 34: VSC-HVDC converter station with modular multilevel converter:
1) half-bridge submodule, 2) full-bridge submodule [61]

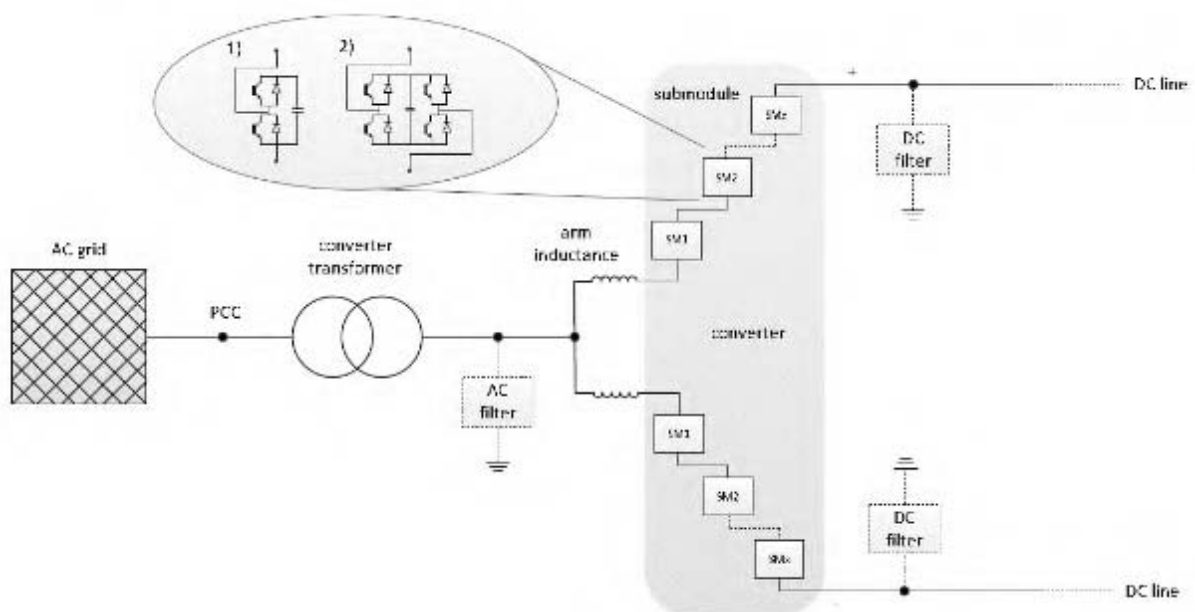

In the first VSC applications, losses in a single converter station were equal to 3 %. Afterwards, improvements accomplished have reduced losses up to 1.7 %. In the last years, a percentage of 1 % has been achieved [85]. Of course, Joule losses on conductors should be added. Despite the fact of being an emerging technology, VSC is facing a fast development. It is thus expected to become equivalent to LCC in terms of power capabilities and voltage levels. It is hence clear that VSC-HVDC represents a promising technology for the development of future HVDC grids.

4.5 Technical-economic HVAC vs. HVDC comparison

As already mentioned, the use of HVDC transmission over long distances provides several technical advantages when compared to HVAC [65]. In 2018 the maximum implemented distance for HVDC was the Changji-Guquan link in China which exceeds 3000 km [85]. In China was also the longest HVAC, the 1049 km Yuheng-Weifang link [87][88]. All overhead HVDC systems are characterized by very long length, and this can be explained as follows.

Considering the economic efficiency of the transmission lines alone (i.e., not including converter stations), DC transmission costs are significantly lower than AC three-phase transmission on equal power transferred. This statement is however limited to DC transmission losses and neglects the need for expensive AC line-reactive compensators [89]. HVDC also requires fewer cables/conductors and utilizes the full transmission capacity up to their thermal limits. This reduces the required cross-section for DC conductors and consequently the transmission cost [90]. As shown in Figure 35, a rough technical economic comparison shows that, neglecting costs and losses associated to the conversion, 1-wire DC transmission is always more economically efficient than 3-phase AC transmission (although it is not used due to reliability concerns), and that 2-wire DC transmission is more efficient than 3-phase AC transmission for AC power factors lower than 0.86 (in transmission systems, however, TSOs try to operate links at power factors higher than 0.86).

Figure 35. HVAC Vs HVDC line costs.

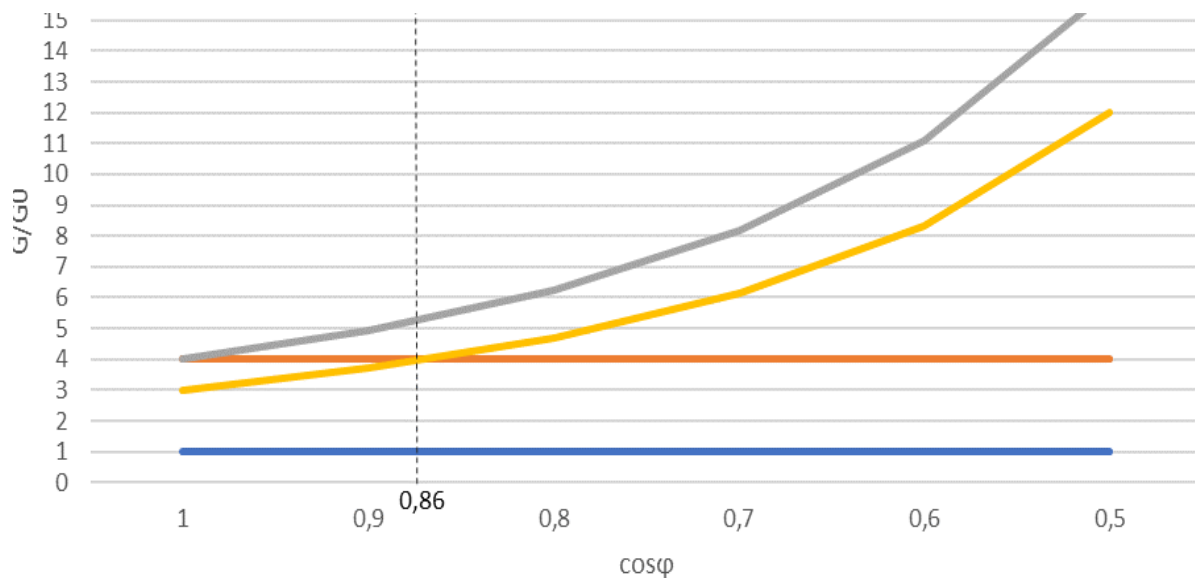

Right-of-Way (ROW) space (i.e., the required horizontal ground clearance distance) for DC transmission is also considerably lower compared to the AC equivalent, for both overhead and underground bulk power transmission options [91]. On the other hand, the expensive rectifier and inverter stations for AC/DC and DC/AC conversion, which are not required in HVAC case, significantly increase the overall HVDC transmission cost, thus offsetting efficiency benefits, depending on the distance.

Therefore, there is a HVDC breakeven distance, above which DC transmission becomes economically preferable than AC transmission: typical range is between ~300 km and ~800 km for overhead lines and ~50 km to ~100 km for offshore/underground cable links [89][90][73][92]. This variability is related to individual project conditions (e.g., MW/kV rating, transmission terrain and local policies). Figure 36 qualitatively summarizes the cost evolution of HVAC vs. HVDC with distance, indicating breakeven points, where it is also worth noticing that conversion losses at DC substations are not negligible for the overall transmission efficiency (notice that rated voltages are different, and so figures are not directly comparable). Figure 37 provides a comparison of the costs of different transmission alternatives for a 6000 MW/2000 km link [90].

Figure 36: qualitative breakeven distance assessment [91].

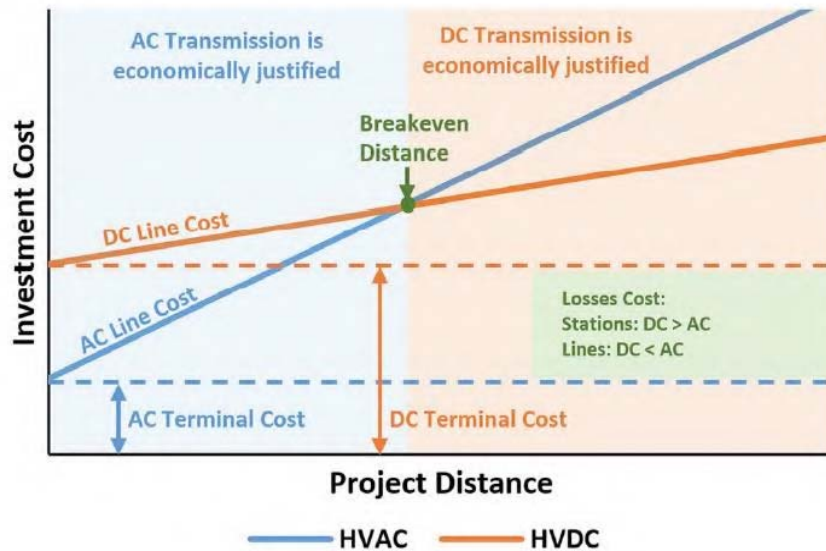
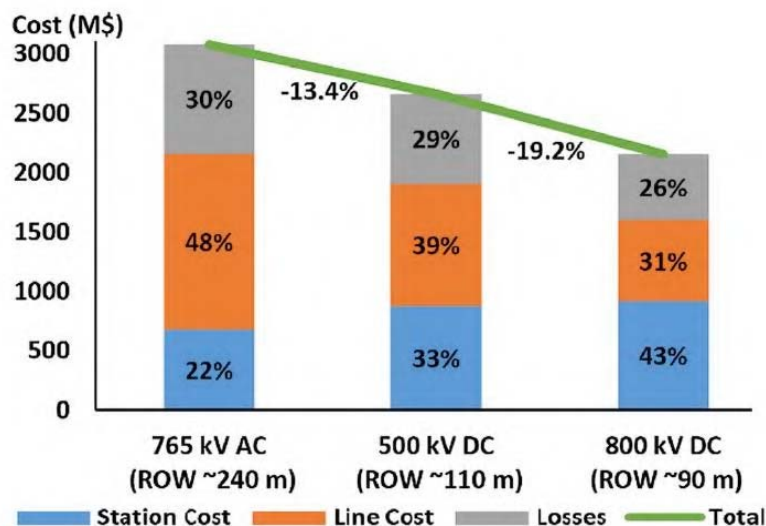

Figure 37: Cost and ROW estimation for a generic 6000 MW, 2000 km overhead transmission [91].



From a purely technical point of view instead, the primary advantages of HVDC links over HVAC links are [73][93]:

- The elimination of reactive power for power transmission purposes. Power can be transferred over long distances with constant voltage at the receiving end and therefore can enable full utilisation of the

conductors for real power transmission. AC reactive compensation becomes intractable in case of long AC cables, due to the reactive power produced by the cable, that makes it necessary to compensate that power in intermediate points of the line (and that is almost impossible in case of subsea transmission).

- Higher power transfer with the same size and insulation level of DC lines compared to AC lines. The effective voltage can be higher, and the wire cross-section can be larger (it is limited for AC lines due to the skin effect whereas a DC line can, in principle, accommodate any cross section). This also allows some savings in terms of ROW and towers.
- Lower losses on DC lines; however, for total loss calculation, HVDC converter stations should be added.
- HVDC links allow the connection of substations of asynchronous AC grids; they then can be used for market purposes as well as for system support by means of ancillary services.
- System operators can control the power flow in HVDC and this makes it possible also to control power flow in the AC transmission system as well. This may be challenging from an operational point of view; however, an adequate complementary control system can be used along with the HVDC lines in a coordinated manner to support system operation, for example, by reducing the number of required remedial actions for assuring system security as well as by improving transient stability and damping oscillations in the power system. This in turn will allow the system operator to utilize the existing AC network more efficiently. In other words, HVDC would increase significantly the flexibility of the whole power system, making it possible to accommodate larger amounts of renewable non dispatchable generation.

On the other hand, the primary disadvantages of HVDC links over HVAC links are:

- Voltage transformation (through power electronics) and DC circuit breakers are two weak points, from both the technical and the economic point of view, and still need improvements.
- The need for AC/DC and DC/AC conversion at the terminals of the DC transmission line offsets the advantages of DC links, independent of the transmission distance.

4.6 Conclusions on power losses in HVAC and HVDC Transmission Systems

In power systems, a substantial amount of power is lost on transmission and distribution, especially when the power is delivered over long distance [94] or at low voltages.

The phenomenon of Joule losses on conductors depends on the voltage: increasing voltage, at equal power transferred, current decrease linearly and losses, that depend on the squared current, decrease quadratically with voltage. This means that doubling transmission voltage allows reducing losses to $\frac{1}{4}$. This is true for both AC and DC, and this is why long-distance transmission is always carried out at high voltage, both in AC and DC. Voltages, however, cannot be increased boundlessly: increasing voltages results in increased clearances, cost of towers, cost of insulation and related devices, etc. This is why rated voltages of electrical lines are actually proportional to distances: for low distances it is not worth adopting high voltages, while for long distances, High Voltages (HV) or Extremely High Voltages (EHV) are used. In Europe, the transmission system is rated 400 kV, and there are a few lines with rated voltage higher (a couple of 750 kV lines, 4-500 km long, connecting the former Soviet Union system (CIS), in particular Ukraine, to Poland, Hungary and Romania systems). Actually, distances in the European grid do not justify the cost for higher rated voltages, while they are adopted in some cases when distances are longer, in Countries like Canada, USA, Russia, China (usually, max 800 kV).

Specifically, for losses in conductors, a comparison can be carried out between AC and DC transmission, under the following assumptions: the two systems will have the same requirements for voltage insulation to the ground, the conductors will have the same current density, the real power transferred is the same. Under such assumptions, losses on the DC system are 40 % -70 % of losses on the AC system, depending on the power factor on the AC system (in the following, let us assume 50 % for the sake of simplicity). However, it is necessary to sum, for HVDC, losses on converter stations that range from 1.4 % to 2 % of the transferred power.

As reported in [95] ENTOSE-E estimates that the AC EHV and HV transmission network losses in 2018 were 1.77 % of total consumption (on 400 kV grids); the International Electrotechnical Commission estimates about 2.5 % of energy lost in transmission systems [96]. Let us assume for the sake of simplicity a value of 2 %, the comparison is shown in **Table 4**. Similar conclusions are derived in [97][98][99]. Appendix IV gives out further information on converter station power losses.

Table 4 Sample of loss comparison for HVAC and HVDC Transmission systems.

Technology	Losses on conductors	Losses on Converter stations	Total losses
HVAC	2%	---	2%
HVDC-LCC	1%	1.4%	2.4%
HVDC-VSC	1%	2.0%	3%

It is worth noticing that HVDC systems are adopted in practice and are more economically efficient than HVAC systems in the following conditions:

- transmission over about 800 km for overhead lines (in such cases, AC transmission would be either impossible or very expensive for technical reasons);
- transmission over about 100 km for cables, especially undersea cables, for example to connect offshore wind farms (in such cases, AC transmission would be either impossible or very expensive for technical reasons);
- connection of two electric systems with different frequency;
- connection of a weak power systems to a very strong power system;
- need to accurately control real power flows between either two power system areas or two or more corridors;
- Frequency control reserve;
- Electricity market issues;
- Management of emergency conditions.